



# ELECTRIC WIRE ROPE HOIST



**DRH SERIES**

---

# TOP QUALITY PRODUCTS FROM A LEADING COMPANY

**Donati Sollevamenti offers a product in line with the most international standards.**

Donati Sollevamenti was founded in Italy in 1930 and has since then earned a leading position on the international market for lifting and handling equipment, with exports accounting for around two thirds of its total turnover.

The advanced design and construction features of all Donati products, are the basis for the competitiveness and reliability of the entire range, which is suitable for all industries.

Donati designs and manufactures its products in Italy, its marketing mix is known for its vast range (standard and special solutions), excellent quality/price ratio, fast response and delivery; it is the ideal partner for overhead travelling crane

manufacturers, material handling integrators and distributors as well as service companies specialised in retrofitting/ refurbishing. Donati is known in the market for its constant focus on customer satisfaction, its in-house priorities are the quality of processes, health and safety as well as environment protection (Donati is ISO 9001 - ISO 14001 - OHSAS 18001 certified).

Donati also complies with the provisions of the Italian Legislative Decree 231/01 concerning the administrative responsibility of legal entities and companies (governing Compliance, and also Safety and Environmental issues).

## THE DONATI LIFTING RANGE

The product range covers all aspects of Industrial lifting always offering an unbeatable value for money combined with a pleasing and professional design.

DMK electric chain hoists for capacities up to 4,000 kg, jib cranes with manual or electric rotation, DRH electric wire rope hoists with capacities up to 50,000 kg, DSC suspended modular systems and the DGP drive units, are all a safe, reasonably-priced choice for every situation. The special versions of each product, and on request, CSA homologation for DMK and DRH hoists, complete the range

ensuring an answer to the most diverse and specific application needs.

Donati Sollevamenti S.r.l.'s constant attention is always focused on maximum Customer satisfaction and is aimed at starting a long-term relationship based on mutual esteem and trust thanks to the flexibility and promptness of its organisation and direct personal contact.

The after sales service aims to resolve problems immediately, whether for spare parts, assistance or warranties.

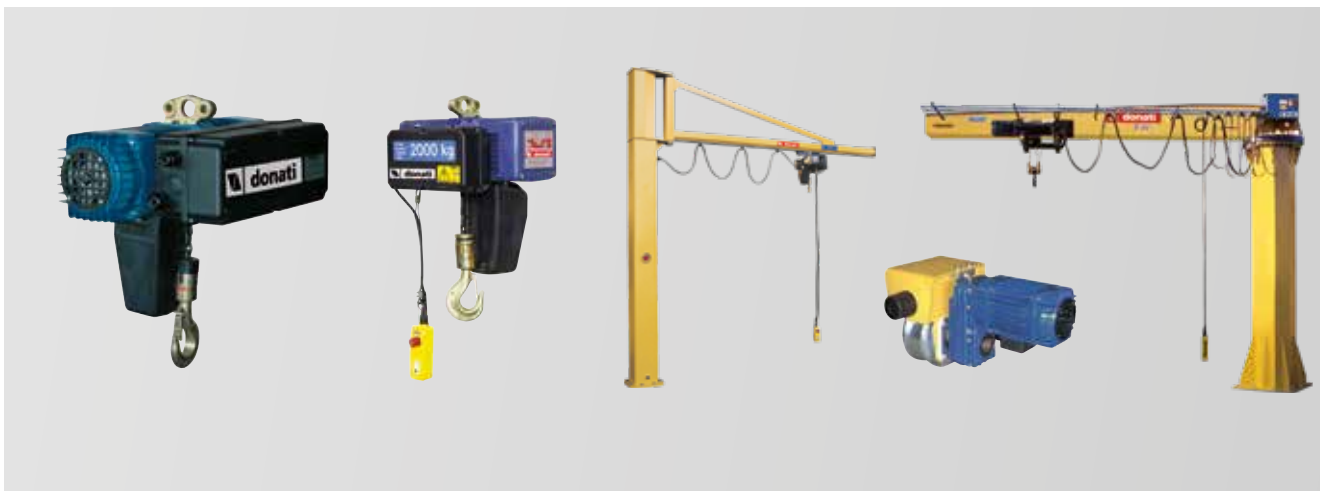

# ELECTRIC WIRE ROPE HOIST

**DRH SERIES THE MOST RELIABLE AND SAFE WAY OF LIFTING**



It guarantees maximum safety in hoisting up to 50,000 kg. The skill and experience in design and production, the quality of components used, the high technology employed in machining mechanical parts, in the finish and surface treatments as well as the EN ISO 9001: 2008 certified quality system which covers all of the company's activities, allow DONATI SOLLEVAMENTI to offer a product in line with the most modern international regulatory standards. The DRH electric wire rope hoist ensure wide range of uses, reliability over time and safety in all operating phases. The special water-repellent paintwork, applied with a completely enclosed electrostatic process, guarantees durability and constant top performance. The company offers a 3-year warranty starting from the date of delivery, all with excellent value for money.

---

## ELECTRIC WIRE ROPE HOISTS POWERFUL AND SAFE TROLLEYS AT YOUR SERVICE

The hoist combined with a trolley which runs on one or two beams also allows horizontal movements. All lifting (raise and lower) and traverse (right and left) movements are activated by a pushbutton panel or radio-control system.

The electric wire rope hoist and trolleys can be mounted overhead and fitted with monorails or act as the lifting unit for other machines, including: cranes (bridge, gantry, job, etc.) monorail and double girder.





The DRH series electric wire rope hoists and relative electric trolleys are made with modular components. This allows multiple standardised or special executions to be made quickly and inexpensively, and most importantly, safely. To guarantee maximum use of the hook run and minimum overall lateral dimensions of the hoist body, the basic components, (motor, gearbox and drum) are assembled in a coaxial line, with high strength bolted connections. Each connection can be inspected and has self-locking safety nuts.

The drum on the side opposite the gear motor can be connected (upon request) to a cycle counter, selectors, limits switches, encoders, etc. In addition, since it is perfectly symmetrical in the special execution with right and left threading, two gear motors can be installed doubling the lifting speed but maintaining the same capacity and vertical lifting axis. This solution is particularly suited for configurations with large hook runs.

The construction uses the most advanced technology and highly industrialised manufacturing processes to build totally reliable machines with economies of scale.

## THE DRH SERIES ELECTRIC WIRE ROPE HOIST RANGE IS CREATED IN:

### 4 BASIC SIZES

DRH 1-2-3-4, for capacities from 800 to 50,000 kg, in the FEM (ISO) service groups 1Bm (M3) -1Am (M4) - 2m (M5) - 3m (M6).

**ONE LIFTING SPEED** created with a 4 pole motor:

- 8 or 12 m/min. for 2 falls wire rope hoists
- 4 or 6 m/min. for 4 falls wire rope hoists
- 2.7 or 4 m/min. for 6 falls wire rope hoists
- 2 or 3 m/min. for 8 falls wire rope hoists

### TWO LIFTING SPEEDS

1/3 ratio created with a 4/12 pole motor:

- 8/2.6 or 12/4 m/min. for 2 falls wire rope hoists
- 4/1.3 or 6/2 m/min. for 4 falls wire rope hoists
- 2.7/0.9 or 4/1.3 m/min. for 6 falls wire rope hoists
- 2/0.7 or 3/1 m/min. for 8 falls wire rope hoists

**5 STANDARD VERSIONS** with: short (C), normal (N), long (L) or extra long (X1) and (X2) drum lengths, for hook runs from 4 to 58 m.



#### **IN FIXED EXECUTION**

This is the universal, basic configuration, with fixing eyebolts that allow any version of DRH hoist fixing on a frame or to be adapted in a suspended execution.

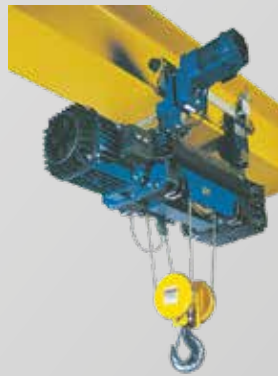

#### **ELECTRIC MONORAIL TROLLEYS, TYPE DST/N/S**

The DRH hoist is supplied in suspended execution with the normal trolley or articulated trolley for curved beams, it runs on a single beam and is operated electrically.

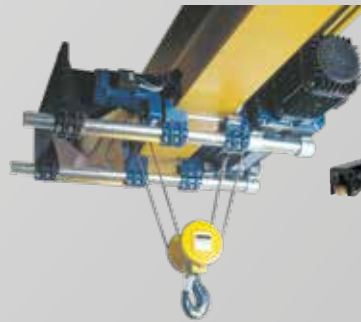

#### **ELECTRIC MONORAIL TROLLEY, TYPE DST/R**

In this configuration the DRH hoist is supplied in low headroom execution for maximum height of lift. It is compact and runs on a single beam; it is operated electrically.



#### **DOUBLE GIRDER TROLLEY, TYPE DRT**

The DRH hoist can be fitted longitudinally on the frame or suspended, or in transversal execution, on the trolley, which runs on two beams and is operated electrically. The two girder trolley execution allows the maximum hook run of the hoist.

### **PROTECTION AND INSULATION OF ELECTRICAL PARTS**

- Hoist and trolley motors: IP55 protection – “F” insulation class
- Motor brake IP23
- Limit switch: IP65 minimum protection - Maximum insulation voltage 500 V
- Cables: IEC 20/22 II Maximum insulation voltage 450/750 V.

### **ELECTRICAL POWER SUPPLY**

- DRH electric rope hoists are designed to be supplied with AC electrical current with three phase voltage: 400 V - 50Hz in accordance with IEC 38-1.
- Non-standard voltages and frequencies are available upon request.

### **NOMINAL WORKING CONDITIONS**

- Operating temperature: minimum -10°C; maximum +40°C
- Maximum relative humidity: 80%
- Maximum altitude 1000 m above sea level
- The hoist must be installed in a well ventilated ambient, free from corrosive fumes (acidic fumes, saline mist, etc.).

### **NOISE LEVEL**

- The sound pressure level emitted by the hoist when fully loaded is always less than 80 dB (A). The incidence of environmental characteristics such as the transmission of sound through metallic structures, reflection caused by combined machines and walls, is not included in the indicated level.

# THE HOIST IN DETAIL

## DESIGN AND CONSTRUCTION

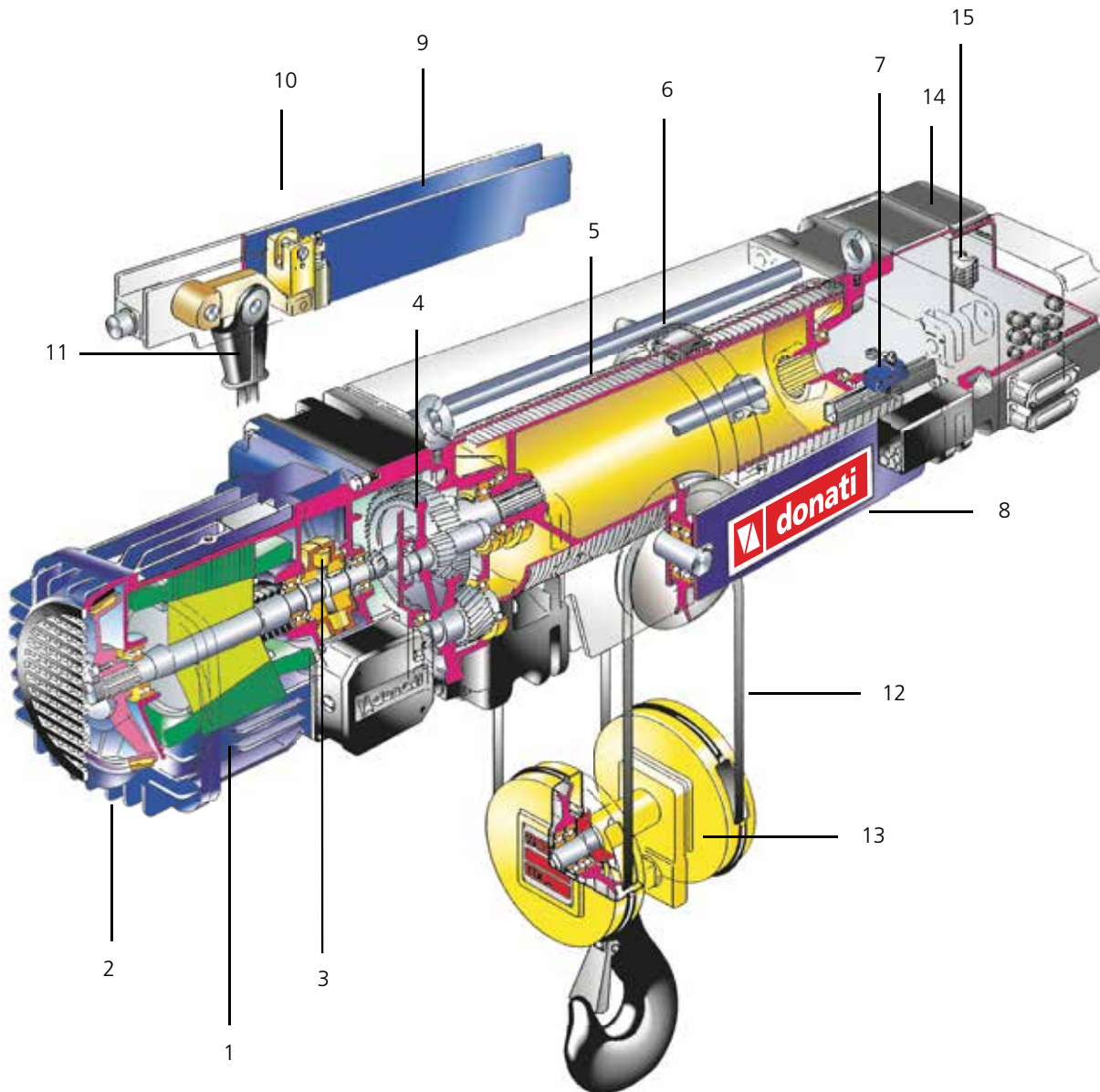

### 1. ELECTRIC MOTOR FOR LIFTING

- Asynchronous, three-phase, self-braking with tapered motor. Minimum protection IP 55 – Class F insulation. It has thermal probes for protection against overloading.
- DRH4 motor, 24 kW cylindrical, asynchronous and three phase.

### 2. LIFTING BRAKE

- The conical brake is fitted with asbestos free lining. The brake block, which has a fan that guarantees cooling of the brake and the motor, moves axially with the motor shaft and the braking function is activated automatically if the energy supply fails. [RES. 1.2.3 – 4.1.1.6 c) - Annex I Machinery Directive].
- DRH4 24 kW electromechanical brake.

### 3. COUPLING

This creates the connection between the self-braking motor and the gearbox, allowing perfect axial sliding of the motor shaft.

### 4. GEARBOX

Coaxial, with three stages of reduction, with cylindrical gears made of thermally treated, highly resistant steel, helical

teeth. Dimensioned and made to withstand the phenomena of stress and wear for life in relation to the normal FEM service group. [RES. 4.1.2.3 - Annex I Machinery Directive]. The whole machine is mounted on ball bearings lubricated for life in an oil bath.

#### **5. DRUM**

The drum in steel casing, is mechanically grooved and supported by the flange of the gearbox and the equipment side flange, with hubs with rotating broached holes on permanently lubricated bearings. The drum is dimensioned based on the standards ISO 4308-1:2003 and UNI 9466:1994 as well as the FEM rules 9.661/86. The drum support flanges are fitted with steel cylindrical pins to secure the components which suspend and support the hoist. Mechanically machined seats support the anchorage crossheads and the return pulley. The connection between the two casings is made with bolted stay bolts.

#### **6. ROPE GUIDE**

This has a threaded ring made of spheroidal cast iron and allows excellent winding of the rope on the drum. [RES. 4.1.2.4 – Annex I Machinery Directive]. An elastic system automatically registers any play or wear. The rope guide is equipped with sliding backlash arms made of brass, which, by acting on the hoist stay bolts, function as raise and lower limit switches.

#### **7. LIFTING LIMIT SWITCH**

This is a safety component which limits the run of the hook, both raising and lowering, in an emergency. [RES. 4.1.2.6 a) - Annex I Machinery Directive]. It is composed of two precision microswitches which operate according to the "positive slow opening" principle and work on the auxiliary circuit of the hoist motor control device.

#### **8. PULLEY ASSEMBLY**

Used in versions with 4 rope falls, and supported by two pivots which allow it to be oriented based on the vertical axis of the rope. It is equipped with a return pulley made of carbon steel with mechanically grooved rim and turns on permanently lubricated ball bearings.

#### **9. ANCHORAGE CROSSHEAD**

Used in versions with 2 and 4 rope falls, and supported by two pivots which allow it to be oriented based on the vertical axis of the rope. The overload device is located between the plates of the beam.

#### **8A/9A PULLEY AND ANCHORAGE SUPPORT**

Used in the 6 and 8 rope fall versions, it is composed of an electric welded metal structure and is equipped with a connection plate to be positioned on the double girder trolley. It is fitted with return pulleys made on carbon steel with a mechanically grooved rim and turns on permanently lubricated ball bearings. The overload device is positioned between the support plates on the swinging beam.

#### **10. OVERLOAD DEVICE**

All DRH series electric rope hoists have an overload device with a threshold level microswitch. [RES. 4.2.1.4 - Annex I Machinery Directive]. The electromechanical overload device, constantly measures and checks the value of the load and the dynamic and inertial effects due to its movement. When the set values are exceeded the microswitch of the device starts by opening the control circuit of the hoist motor control device.

#### **11. WEDGE ANCHORAGE**

The anchorage is made of spheroidal cast iron. The minimum coefficient of utilisation is in compliance with the FEM rule 9.661/86. The rope is secured with a wedge which keeps it from unwinding.

#### **12. ROPE**

This is made of flexible steel, highly resistant to strain and wear. The minimum coefficient of utilisation has been selected to comply with the ISO standard 4308-1:2003. Non-twist ropes are used on DRH hoists with 2 falls and long (L) and extra long, 1<sup>st</sup> size (X1) drums, and on 2 and 4 fall hoists with extra long, 2<sup>nd</sup> size (X2) drums.

#### **13. HOOK BLOCK AND HOOK**

The return pulley is made of carbon steel with mechanically grooved rim. It rotates on bearing which are permanently lubricated. The load hook is made of highly resistant drop forged steel and is

mounted on a swinging cross beam.

It rotates on a thrust bearing and has a safety device to prevent unhooking. [RES. 4.1.2.6 - Annex I Machinery Directive].

#### **14. FRAME FOR ELECTRICAL CONNECTIONS**

Supplied upon request. It has cable intake and allows the wiring of all the connections of the electrical equipment of the hoist and electric travel trolley, if present. The compartment for the electrical connections and/or any other low voltage control equipment, is closed with a shock resistant thermoplastic cover, IP 55 protection.

#### **15. LOW VOLTAGE CONTROLS**

When the hoist is supplied complete with electric controls, the raise and lower and/or right and left functions of the trolley are activated by electrical equipment which includes:

- The transformer for the low voltage control circuits.
- The main contactor and contactors/reversing contactors for controlling the motors.
- The fuses for protecting the motors and transformer.
- The terminal board for connections of the auxiliary and power circuits.

The components are mounted on a hinged panel and fixed in a compartment located on the side opposite the motor. The controls are activated by a push-button panel supplied in AC at low voltage. The push-button panel is ergonomically shaped, watertight and made of self-extinguishing, shock resistant, thermoplastic material. Its protection level is IP 65. The emergency stop [RES. 1.2.4.3 - Annex I Machinery Directive], is activated by voluntarily pushing the mushroom shaped button, which starts the control circuit [RES. 1.2.3 - Annex I Machinery Directive]. The push-button panel is connected to the electrical equipment by a multipolar electrical cable with break-resistant metallic cores.

---

# TROLLEYS

DESIGN AND CONSTRUCTION

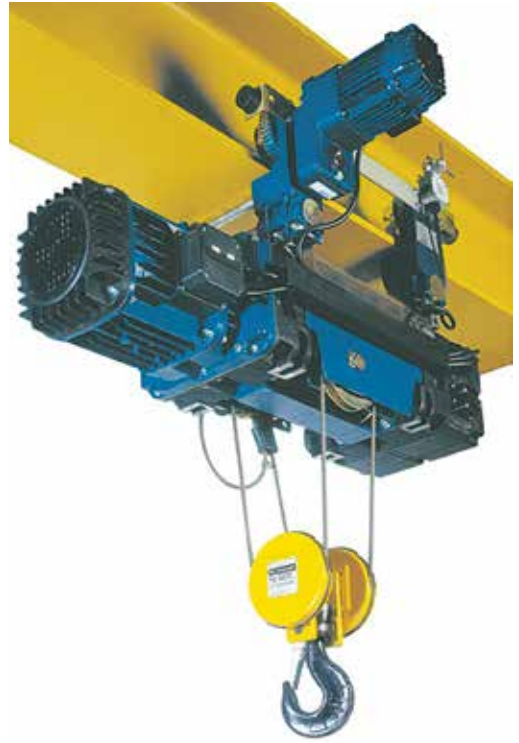
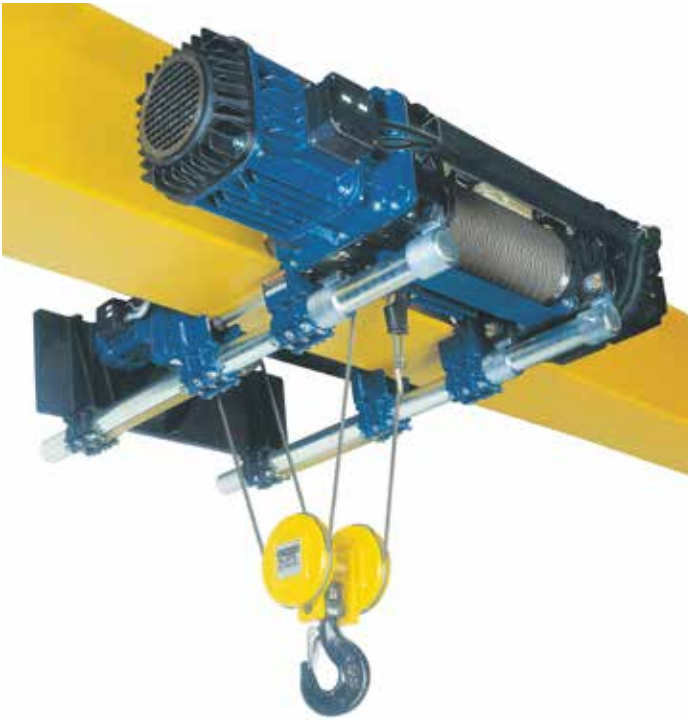



**MONORAIL ELECTRIC TROLLEY,  
TYPES DST/N - S - R  
NORMAL - ARTICULATED – LOW HEADROOM**

These are normally composed of an idler unit and drive unit, each equipped with two wheels made of mechanically machined pressed steel and mounted on permanently lubricated ball bearings. The wheels of the drive unit are opposing, have a crown gear wheel and are connected to each other by a transmission bar in the normal (N) and low headroom (R) versions. The articulated version (S), is equipped with a double gear motor, both of which directly give the wheels the movement. The steel supporting plates have anti-derailment and anti-drop systems [RES. 4.1.2.2 – Annex I Machinery Directive] and rubber buffers. Travel is assured by one or two self-braking motors with tapered motor, progressive start up and braking, one or two speeds and one of two offset gear motors with gears with helicoidal teeth which are permanently lubricated in an oil bath.

**ELECTRIC TROLLEY, NORMAL MONORAIL,  
TYPE DST/N**

In the normal version the trolley has supporting bars with circular cross-sections that support the hoist by hinge and pin suspensions. The drive and idler plates can be adjusted along the bars in relation to the width of the running beam and are complete with brackets fitted with bolted joints. Both units, drive and idler, are connected to each other with strengthening plates.

**ELECTRIC TROLLEY, MONORAIL,  
REDUCED HEADROOM, TYPE DST/R**

In the low headroom version the trolley has supporting bars with a circular cross-section that support the hoist in standing position. The drive and idler plates are sliding and can be adjusted along the bars in relation to the width of the running beam with brackets fitted with bolted joints. The trolley has a counterbalance on the supporting bar with circular cross-section to balance the eccentric weight of the hoist.

**ELECTRIC TROLLEY, MONORAIL,  
ARTICULATED, TYPE DST/S**

In the articulated version the trolley has supporting bars with cross-sections and brackets with hinged joints which support the hoist. The drive and idler plates are sliding and can be adjusted along the bars in relation to the width of the running beam and are fitted with bolted joints. Both drive units are opposing on the same bar and are independent from the idler units.

**ELECTRIC TROLLEY, DOUBLE GIRDER, TYPE DRT**

The wheels, two of which are driven and two idler, are supported by a steel frame. The wheels, pressed from carbon steel, rotate on permanently lubricated ball bearings. The double girder trolley is equipped with devices to avoid derailment and dropping [RES. 4.1.2.2 – Annex I Machinery Directive] and rubber buffers. Activation of the traverse is assured by a self-braking motor with tapered motor, progressive start up and braking, one or two speeds and an offset gear motor with gears with helicoidal teeth which permanently lubricated in an oil bath. They confer the movement to the drive wheels by a transmission bar. The hoist can be lifted on the top of the trolley or can be suspended or transversal.

**TRAVERSE LIMIT SWITCHES**

Upon request all trolleys can be supplied complete with limit switches [RES. 4.1.2.6 a) - Annex I Machinery Directive].

**TOWING ARM**

A towing arm is available upon request for all trolley types, adjustable in all directions, to connect the trolley/hoist to the electricity supply and prevent breakage of the conductors.

**OSCILLATING BRACKET FOR HOISTS  
MOUNTED ON A DST/N TROLLEY**

Available upon request to allow the hoist to oscillate in relation to the vertical axis of the running beam.





Deutsch English Français Italiano español

› Company › Products › Documentation › Safety Policy › Code of ethics › Privacy

## MANUAL AND ELECTRIC JIB CRANES

Made in Italy designed for the world



1 2 3 4 5 6 7 8 9 10 11 12 13 14 15 16 17 18 19 20 21 22 23 24 25 26 27 28 29 30 31 32 33 34 35 36 37 38 39 40 41 42 43 44 45 46 47 48 49 50 51 52 53 54 55 56 57 58 59 60 61 62 63 64 65 66 67 68 69 70 71 72 73 74 75 76 77 78 79 80 81 82 83 84 85 86 87 88 89 90 91 92 93 94 95 96 97 98 99 100

### DONATI SOLLEVAMENTI SRL



**Contacts in Italy** ›

**Contacts export** ›

**Donati Shop** ›

**Brochures & User Guides**

- › Electric chain hoist
- › electric wire rope hoist
- › Jjib cranes
- › Drive unit for cranes
- › Endcarriages for bridge cranes
- › Channel Profile

Documentation

### PHOTO GALLERY



#### Applications

› Open gallery

### DONATI NEWS

- › Il nuovo sito è Online!
- › The new website is coming
- › A new logo for Donati
- › Donati aderisce al Consorzio Qualità
- › Award EXPORT to Donati Sollevamenti

### LIFTING PRODUCTIVITY SINCE 1930



› Download the institutional Donati brochure

› Institutional Donati brochure

# PERFECTLY UP-TO-DATE

**ARIANNA: THE SOFTWARE THAT GUIDES MANUFACTURERS IN THEIR SELECTION OF COMPONENTS TO DESIGN BRIDGE CRANES.**

## MAIN FEATURES OF THE CRANE DESIGNER SOFTWARE

Guided selection of the Appropriate Donati products for manufacturing bridge cranes, based on the structural and mechanical requirements of the intended use and environment, by entering the following inputs:

- 1) Capacity – SPAN – FEM class and configuration (Single Girder – Double Girder)
- 2) Selection of hoist type
- 3) Selection of trolley type
- 4) Type of Beam material, desired deflection (from 1/600 to 1/1000)
- 5) Selection of the Electrical Control System.

Following outputs are therefore obtained:

- Beam type (Box Beam or HE Beam) with relative dimensions and static specifications
- Endcarriage type and Gear Motor type based on speed
- Layout diagram of the installation
- List of data and codes with relative prices
- Possibility of creating a quotation directly in a word format.
- Possibility of printing the crane layout.

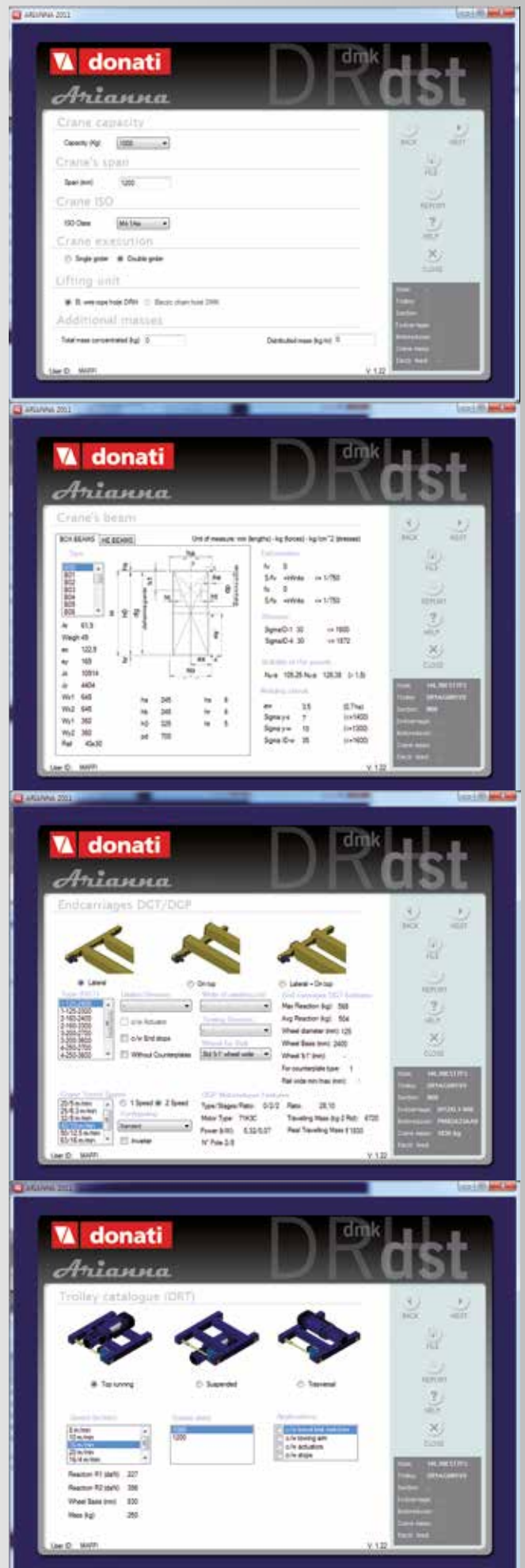
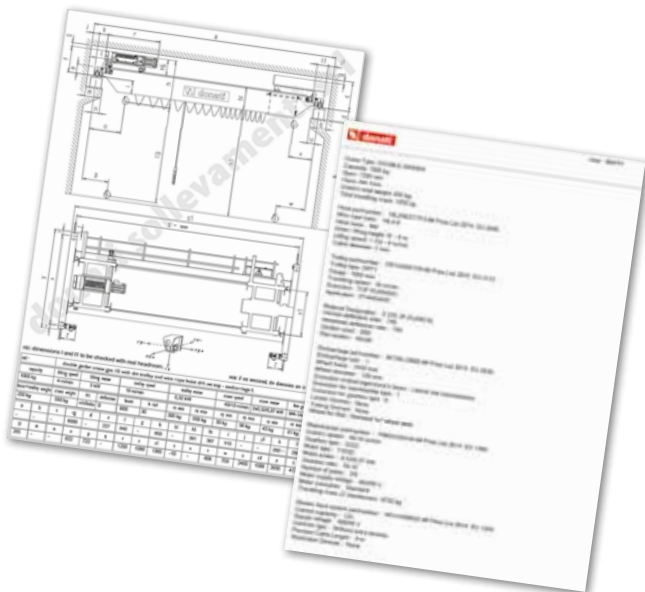

# STANDARDS AND CERTIFICATIONS

## DESIGN AND CONSTRUCTION

Donati Sollevamenti S.r.l.'s continuous focus on quality is not just seen in its careful designing, responsible choices and constant testing of materials, production phases and finished product. It involves the whole company through its quality assurance system which has been in place since 1993 and governs and controls the life of the entire company. The integrity in the design and production of all Donati products

The hoists and their trolleys are designed and manufactured taking into consideration the **“Essential Safety Requirements”** in **Annex I of the EU Machinery Directive 2006/42/EC** and are placed on the market and **EC Declaration of Conformity**, as per **Annex IIA of the same Directive**.

In addition, DRH series hoists and their trolleys comply with the following Directives:

- **LOW VOLTAGE DIRECTIVE 2014/35/UE**
- **ELECTROMAGNETIC COMPATIBILITY DIRECTIVE 2014/30/UE**

would not be complete without the careful consideration of the international regulatory framework and standards which are a guarantee of safety for the customer and user. In this light we recommend reading the CSA homologation of DRH rope hoists and relative accessories and trolleys built in a special execution for the North American market.

## REGULATORY REFERENCE FRAMEWORK

The design and construction of DRH series electric wire rope hoists the following technical standards and rules were taken into consideration:

- EN ISO 1210:2010 “Fundamental concepts, general design principles”
- EN ISO 13849-1:2008 “Safety-related parts of control systems”
- EN 12077-2:2008 “Limiting and indicating devices”
- EN 13001-1:2009 “General design – Part 1: General principles and requirements”
- EN 14492-2:2009 “Power driven winches and hoists – Part 2: Power driven hoists”
- EN 60204-32:2009 “Safety of the electrical equipment of lifting machines”
- EN 60529:1997 “IP enclosure (IP Codes)”
- ISO 4301-1:1988 “Classification of lifting equipment. General”
- ISO 4308-1:2003 “Selection of wire ropes – General”
- DIN 15401 “Choice of lifting hooks”
- UNI 9466:1994 “Shell drum. Design requirements”
- FEM 1.001/98 “Rules for the design of lifting equipment”
- FEM 9.511/86 “Mechanisms classification”
- FEM 9.661/86 “Dimensions and designs of rope reeving components”
- FEM 9.683/95 “Selection of lifting and traverse motors”
- FEM 9.755/93 “Periods of safe work”
- FEM 9.761/93 “Lifting force limiters”
- FEM 9.941/95 “Control symbols”



# OPERATING LIMITS, OPERATING CONDITIONS AND LIFE SPAN

Correctly determine the operating limits of the hoist in order to ensure correct operation and duration as well as complete compliance of the operating system with the work for which it is intended.

The ISO standard 4301-1:1988 and FEM rule 9.511/86 make it possible to classify electric rope hoists based on their use and the parameters necessary for determining the limits of use are the following:

## ACTUAL LIFTING CAPACITY

This is determined by the heaviest load to be lifted.

**! The nominal lifting capacity of the hoist must be  $\geq$  the actual lifting capacity. Lifting capacity = kg**

**THE STATE OF STRESS** is evaluated considering the average entity of the loads lifted and is ascribable to one of the four spectrums load shown below which determine the type of service.

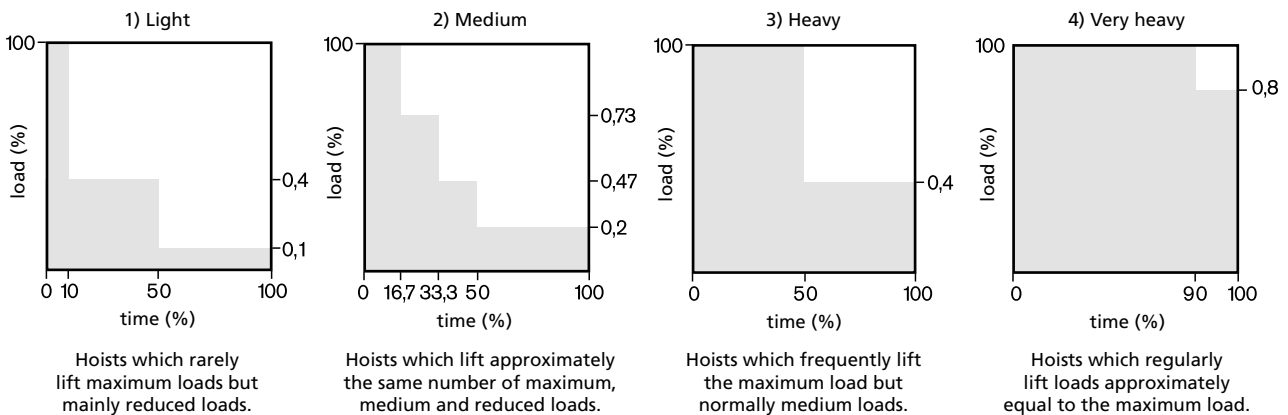

## AVERAGE DURATION OF DAILY OPERATION

For **LIFTING** operations the average duration of operation is calculated as follows:  **$T_m$  (hours) = (AHR x C/h x Rt) / (30 x S)**

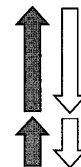
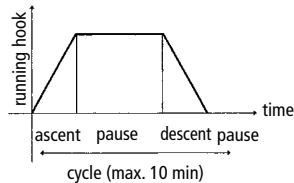
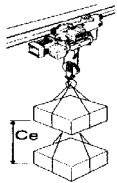

Actual hook run  
**AHR = m**

It is the average of the actual runs of the load

Cycles in an hour  
**C/h = N°**

It is the number of complete ascents and descents carried out in an hour.

Running time  
**RT = hours**

Hoist running time in a whole day.

Lifting speed  
**S = m/min**

It is the distance covered by the load in a minute.

For **TRAVEL** operations the average duration of operation is calculated as follows:  **$T_m$  (hours) = (Aar x C/h x Rt) / (30 x S)**

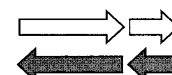
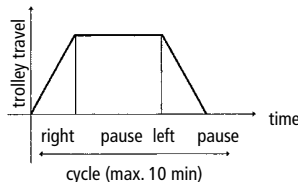
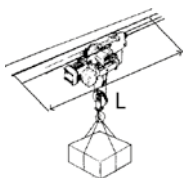

Actual average run  
**Aar (m) = L/2**

It is the average length L of the trolley running beam.

Cycles in an hour  
**C/h = N°**

It is the number of complete runs (right and left) carried out in an hour.

Running time  
**RT = hours**

It is the running time of the trolley in a day.

Travel speed  
**S = m/min**

It is the distance covered by the trolley in a minute of continuous running.

## SELECTION OF THE LIFTING EQUIPMENT

According to the type of use, that determines the **stress level** and calculation of **average daily use time**, for lifting and/or travelling, the following table can be used to classify the group and the related mechanisms and select the type of

hoist in relation to the **capacity**.

Once the type of hoist is identified, it is important to check the related life in terms of hours of service and total number of cycles in 10 years of operation.

### FOR EXAMPLE:

Capacity = 6300 kg  
 Level of stress = 2) Medium Load  
 Actual hook run = AHR 2.5 M  
 N° of cycles per hour = C/h 8  
 Daily running time = Rt 8 h  
 Lifting speed = S 4 m/min (4/1 rope falls)  
 N° of working days per year = D/y 220

### 1) Calculation of the average daily running time:

$$T_m \text{ (hours)} = (AHR \times C/h \times Rt) / (30 \times S) = (2.5 \times 8 \times 8) / (30 \times 4) = 1.33 \text{ h}$$

In the table on page 15, in relation to the Capacity (6300 kg), at the medium level of stress (2) and at the average duration of daily operation ( $T_m = 1.2$  h) it is possible to determine the rope hoist, with 4/1 rope falls, which is:

**Service Group FEM 1Am – Type DRH 24L1• M**

### 2) Test of life span: Hours of operation in 10 years

$$T_m \times D/y \times 10 \text{ years} = 1.33 \times 220 \times 10 = 2933 \text{ (hours)} < \text{of the 3200 (maximum hours possible)} \blacktriangleright \text{OK}$$

N° operating cycles in 10 years

$$C/h \times Rt \times D/y \times 10 \text{ years} = 8 \times 8 \times 220 \times 10 = 140800 \text{ (cycles)} < \text{of the 250000 (maximum cycles possible)} \blacktriangleright \text{OK}$$

## LIFE SPAN OF THE LIFTING EQUIPMENT

The overall life span of the lifting equipment is determined from the stress level, real hours of operation of each mechanism and the number of operating cycles of the complete machine. The operating hours and the number of cycles, which depends on the lifting equipment FEM/ISO service group classification, are conventionally expected to allow safe use for a period of 10 years.

Thus, after 10 years, the machine may have finished its expected life span, i.e. completed the available operating cycles, related to its specific service group. For this reason, when the 10th year has finished the lifting equipment SHOULD NOT be used unless it is inspected by DONATI SOLLEVAMENTI S.r.l. or by expert technicians

assigned for this purpose, aimed at checking if the equipment still has some remaining working life and is therefore able to operate safely for an additional period of time, or should undergo a general overhaul.

The classification of the hoist service group is shown on the machine plate affixed to it.

DONATI SOLLEVAMENTI S.r.l. guarantees the safe use of the DRH wire rope hoist for the entire duration of its expected lifespan, only if used in compliance with the parameters corresponding to the service group and subject to correct, regular maintenance.

### CLASSIFICATION AND LIMITS OF USE OF THE LIFTING EQUIPMENT ELECTROMECHANISMS

Use based on the stress level (type of duty)		Tm = Average duration of daily operation (hours)	≤ 2	≤ 4	≤ 8	≤ 16	> 16	> 16
			1) Light	Life span of the mechanisms in 10 years of operation (hours)	3200	6300	12500	25000
2) Medium	N° max of operating cycles in 10 years of operation (Σ cycles)	250x10 <sup>3</sup>	500x10 <sup>3</sup>	100x10 <sup>4</sup>	200x10 <sup>4</sup>	400x10 <sup>4</sup>	> 4x10 <sup>6</sup>	
	Tm = Average duration of daily operation (hours)	≤ 1	≤ 2	≤ 4	≤ 8	≤ 16	> 16	
	Life span of the mechanisms in 10 years of operation (hours)	1600	3200	6300	12500	25000	50000	
3) Heavy	N° max of operating cycles in 10 years of operation (Σ cycles)	125x10 <sup>3</sup>	250x10 <sup>3</sup>	500x10 <sup>3</sup>	100x10 <sup>4</sup>	200x10 <sup>4</sup>	400x10 <sup>4</sup>	
	Tm = Average duration of daily operation (hours)	≤ 0,5	≤ 1	≤ 2	≤ 4	≤ 8	≤ 16	
	Life span of the mechanisms in 10 years of operation (hours)	800	1600	3200	6300	12500	25000	
4) Heavy	N° max of operating cycles in 10 years of operation (Σ cycles)	63x10 <sup>3</sup>	125x10 <sup>3</sup>	250x10 <sup>3</sup>	500x10 <sup>3</sup>	100x10 <sup>4</sup>	200x10 <sup>4</sup>	
	Tm = Average duration of daily operation (hours)	≤ 0,25	≤ 0,5	≤ 1	≤ 2	≤ 4	≤ 8	
	Life span of the mechanisms in 10 years of operation (hours)	400	800	1600	3200	6300	12500	
<b>Service group of lifting and travelling mechanisms</b>	as per ISO standard 4301-1	<b>M3</b>	<b>M4</b>	<b>M5</b>	<b>M6</b>	<b>M7</b>	<b>M8</b>	
	as per FEM rule 9.511	<b>1Bm</b>	<b>1Am</b>	<b>2m</b>	<b>3m</b>	<b>4m</b>	<b>5m</b>	
Intermittent use as per FEM rule 9.683/95	Ratio of intermittence (RI%)	25	30	40	50	60	60	
	Maximum n° of start-ups per hour (A/h)	150	180	240	300	360	360	
	Maximum n° of cycles per hour (C/h)	25	30	40	50	60	60	
	Ratio of intermittence (RI%)	20	25	30	40	50	60	
	Maximum n° of start-ups per hour (A/h)	120	150	180	240	300	> 360	
Meccanismi del Carrello	Maximum n° of cycles per hour (C/h)	20	25	30	40	50	> 60	
	Operation time at main speed (min)	15	15	30	30	60	> 60	
Temporary use	Operation time at low speed (min)	2,5	3	3,5	4	5	6	
	Maximum n° of start-ups per hour (A/h)	10	10	10	10	10	10	
	Two speed double polarity motors	Max n° of start-ups per hour (A/h)	Main speed	1/3 (33,3% of the total n° of start-ups per hour)				
		Low speed	2/3 (66,7% of the total n° of start-ups per hour)					
Tm = Average duration of daily operation (hours)		Main speed	2/3 (66,7% of the average duration of daily operation)					
		Low speed	1/3 (33,3% of the average duration of daily operation)					

# IDENTIFICATION OF THE HOIST AND RELATIVE TROLLEYS

ROPE FALL CONFIGURATION → (SINGLE-GROOVED DRUM)			8 FALLS (8/1)			6 FALLS (6/1)		4 FALLS (4/1)				2 FALLS (2/1)		
CAPACITY kg	ABBREVIATION		DRH TYPE IN FEM GROUP (ISO)			DRH TYPE IN FEM GROUP (ISO)		DRH TYPE IN FEM GROUP (ISO)				DRH TYPE IN FEM GROUP (ISO)		
	GEAR BOX	CAPACITY	1Bm (M3)	1Am (M4)	2m (M5)	1Am (M4)	2m (M5)	1Bm (M3)	1Am (M4)	2m (M5)	3m (M6)	1Am (M4)	2m (M5)	3m (M6)
800	L	D												12L3•D
800	V	D												12V3•D
1000	L	E									14L3•E		12L2•E	12L3•E
1000	V	E									14V3•E		12V2•E	12V3•E
1250	L	F									14L3•F	12L1•F		12L3•F
1250	V	F									14V3•F	12V1•F	22V2•F	22V3•F
1600	L	G									14L3•G	12L1•G	12L2•G	22L3•G
1600	V	G									14V3•G		22V2•G	32V3•G
2000	L	H								14L2•H	14L3•H	12L1•H	22L2•H	22L3•H
2000	V	H								14V2•H	24V3•H	22V1•H	32V2•H	32V3•H
2500	L	I							14L1•I		14L3•I	22L1•I	22L2•I	32L3•I
2500	V	I							14V1•I	24V2•I	24V3•I		32V2•I	32V3•I
3200	L	J							14L1•J	14L2•J	24L3•J	22L1•J	32L2•J	32L3•J
3200	V	J						14V0•J		24V2•J	34V3•J		32V2•J	42V3•J
4000	L	K							14L1•K	24L2•K	24L3•K	32L1•K	32L2•K	32L3•K
4000	V	K							24V1•K	34V2•K	34V3•K	32V1•K	42V2•K	42V3•K
5000	L	L							24L1•L	24L2•L	34L3•L	32L1•L	32L2•L	42L3•L
5000	V	L						24V0•L		34V2•L	34V3•L		42V2•L	
6300	L	M							24L1•M	34L2•M	34L3•M	32L1•M	42L2•M	42L3•M
6300	V	M								34V2•M	44V3•M	42V1•M		
8000	L	N							34L1•N	34L2•N	34L3•N	42L1•N	42L2•N	
8000	V	N							34V1•N	44V2•N	44V3•N			
10000	L	O							34L1•O	34L2•O	44L3•O	42L1•O		
10000	V	O						34V0•O		44V2•O	44S3•O	42S1•O		
12500	L	P							34L1•P	44L2•P	44L3•P			
12500	V	P							44V1•P	44S2•P	44S3•P			
16000	L	Q				36L2•Q			44L1•Q	44L2•Q				
16000	V	Q						44V0•Q		44S2•Q				
20000	L	R		38L2•R	36L1•R				44L1•R	44L2•R				
20000	V	R							44S1•R					
25000	L	S		38L1•S			46L2•S	44L0•S	44M1•S					
25000	V	S					46S2•S							
32000	L	T				46L1•T	46L2•T							
32000	V	T				46S1•T								
40000	L	U		48L1•U	48L2•U									
40000	V	U		48S1•U										
50000	L	V		48L0•V										
50000	V	V		48S0•V										

DRH Size 1

DRH Size 2

DRH Size 3

DRH Size 4

DRH 4 cylindrical motor

## KEY AND EXAMPLE OF IDENTIFYING CHARACTERISTICS OF THE HOISTS AND TROLLEYS USING CODES

DRH HOIST	DST TROLLEY	DRT TROLLEY
<p>Size: 1 - 2 - 3 - 4</p> <p>N° of rope falls: 2 = 2 falls (2/1) 4 = 4 falls (4/1) 6 = 6 falls (6/1) 8 = 8 falls (8/1)</p> <p>Gearbox type: © M-Cylindrical = Slow 4 m/min with 4/1 falls © S-Cylindrical = Fast 3 m/min with 8/1 falls 4 m/min with 6/1 falls 6 m/min with 4/1 falls 12 m/min with 2/1 falls</p> <p>L = Slow 2 m/min with 8/1 falls 2.7 m/min with 6/1 falls 4 m/min with 4/1 falls 8 m/min with 2/1 falls</p> <p>V = Fast 6 m/min with 4/1 falls 12 m/min with 2/1 falls</p> <p>0 = 1 Bm (M3) 1 = 1 Am (M4) 2 = 2 m (M5) 3 = 3 m (M6)</p> <p>Hoist speed: S = 1 Speed W = 2 Speed</p> <p>Capacity abbreviation: L = 5000 kg</p> <p>Type of drum: N = Standard C = Short L = Long 1 = Extra long - X1 (1<sup>st</sup> size) 2 = Extra long - X2 (2<sup>nd</sup> size) X = Special</p>	<p>Configuration type Monorail suspended</p> <p>Size: 1 - 2 - 3 - 4</p> <p>Trolley speed: m/min E = 8 F = 10 G = 16 H = 20 D = 16/4 W = 20/5</p> <p>Version: A = Normal B = Low headroom C = Articulated D = Oscillating</p>	<p>Configuration type Double girder</p> <p>Size: 1 - 2 - 3 - 4</p> <p>Gauge: mm A = 1000 B = 1200 C = 1400 D = 2240 E = 2800 X = Special</p> <p>Version: 0 = Hoist on trolley S = Suspended T = Transversal</p> <p>Trolley speed: m/min E = 8 F = 10 G = 16 H = 20 D = 16/4 W = 20/5</p>

# TECHNICAL SPECIFICATIONS AND DATA

CAPACITY (kg)	HOIST FEM GROUP	DRH TYPE	DATA OF DRH ELECTRIC WIRE ROPE HOISTS											TYPE OF TROLLEY ON THE HOIST		
			SPEED AT 50 HZ (m/min)		MOTOR POWER (kW)		HOOK RUN (m) WITH DRUM (1)					ROPE (1)		MONORAIL DST - N/R	DOUBLE GIRDER DRT	
			1 SPEED	2 SPEED	1 SPEED	2 SPEED	C	N	L	X1	X2	N° OF FALLS	Ø / TYPE (mm)			
800	3m	12L3•D	8	8/2,6	3	3/1	8	12	24	34	45	2/1	7B (7B)	1	1	
	3m	12V3•D	12	12/4	3	3/1	8	12	24	34	45	2/1	7B (7B)	1	1	
	3m	14L3•E	4	4/1,3	3	3/1	4	6	9	14	19	4/1	7B (7B)	1	1	
1000	3m	14V3•E	6	6/2	3	3/1	4	6	9	14	19	4/1	7B (7B)	1	1	
	2m	12L2•E	8	8/2,6	3	3/1	8	12	24	34	45	2/1	7B (7B)	1	1	
	3m	12L3•E	8	8/2,6	3	3/1	8	12	24	34	45	2/1	7B (7B)	1	1	
	2m	12V2•E	12	12/4	3	3/1	8	12	24	34	45	2/1	7B (7B)	1	1	
	3m	22V3•E	12	12/4	5	5/1,65	10	14	26	34	43	2/1	8M (8B)	1	1	
	3m	14L3•F	4	4/1,3	3	3/1	4	6	9	14	19	4/1	7B (7B)	1	1	
1250	3m	14V3•F	6	6/2	3	3/1	4	6	9	14	19	4/1	7B (7B)	1	1	
	1Am	12L1•F	8	8/2,6	3	3/1	8	12	24	34	45	2/1	7B (7B)	1	1	
	3m	12L3•F	8	8/2,6	3	3/1	8	12	24	34	45	2/1	7M (7A)	1	1	
	1Am	12V1•F	12	12/4	3	3/1	8	12	24	34	45	2/1	7B (7B)	1	1	
	2m	22V2•F	12	12/4	5	5/1,65	10	14	26	34	43	2/1	9B (9B)	1	1	
	3m	22V3•F	12	12/4	5	5/1,65	10	14	26	34	43	2/1	8M (8B)	1	1	
1600	3m	14L3•G	4	4/1,3	3	3/1	4	6	9	14	19	4/1	7B (7B)	1	1	
	3m	14V3•G	6	6/2	3	3/1	4	6	9	14	19	4/1	7B (7B)	1	1	
	1Am	12L1•G	8	8/2,6	3	3/1	8	12	24	34	45	2/1	7M (7A)	1	1	
	2m	12L2•G	8	8/2,6	3	3/1	8	12	24	34	45	2/1	7M (7A)	1	1	
	3m	22L3•G	8	8/2,6	5	5/1,65	10	14	26	34	43	2/1	8A (8A)	1	1	
	2m	22V2•G	12	12/4	5	5/1,65	10	14	26	34	43	2/1	9B (9B)	1	1	
2000	3m	32V3•G	12	12/4	10	10/3,3	10	14	28	37	47	2/1	12M (12A)	2	2	
	2m	14L2•H	4	4/1,3	3	3/1	4	6	9	14	19	4/1	7B (7B)	1	1	
	3m	14L3•H	4	4/1,3	3	3/1	4	6	9	14	19	4/1	7B (7B)	1	1	
	2m	14V2•H	6	6/2	3	3/1	4	6	9	14	19	4/1	7B (7B)	1	1	
	3m	24V3•H	6	6/2	5	5/1,65	5	7	10	14	18	4/1	8M (8B)	2	1	
	1Am	12L1•H	8	8/2,6	3	3/1	8	12	24	34	45	2/1	7A (7A)	1	1	
	2m	22L2•H	8	8/2,6	5	5/1,65	10	14	26	34	43	2/1	9B (9B)	1	1	
	3m	22L3•H	8	8/2,6	5	5/1,65	10	14	-	-	-	2/1	8A	1	1	
	1Am	22V1•H	12	12/4	5	5/1,65	10	14	26	34	43	2/1	9B (9B)	1	1	
	2m	32V2•H	12	12/4	10	10/3,3	10	14	28	37	47	2/1	13B (13B)	2	2	
	3m	32V3•H	12	12/4	10	10/3,3	10	14	28	37	47	2/1	12M (12A)	2	2	
	2500	1Am	14L1•I	4	4/1,3	3	3/1	4	6	9	14	19	4/1	7B (7B)	1	1
3m		14L3•I	4	4/1,3	3	3/1	4	6	9	14	19	4/1	7M (7A)	1	1	
1Am		14V1•I	6	6/2	3	3/1	4	6	9	14	19	4/1	7B (7B)	1	1	
2m		24V2•I	6	6/2	5	5/1,65	5	7	10	14	18	4/1	9B (9B)	2	1	
3m		24V3•I	6	6/2	5	5/1,65	5	7	10	14	18	4/1	8M (8B)	2	1	
1Am		22L1•I	8	8/2,6	5	5/1,65	10	14	26	34	43	2/1	9M (9A)	1	1	
2m		22L2•I	8	8/2,6	5	5/1,65	10	14	26	34	43	2/1	9M (9A)	1	1	
3m		32L3•I	8	8/2,6	10	10/3,3	10	14	28	37	47	2/1	12M (12B)	2	2	
2m		32V2•I	12	12/4	10	10/3,3	10	14	28	37	47	2/1	13B (13B)	2	2	
3m		32V3•I	12	12/4	10	10/3,3	10	14	28	37	47	2/1	12M (12A)	2	2	
3200		1Am	14L1•J	4	4/1,3	3	3/1	4	6	9	14	19	4/1	7M (7A)	1	1
		1Bm	14V0•J	6	6/2	3,5	3,5/1,1	4	6	9	14	19	4/1	7M (7A)	1	1
	2m	14L2•J	4	4/1,3	3	3/1	4	6	9	14	19	4/1	7M (7A)	1	1	
	3m	24L3•J	4	4/1,3	5	5/1,65	5	7	10	14	18	4/1	8A (8A)	2	1	
	2m	24V2•J	6	6/2	5	5/1,65	5	7	10	14	18	4/1	9B (9B)	2	1	
	3m	34V3•J	6	6/2	10	10/3,3	5	7	10	14	19	4/1	12M (12A)	3	2	
	1Am	22L1•J	8	8/2,6	5	5/1,65	10	14	26	34	43	2/1	9A (9A)	1	1	
	2m	32L2•J	8	8/2,6	10	10/3,3	10	14	28	37	47	2/1	13B (13B)	2	2	
	3m	32L3•J	8	8/2,6	10	10/3,3	10	14	28	37	47	2/1	12M (12A)	2	2	
	2m	32V2•J	12	12/4	10	10/3,3	10	14	28	37	47	2/1	13B (13B)	2	2	
	3m	42V3•J	12	12/4	16	16/5,3	12	16	32	45	58	2/1	15M (15A)	3	3	
	4000	1Am	14L1•K	4	4/1,3	3	3/1	4	6	9	14	19	4/1	7A (7A)	1	1
2m		24L2•K	4	4/1,3	5	5/1,65	5	7	10	14	18	4/1	9B (9B)	2	1	
3m		24L3•K	4	4/1,3	5	5/1,65	5	7	10	14	-	4/1	8A	2	1	
1Am		24V1•K	6	6/2	5	5/1,65	5	7	10	14	18	4/1	9B (9B)	2	1	
2m		34V2•K	6	6/2	10	10/3,3	5	7	10	14	19	4/1	13B (13B)	3	2	
3m		34V3•K	6	6/2	10	10/3,3	5	7	10	14	19	4/1	12M (12A)	3	2	
1Am		32L1•K	8	8/2,6	10	10/3,3	10	14	28	37	47	2/1	13B (13B)	2	2	
2m		32L2•K	8	8/2,6	10	10/3,3	10	14	28	37	47	2/1	13M (13B)	2	2	
3m		32L3•K	8	8/2,6	10	10/3,3	10	14	28	37	47	2/1	12A (12A)	2	2	
1Am		32V1•K	12	12/4	10	10/3,3	10	14	28	37	47	2/1	13B (13B)	2	2	
2m		42V2•K	12	12/4	16	16/5,3	12	16	32	45	58	2/1	16B (16B)	3	3	
3m		42V3•K	12	12/4	16	16/5,3	12	16	32	45	58	2/1	15M (15A)	3	3	
5000	1Am	24L1•L	4	4/1,3	5	5/1,65	5	7	10	14	18	4/1	9M (9A)	2	1	
	1Bm	24V0•L	6	6/2	5,5	5,5/1,8	5	7	10	14	18	4/1	9M (9A)	2	1	
	2m	24L2•L	4	4/1,3	5	5/1,65	5	7	10	14	18	4/1	9M (9A)	2	1	
	3m	34L3•L	4	4/1,3	10	10/3,3	5	7	10	14	19	4/1	12M (12A)	3	2	
	2m	34V2•L	6	6/2	10	10/3,3	5	7	10	14	19	4/1	13B (13B)	3	2	
	3m	34V3•L	6	6/2	10	10/3,3	5	7	10	14	19	4/1	12M (12A)	3	2	
	1Am	32L1•L	8	8/2,6	10	10/3,3	10	14	28	37	47	2/1	13M (13A)	2	2	
	2m	32L2•L	8	8/2,6	10	10/3,3	10	14	28	37	47	2/1	13M (13A)	2	2	
	3m	42L3•L	8	8/2,6	16	16/5,3	12	16	32	45	58	2/1	15M (15A)	3	3	
	2m	42V2•L	12	12/4	16	16/5,3	12	16	32	45	58	2/1	16B (16B)	3	3	



CAPACITY (kg)	HOIST FEM GROUP	DRH TYPE	DATA OF DRH ELECTRIC WIRE ROPE HOISTS											TYPE OF TROLLEY ON THE HOIST	
			SPEED AT 50 HZ (m/min)		MOTOR POWER (kW)		HOOK RUN (m) WITH DRUM <sup>(1)</sup>					ROPE <sup>(1)</sup>		MONORAIL DST - N/R	DOUBLE GIRDER DRT
			1 SPEED	2 SPEED	1 SPEED	2 SPEED	C	N	L	X1	X2	N° OF FALLS	Ø / TYPE (mm)		
6300	1Am	24L1•M	4	4/1,3	5	5/1,65	5	7	10	14	18	4/1	9A (9A)	2	1
	2m	34L2•M	4	4/1,3	10	10/3,3	5	7	10	14	19	4/1	13B (13B)	3	2
	3m	34L3•M	4	4/1,3	10	10/3,3	5	7	10	14	19	4/1	12M (12A)	3	2
	2m	34V2•M	6	6/2	10	10/3,3	5	7	10	14	19	4/1	13B (13B)	3	2
	3m	44V3•M	6	6/2	16	16/5,3	6	8	11	17	24	4/1	15M (15A)	4	3
	1Am	32L1•M	8	8/2,6	10	10/3,3	10	14	28	37	47	2/1	13A (13A)	2	2
	2m	42L2•M	8	8/2,6	16	16/5,3	12	16	32	45	58	2/1	16B (16B)	3	3
	3m	42L3•M	8	8/2,6	16	16/5,3	12	16	32	45	58	2/1	15A (15A)	3	3
	1Am	42V1•M	12	12/4	16	16/5,3	12	16	32	45	58	2/1	16B (16B)	3	3
8000	1Am	34L1•N	4	4/1,3	10	10/3,3	5	7	10	14	19	4/1	13B (13B)	3	2
	2m	34L2•N	4	4/1,3	10	10/3,3	5	7	10	14	19	4/1	13M (13B)	3	2
	3m	34L3•N	4	4/1,3	10	10/3,3	5	7	10	14	19	4/1	12A (12A)	3	2
	1Am	34V1•N	6	6/2	10	10/3,3	5	7	10	14	19	4/1	13B (13B)	3	2
	2m	44V2•N	6	6/2	16	16/5,3	6	8	11	17	24	4/1	16B (16B)	4	3
	3m	44V3•N	6	6/2	16	16/5,3	6	8	11	17	24	4/1	15M (15A)	4	3
	1Am	42L1•N	8	8/2,6	16	16/5,3	12	16	32	45	58	2/1	16M (16M)	3	3
	2m	42L2•N	8	8/2,6	16	16/5,3	12	16	32	45	58	2/1	16M (16M)	3	3
	1Am	34L1•O	4	4/1,3	10	10/3,3	5	7	10	14	19	4/1	13M (13A)	3	2
10000	1Bm	34V0•O	6	6/2	11	11/3,6	5	7	10	14	19	4/1	13M (13A)	3	2
	2m	34L2•O	4	4/1,3	10	10/3,3	5	7	10	14	19	4/1	13M (13A)	3	2
	3m	44L3•O	4	4/1,3	16	16/5,3	6	8	11	17	24	4/1	15M (15A)	4	3
	2m	44V2•O	6	6/2	16	16/5,3	6	8	11	17	24	4/1	16B (16B)	4	3
	3m	©44S3•O	6	6/2	24	24/7,8	6	8	11	17	24	4/1	15M (15A)	4	3
	1Am	42L1•O	8	8/2,6	16	16/5,3	12	16	32	45	58	2/1	16A (16A)	3	3
	1Am	©42S1•O	12	12/4	24	24/7,8	12	16	32	45	58	2/1	16A (16A)	3	3
	1Am	34L1•P	4	4/1,3	10	10/3,3	5	7	10	14	19	4/1	13A (13A)	3	2
	2m	44L2•P	4	4/1,3	16	16/5,3	6	8	11	17	24	4/1	16B (16B)	4	3
12500	3m	44L3•P	4	4/1,3	16	16/5,3	6	8	11	17	24	4/1	15A (15A)	4	3
	1Am	44V1•P	6	6/2	16	16/5,3	6	8	11	17	24	4/1	16B (16B)	4	3
	2m	©44S2•P	6	6/2	24	24/7,8	6	8	11	17	24	4/1	16B (16B)	4	3
	3m	©44S3•P	6	6/2	24	24/7,8	6	8	11	17	24	4/1	15A (15A)	4	3
	2m	36L2•Q	2,7	2,7/0,9	10	10/3,3	-	4	8,8	11,5	15	6/1	13A1	-	3
	1Am	44L1•Q	4	4/1,3	16	16/5,3	6	8	11	17	24	4/1	16M (16M)	4	3
	1Bm	44V0•Q	6	6/2	18	18/5,9	6	8	11	17	24	4/1	16M (16M)	4	3
	2m	44L2•Q	4	4/1,3	16	16/5,3	6	8	11	17	24	4/1	16M (16M)	4	3
	1Am	©44S1•Q	6	6/2	24	24/7,8	6	8	11	17	24	4/1	16M (16M)	4	3
16000	2m	©44S2•Q	6	6/2	24	24/7,8	6	8	11	17	24	4/1	16M (16M)	4	3
	1Am	36L1•R	2,7	2,7/0,9	10	10/3,3	-	4	8,8	11,5	15	6/1	13A1	-	3
	1Am	44L1•R	4	4/1,3	16	16/5,3	6	8	11	17	24	4/1	16A (16A)	4	3
	1Am	©44S1•R	6	6/2	24	24/7,8	6	8	11	17	24	4/1	16A (16A)	4	3
	2m	38L2•R	2	2/0,7	10	10/3,3	-	-	6	8	10,8	8/1	13A1	-	3
	2m	44L2•R	4	4/1,3	16	16/5,3	6	8	11	17	24	4/1	16A1(16A)	4	3
	1Bm	44L0•S	4	4/1,3	18	18/5,9	6	8	11	17	24	4/1	16A1	-	3
	1Am	38L1•S	2	2/0,7	10	10/3,3	-	-	6	8	10,8	8/1	13A1(13A1)	-	3
	1Am	©44M1•S	4	4/1,3	24	24/7,8	6	8	11	17	24	4/1	16,2A	-	3
20000	2m	46L2•S	2,7	2,7/0,9	16	16/5,3	-	5	10	14	19	6/1	16A	-	3
	2m	©46S2•S	4	4/1,3	24	24/7,8	-	5	10	14	19	6/1	16A	-	3
	1Am	46L1•T	2,7	2,7/0,9	16	16/5,3	-	5	10	14	19	6/1	16A	-	3
	1Am	©46S1•T	4	4/1,3	24	24/7,8	-	5	10	14	19	6/1	16A	-	3
	2m	46L2•T	2,7	2,7/0,9	16	16/5,3	-	5	10	14	19	6/1	16A1	-	3
	1Am	48L1•U	2	2/0,7	16	16/5,3	-	3	7	10	13,5	8/1	16A	-	4
	1Am	©48S1•U	3	3/1	24	24/7,8	-	3	7	10	13,5	8/1	16A	-	4
	2m	48L2•U	2	2/0,7	16	16/5,3	-	3	7	10	13,5	8/1	16A1	-	4
	50000	1Bm	48L0•V	2	2/0,7	18	18/5,9	-	3	7	10	13,5	8/1	16A1	-
1Bm		©48S0•V	3	3/1	27	27/8,8	-	3	7	10	13,5	8/1	16A1	-	4

NOTES :

(1) The hoists with 2 falls with drum L, X1, X2 and hoists with 4 falls with drum X2 use anti-twist ropes.

The type of anti-twist rope is shown in brackets.

© DRH4 version with cylindrical motor.

**BREAKING LOAD OF ROPES ( MINIMUM GUARANTEED KN )**

HOIST TYPE →	DRH 1																								DRH 2				DRH 3				DRH 4											
	Ø ROPE (mm) →																								Ø 8				Ø 12				Ø 16,2											
	STRENGTH CLASS →																								B	M	A	M	A	B	M	A	M	A	B	M	A	A1	M	A	B	M	A	A1
Normal (kN)	30,4	42,1	48,1	42,0	61,6	53,1	69,6	74,6	121,7	138,7	102,0	142,5	163,4	154,0	189,7	219,2	176,9	215,9	236,0	268,0	296,0																							
Anti-twist (kN)	35,3	-	48,8	46,1	60,5	58,4	-	76,6	-	136,2	121,8	-	159,8	-	-	212,7	184,4	242,1	255,0	-																								

**TROLLEY DATA AND MOTOR POWER ( MAXIMUM THAT CAN BE SUPPLIED = KW ) AT ONE AND TWO TRAVEL SPEEDS**

ELECTRIC TRAVEL TROLLEY		1 SPEED: 8 OR 10 m/min <sup>(1)</sup>				1 SPEED: 16 OR 20 m/min <sup>(1)</sup>				2 SPEED: 16/4 OR 20/5 m/min <sup>(1)</sup>			
		REDUCER RATIO		TROLLEY MOTOR		REDUCER RATIO		TROLLEY MOTOR <sup>(2)</sup>		GEARBOX RATIO		TROLLEY MOTOR	
		WITH m/min SPEED		TYPE	POWER	WITH m/min SPEED		TYPE	POWER	WITH m/min SPEED		TYPE	POWER
TYPE - SIZE		8	10	4 POLE	kW	16	20	2 POLE	kW	16/4	20/5	2/8 POLE	kW
DST - N/R Monorail	1 - 2	τ1	τ2	71 - 4	0,16	τ1	τ2	71 - 2	0,32	τ1	τ2	71 - D	0,40/0,09
	3	τ1	τ2	80 - 4	0,32	τ1	τ2	80 - 2	0,63	τ1	τ2	80 - D	0,50/0,12
	4	τ1	τ2	80 - 4	0,32	τ1	τ2	80 - 2	0,63	τ1	τ2	80 - D	0,63/0,15
DRT Double girder	1	τ1	τ2	71 - 4	0,16	τ1	τ2	71 - 2	0,32	τ1	τ2	71 - D	0,40/0,09
	2	τ1	τ2	80 - 4	0,32	τ1	τ2	80 - 2	0,63	τ1	τ2	80 - D	0,50/0,12
	3	τ1	τ2	80 - 4	0,32	τ1	τ2	80 - 2	0,63	τ1	τ2	80 - D	0,63/0,15
		τ1	τ2	100 - 4	0,63	τ1	τ2	100 - 2	1,25	τ1	τ2	100 - D	1,25/0,31
4	τ1	τ2	100 - 4	0,63	τ1	τ2	100 - 2	1,25	τ1	τ2	100 - D	1,25/0,31	

NOTES: For combinations with double gear motor see page 35

<sup>(1)</sup> The lifting and travel speeds and powers of the related motors refer to three-phase voltage with 50Hz frequency. They have to be increased 20% for a frequency of 60Hz.

<sup>(2)</sup> With 2 poles motors per inverter the powers are: 71-2 = 0.5kW; 80-2 = 0.8kW; 100-2 = 2kW

**POSITION OF THE WHEELS ON THE BEAM FOR ALL DST TROLLEYS**

DST N/S R	Ø R WHEEL (mm)	DIMENSIONS (mm)			MAX. THICKNESS (mm)
		i	a	b	
DST 1	100	8	35	18	20
DST 2	125	12	35	29	23
DST 3	160	17	45	34	35
DST 4	200	19	50	39	41

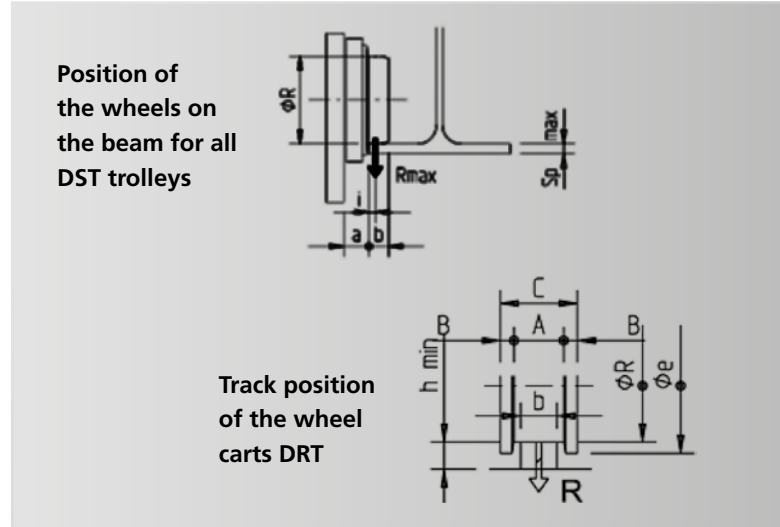

**DIMENSIONS OF DRT WHEELS AND RELATIVE RAILS**

DRT	Ø R WHEEL (mm)	DIMENSIONS (mm)						
		WHEEL				RAIL		
		A	B	C	Ø e	h MIN.	b MIN.	b MAX
DRT 1	125	50	15	80	150	30	30	40
DRT 2	160	55	19	93	190	30	30	45
DRT 3	200	60	20	100	230	30	40	50
DRT 4	250	70	20	110	280	40	50	60

**FIXING OF THE DRH WIRE ROPE HOISTS IN SUSPENDED AND STANDING EXECUTION**

Fixing of 2 and 4 fall hoists in suspended execution: Detail of the hole and connection area of the universal eyebolt

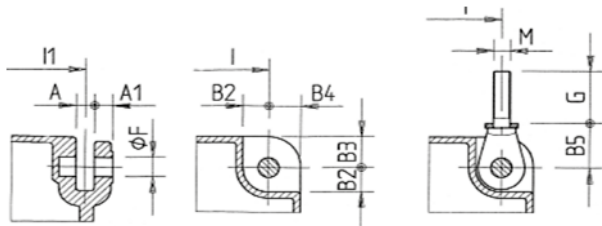

The universal eyebolt is supplied as a standard. For dimensions I and I1 see the DRH standing/suspended page.

Fixing of 2, 4, 6 and 8 fall hoists in standing execution: Detail of the support foot and the connection area of the universal eyebolt (2 and 4 falls) and stay bolts (6 and 8 falls)

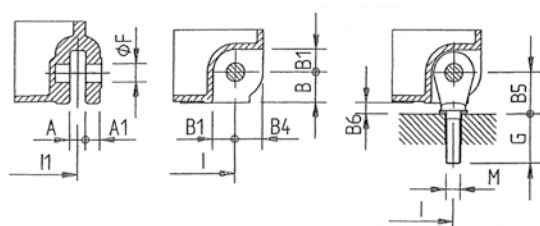

The universal eyebolt (2 and 4 falls) or stay bolt (6 and 8 falls) is supplied as a standard. For dimensions I and I1 see the DRH standing/suspended page.

N° OF ROPE FALLS	DHR TYPE	OVERALL DIMENSIONS (mm)											
		A	A1	B	B1	B2	B3	B4	B5	B6	ØF	M	G
2/1 - 4/1	1	20	20	37	21	21	35	35	50	13	20	16x2	65
	2	22	22	42	31	31	40	40	55	13	25	20x2,5	70
	3	32	32	48	36	36	55	55	76	28	35	24x3	93
	4	42	42	60	38	46	70	70	89	29	45	30x3,5	108
6/1 - 8/1	3	32	32	48	36	-	-	-	48	-	35	20x2,5	55
	4	42	42	60	38	-	-	-	60	-	45	27x3	57

NOTES – Fixing 2, 4, 6 and 8 fall hoists in standing execution for applications on trolleys not supplied by Donati:

- With the universal eyebolt (2 and 4 falls), the headroom of the hoist (H2 DRH dimension) needs to be increased by the dimension "B6" compared to the hoist support surface.
- With the stay bolt (6 and 8 falls) the headroom does not need to be increased by the dimension "B6".

**OVERALL DIMENSIONS - WEIGHTS**

# DRH SERIES ELECTRIC WIRE ROPE HOISTS WITH 2 AND 4 ROPE FALLS IN STANDING OR SUSPENDED EXECUTION

Reactions on the supports, see page 29

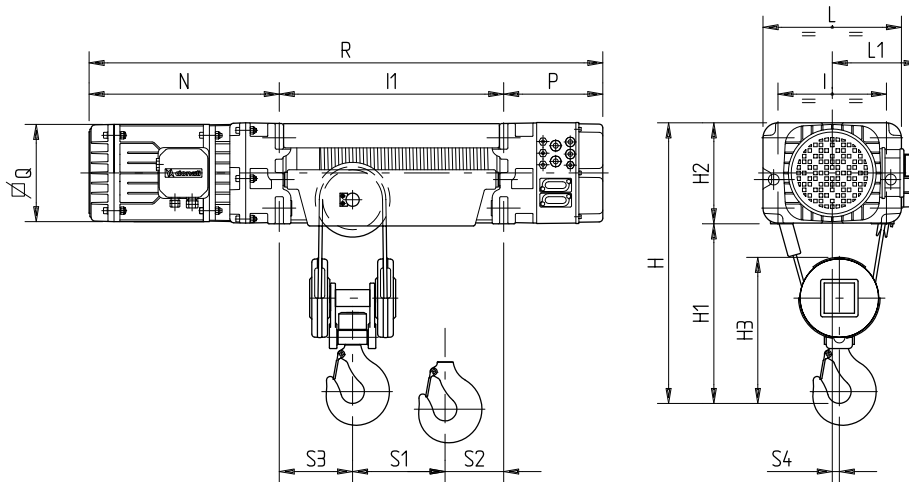

$$S2 = I1 - S3 - S1$$

\* For DRH3 and DRH4 with L.V., dimension P becomes: DRH3 = 330; DRH4 = 360

N° OF ROPE FALLS	DHR TYPE	OVERALL DIMENSIONS (mm)										
		H	H1	H2	H3	I	L	L1	N	P	Q	S4
2/1	1	690	460	230	390	250	320	210	480	255	225	28
	2	820	550	270	445	290	370	235	525	270	260	30
	3	1090	710	380	595	370	480	290	705	205	300	40
	4	1390	920	470	750	460	600	360	855	220	340	45
	⊙4	1390	920	470	750	460	600	360	1015	220	340	45
4/1	1	650	420	230	345	250	320	210	480	255	225	15
	2	750	480	270	390	290	370	235	525	270	260	19
	3	1020	640	380	540	370	480	290	705	205	300	23
	4	1320	850	470	700	460	600	360	855	220	340	25
	⊙4	1320	850	470	700	460	600	360	1015	220	340	25

N° OF ROPE FALLS	DHR TYPE	DRUM C				DRUM N				DRUM L				DRUM X1				DRUM X2				WEIGHT (kg) WITH DRUM TYPE				
		I1	R	S1	S3	I1	R	S1	S3	I1	R	S1	S3	I1	R	S1	S3	I1	R	S1	S3	C	N	L	X1	X2
2/1	1	400	1135	125	95	515	1250	185	95	890	1625	365	95	1200	1935	515	95	1530	2265	680	95	132	141	160	180	200
	2	480	1275	160	100	600	1395	220	100	1000	1795	410	100	1260	2055	530	100	1530	2325	670	100	180	195	215	260	280
	3	600	1510	195	130	740	1650	265	130	1260	2170	515	130	1550	2460	680	130	1940	2850	860	130	460	490	565	590	620
	4	722	1797	220	170	862	1937	290	170	1422	2497	570	170	1852	2927	800	170	2352	3427	1030	170	855	890	1010	1200	1250
	⊙4	722	1957	220	170	862	2097	290	170	1422	2657	570	170	1852	3087	800	170	2352	3587	1030	170	910	945	1065	1255	1305
4/1	1	400	1135	70	150	515	1250	100	150	890	1625	160	165	1200	1935	230	165	1530	2265	300	165	140	150	170	200	220
	2	480	1275	105	180	600	1395	135	180	1000	1795	210	200	1260	2055	280	200	1530	2325	350	200	195	205	235	280	300
	3	600	1510	130	240	740	1650	160	240	1260	2170	240	270	1550	2460	280	270	1940	2850	350	270	515	540	625	650	700
	4	722	1797	150	300	862	1937	180	300	1422	2497	220	300	1852	2927	310	300	2352	3427	410	300	960	1000	1140	1350	1400
⊙4	722	1957	150	300	862	2097	180	300	1422	2657	220	300	1852	3087	310	300	2352	3587	410	300	1015	1055	1195	1405	1455	

⊙ DRH4 hoist with cylindrical motor.

# DRH SERIES ELECTRIC ROPE HOISTS WITH 6 AND 8 ROPE FALLS IN STANDING EXECUTION

Reactions on the supports, see page 29

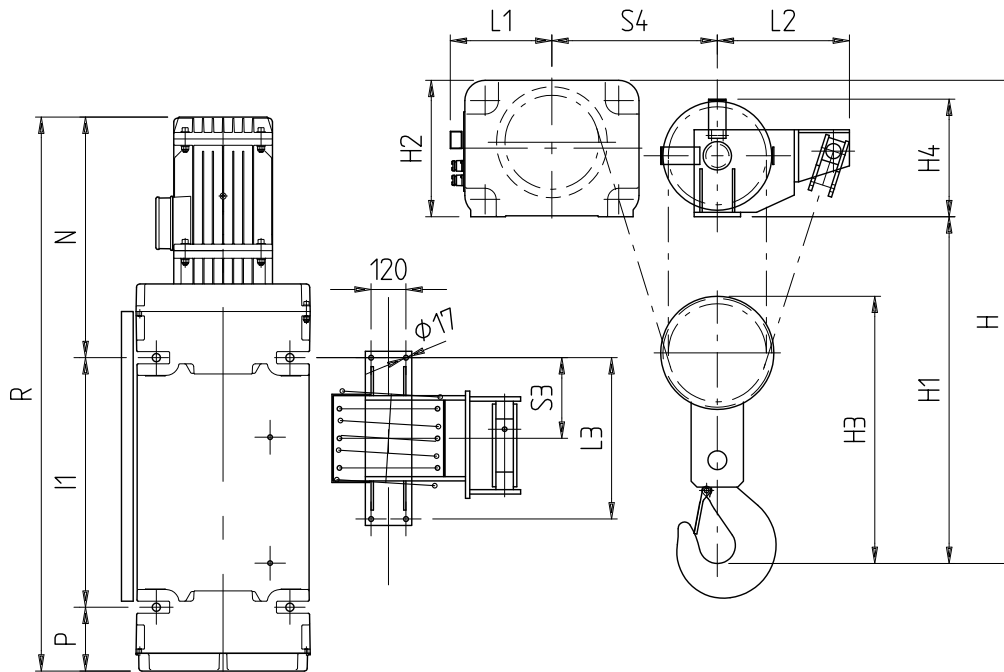

N° OF ROPE FALLS	DHR TYPE	OVERALL DIMENSIONS (mm)										
		H	H1	H3	H4	L2	L3	S4	L1	N	P	
6/1	3	1435	1055	777	330	350	330	415	290	705	205	
	4	1665	1195	922	410	355	360	470	360	855	220	
	⊙4	1665	1195	922	410	355	360	470	360	1015	220	
8/1	3	1435	1055	777	330	420	450	515	290	705	205	
	4	1665	1195	922	410	455	556	570	360	855	220	
	⊙4	1665	1195	922	410	455	556	570	360	1015	220	

N° OF ROPE FALLS	DHR TYPE	DRUM N			DRUM L			DRUM X1			DRUM X2			WEIGHT (kg) WITH DRUM TYPE			
		I1	R	S3	I1	R	S3	I1	R	S3	I1	R	S3	N	L	X1	X2
6/1	3	740	1650	165	1260	2170	165	1550	2460	165	1940	2850	165	595	680	710	760
	4	862	1937	180	1422	2497	180	1852	2927	180	2352	3427	180	1070	1210	1420	1470
	⊙4	862	2097	180	1422	2657	180	1852	3087	180	2352	3587	180	1125	1265	1475	1525
8/1	3	-	-	-	1260	2170	225	1550	2460	225	1940	2850	225	-	700	730	780
	4	862	1937	278	1422	2497	278	1852	2927	278	2352	3427	278	1110	1250	1460	1510
	⊙4	862	2097	278	1422	2657	278	1852	3087	278	2352	3587	278	1165	1305	1515	1565

© DRH4 hoist with cylindrical motor.

# DST/N MONORAIL TROLLEYS FOR DRH ELECTRIC WIRE ROPE HOISTS – 2 (2/1) AND 4 (4/1) ROPE FALL VERSIONS

Reactions on the supports, see page 30

DRH series electric wire rope hoists with 2 and 4 rope falls with normal trolley N

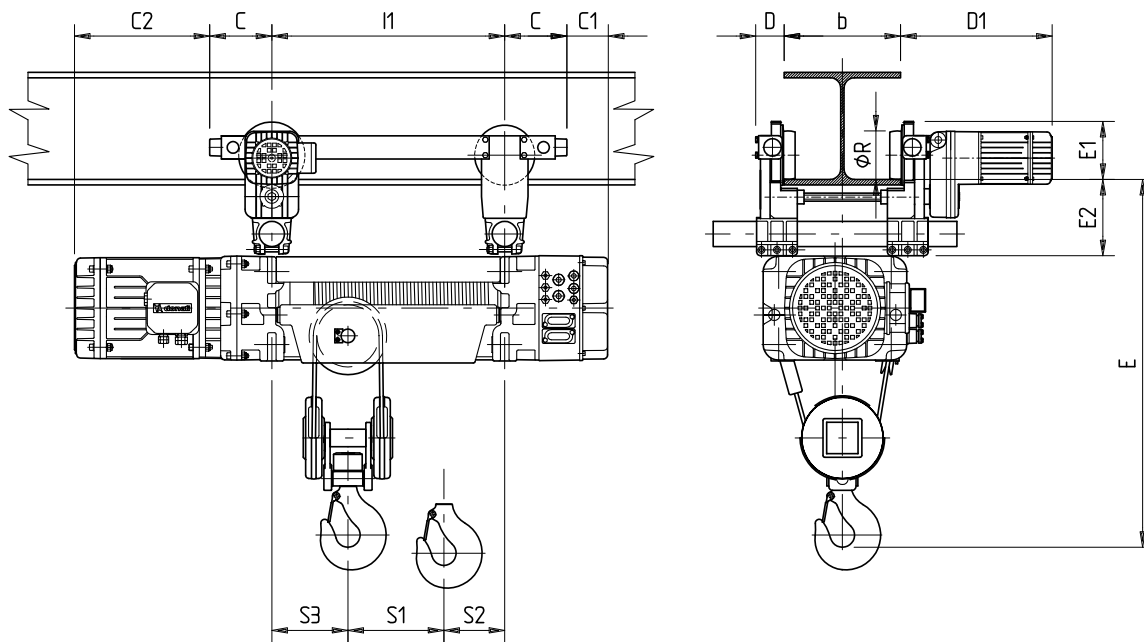

\* For dimensions l1 - S1 - S2 - S3 see page 19

N° OF ROPE FALLS	DHR TYPE	TROLLEY DST N/S	OVERALL DIMENSIONS (mm)								WEIGHT (kg) WITH DRUM TYPE				
			C	C1	C2	D	D1	E	E1	E2	C	N	L	X1	X2
2/1	1	1	140	115	340	66	393	870	130	180	215	220	240	270	290
	2	1	140	130	385	66	393	1000	130	180	260	270	295	326	346
	3	2	160	45	545	75	400	1290	148	195	575	600	675	750	826
	4	3	275	-55	580	90	460	1650	191	255	1120	1155	1270	1480	1650
	⊙4	3	275	-55	740	90	460	1650	191	255	1175	1210	1325	1535	1705
4/1	1	1	140	115	340	66	393	830	128	180	220	230	250	280	300
	2	2	160	110	365	75	400	950	148	195	300	310	335	380	400
	3	3	275	-70	430	90	460	1280	191	255	775	810	880	996	1070
	4	4	325	-105	530	102	468	1620	237	295	1415	1455	1590	1800	1970
	⊙4	4	325	-105	690	102	468	1620	237	295	1470	1510	1645	1855	2025

© DRH4 hoist with cylindrical motor.

N.B.: For the speed, power and position of the wheel see page 18

## BEAM SPECIFICATIONS TABLE FOR DST/N TROLLEYS

TROLLEY	MIN. BEAM WIDTH (mm)	MAX. THICKNESS (mm)	MIN. RADIUS (mm)
DST1N	90	20	–
DST2N	119	23	–
DST3N	135	35	–
DST4N	180	41	–

**Min. beam width** = minimum beam width required

**Minimum radius** = minimum internal radius required for curved beams

**Max. thickness** = maximum beam flange thickness allowed

# DST/S MONORAIL TROLLEYS FOR DRH ELECTRIC WIRE ROPE HOISTS - 2 (2/1) AND 4 (4/1) ROPE FALL VERSIONS - ARTICULATED

DRH series electric wire rope hoists with 2 and 4 rope falls with articulated trolley S

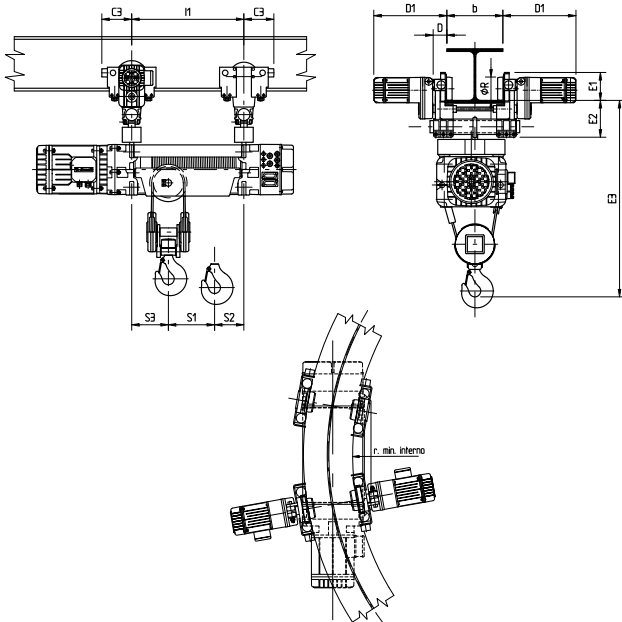

\* For dimensions I1 - S1 - S2 - S3 see page 19

N° OF ROPE FALLS	DHR TYPE	TROLLEY DST/S	OVERALL DIMENSIONS (mm)		
			C3	r MIN.	E3
2/1	1	1	156	1500	960
	2	1	156	1500	1090
	3	2	160	1600	1400
	4	3	280	*1600	1855
4/1	1	1	156	1500	920
	2	2	160	1600	1050
	3	3	280	1600	1485
	4	4	327	1800	1810

N.B.: For the speed, power and position of the wheel see page 18

BEAM SPECIFICATIONS TABLE FOR DST/S TROLLEYS

TROLLEY	MIN. BEAM WIDTH (mm)	MAX. THICKNESS (mm)	MIN. RADIUS (mm)
DST1S	100	20	1500
DST2S	135	23	1600
DST3S	170	35	*1600
DST4S	210	41	1800

\* **DST3S** with DRH4 2 rope falls drum X2 Minimum radius = 1800

**Min. beam width** = minimum beam width required

**Minimum radius** = minimum internal radius required for curved beams

**Max. thickness** = maximum beam flange thickness allowed

# DST/O MONORAIL TROLLEYS FOR DRH ELECTRIC WIRE ROPE HOISTS 2 (2/1) AND 4 (4/1) - OSCILLATING

DRH series electric wire rope hoists with 2 and 4 rope falls in oscillating execution

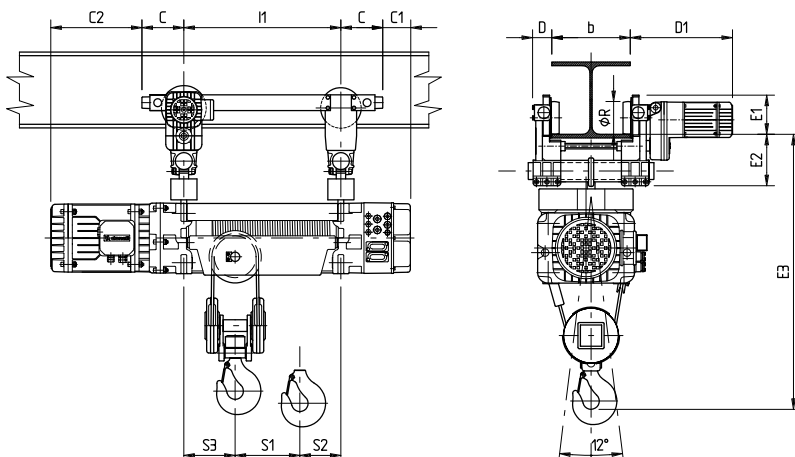

\* For dimensions I1 - S1 - S2 - S3 see page 19

BEAM SPECIFICATIONS TABLE FOR DST/O TROLLEYS

TROLLEY	MIN. BEAM WIDTH (mm)	MAX. THICKNESS (mm)	MIN. RADIUS (mm)
DST1O	100	20	-
DST2O	135	23	-
DST3O	170	35	-
DST4O	210	41	-

**Min. beam width** = minimum beam width required

**Minimum radius** = minimum internal radius required for curved beams

**Max. thickness** = maximum beam flange thickness allowed

# DST/R MONORAIL TROLLEYS FOR DRH ELECTRIC WIRE ROPE HOISTS - 2 FALL (2/1) AND 4 FALL (4/1) VERSIONS

Reactions on the supports, see page 31

DRH series electric wire rope hoists with 2 and 4 rope falls with low headroom trolley R

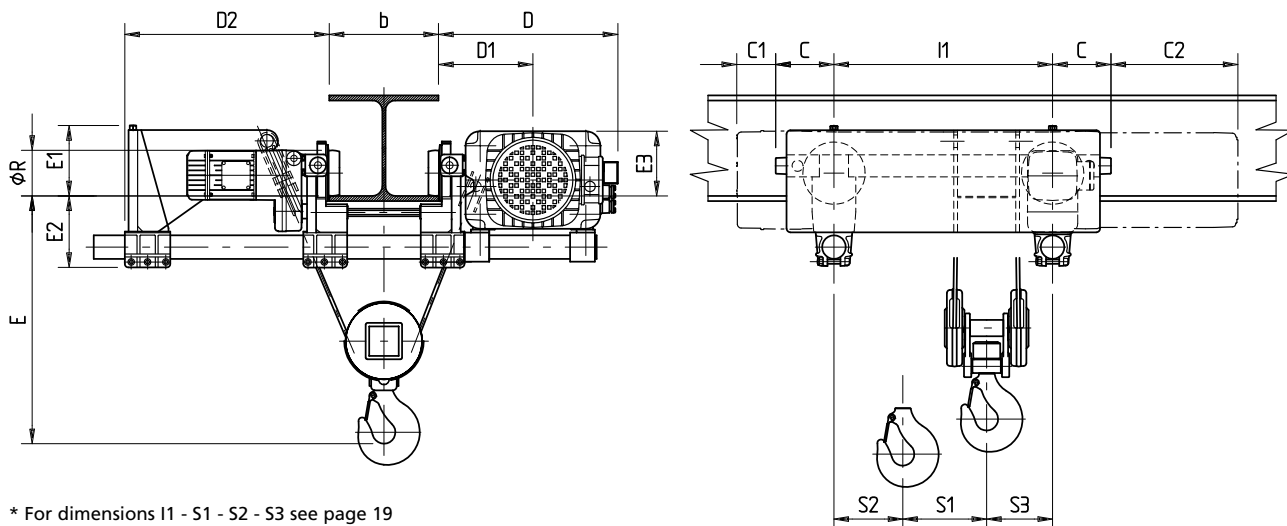

N° OF ROPE FALLS	DRH TYPE	DST-R TROLLEY	OVERALL DIMENSIONS (mm)										WEIGHT (kg) WITH DRUM TYPE						
			D	D1	D2	D2 DRUM (X1-X2)	E1	E1 DRUM (X1-X2)	E2	E3	ØR	C	C1	C2	C	N	L	X1	X2
2/1	1	1	440	230	540	393	140	143	180	145	100	140	115	340	260	270	280	360	390
	2	1	485	250	590	420	200	180	180	185	100	140	130	385	360	370	395	460	490
	3	2	605	315	655	582	317	295	195	295	125	160	45	545	740	770	870	1060	1160
	4	3	755	395	677	677	352	352	255	365	160	275	-55	580	1510	1550	1700	2120	2350
	©4	3	755	395	677	677	352	352	255	365	160	275	-55	740	1565	1605	1755	2175	2405
4/1	1	1	440	230	540	393	140	143	180	145	100	140	115	340	270	280	290	370	400
	2	2	495	265	560	412	195	175	195	180	125	160	110	365	415	425	450	530	560
	3	3	625	335	622	547	286	265	255	265	160	275	-70	430	985	1005	1115	1346	1446
	4	4	760	405	630	630	350	350	295	355	200	325	-105	530	1880	1930	2120	2540	2765
	©4	4	760	405	630	630	350	350	295	355	200	325	-105	690	1935	1985	2175	2595	2820

© DRH4 hoist with cylindrical motor.

N° OF ROPE FALLS	HOOK CLEARANCE E (mm) IN RELATION TO THE WIDTH OF BEAM B (mm) AND SIZE OF THE DRH WIRE ROPE HOIST															
	b = 180 (mm)				b = 220 (mm)				b = 300 (mm)				b = 400 (mm)			
	DRH 1	DRH 2	DRH 3	DRH 4	DRH 1	DRH 2	DRH 3	DRH 4	DRH 1	DRH 2	DRH 3	DRH 4	DRH 1	DRH 2	DRH 3	DRH 4
2/1	630	640	680	830	670	680	680	830	770	780	780	880	890	900	900	1000
4/1	480	500	610	790	530	550	610	790	620	650	650	790	740	770	770	850

N.B.: For the speed, power and position of the wheel see page 18

## BEAM SPECIFICATIONS TABLE FOR DST/R TROLLEYS

TROLLEY	MIN. BEAM WIDTH (mm)	MAX. THICKNESS (mm)
DST1R	90	20
DST2R	119	23
DST3R	135	35
DST4R	180	41

# DRT DOUBLE GIRDER TROLLEYS FOR DRH STANDING ELECTRIC ROPE HOISTS - 2 FALL (2/1) AND 4 FALL (4/1) VERSIONS

Reactions on the supports, see page 32

DRH series electric wire rope hoists with 2 and 4 rope falls with DRT double girder trolley, in standing configuration

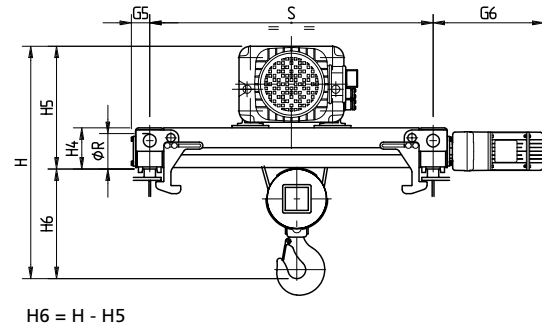
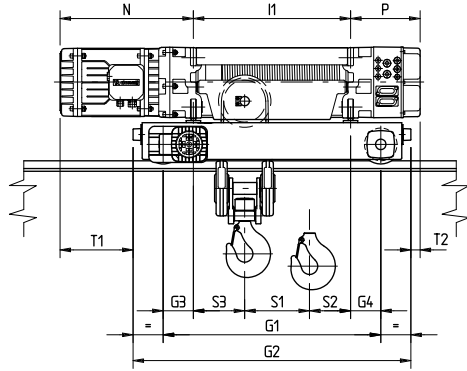

For dimensions I1 - S1 - S2 - S3 - N - P - H see page 19

(\*) The standard gauge is S=1000 mm, a gauge of S = 1200 mm can be supplied upon request

N° OF ROPE FALLS	DHR TYPE	DRT TROLLEY	GAUGE TROLLEY S (mm)	TYPE OF DRUM DRH	WEIGHT DRH + DRT (kg)	OVERALL DIMENSIONS (mm)										
						G1	G2	G3	G4	G5	G6	T1	T2	Ø R	H4	H5
2/1 4/1	1	1	1000	C	236	710	940	155	155	66	392	210	-15	125	145	391
				N	250	830	1060	157,5	157,5	66	392	207,5	-17,5	125	145	391
				L	280	1230	1460	170	170	66	392	195	-30	125	145	391
				X1	306	1500	1730	150	150	66	392	215	-10	125	145	391
				X2	336	1770	2000	120	120	66	392	245	20	125	145	39
	2	1	1000	C	296	710	940	115	115	66	392	295	40	125	145	433
				N	306	830	1060	115	115	66	392	295	40	125	145	433
				L	350	1230	1460	115	115	66	392	295	40	125	145	433
				X1	376	1500	1730	120	120	66	392	290	35	125	145	433
				X2	406	1770	2000	120	120	66	392	290	35	125	145	433
	3	2	1000	C	716	890	1202	145	145	80	461	404	-96	160	190	598
				N	750	1030	1342	145	145	80	461	404	-96	160	190	598
				L	860	1550	1862	145	145	80	461	404	-96	160	190	598
				X1	946	1840	2152	145	145	80	461	404	-96	160	190	598
				X2	1000	2230	2542	145	145	80	461	404	-96	160	190	598
	4	3	1000	C	1252	1060	1446	170	170	90	520	492	-143	200	228	698
				N	1298	1200	1586	170	170	90	520	492	-143	200	228	698
				L	1492	1760	2146	170	170	90	520	492	-143	200	228	698
				X1	1675	2210	2596	180	180	90	520	482	-153	200	228	698
				X2	1865	2710	3096	180	180	90	520	482	-153	200	228	698
©4	3	1000	C	1307	1060	1446	170	170	90	520	652	-143	200	228	698	
			N	1353	1200	1586	170	170	90	520	652	-143	200	228	698	
			L	1547	1760	2146	170	170	90	520	652	-143	200	228	698	
			X1	1730	2210	2596	180	180	90	520	642	-153	200	228	698	
			X2	1920	2710	3096	180	180	90	520	642	-153	200	228	698	
<b>TROLLEYS DRT3 WITH HOISTS DRH4 (25 t)</b>																
4/1	4	3	1000	C	1350	1060	1446	170	170	90	520	492	-143	200	235	727
				N	1397	1200	1586	170	170	90	520	492	-143	200	235	727
				L	1617	1760	2146	170	170	90	520	492	-143	200	235	727
				X1	1822	2210	2596	180	180	90	520	482	-153	200	235	727
				X2	2055	2710	3096	180	180	90	520	482	-153	200	235	727
	©4	3	1000	C	1405	1060	1446	170	170	90	520	652	-143	200	235	727
				N	1452	1200	1586	170	170	90	520	652	-143	200	235	727
				L	1672	1760	2146	170	170	90	520	652	-143	200	235	727
				X1	1877	2210	2596	180	180	90	520	642	-153	200	235	727
				X2	2110	2710	3096	180	180	90	520	642	-153	200	235	727

© DRH4 hoist with cylindrical motor.

N.B.: For the speed, power and dimensions of the wheels see page 18



# DRT DOUBLE GIRDER TROLLEYS FOR DRH SUSPENDED ELECTRIC ROPE HOISTS - 2 FALL (2/1) AND 4 FALL (4/1) VERSIONS

Reactions on the supports, see page 32

DRH series electric wire rope hoists with 2 and 4 rope falls with DRT double girder trolley, in suspended configuration

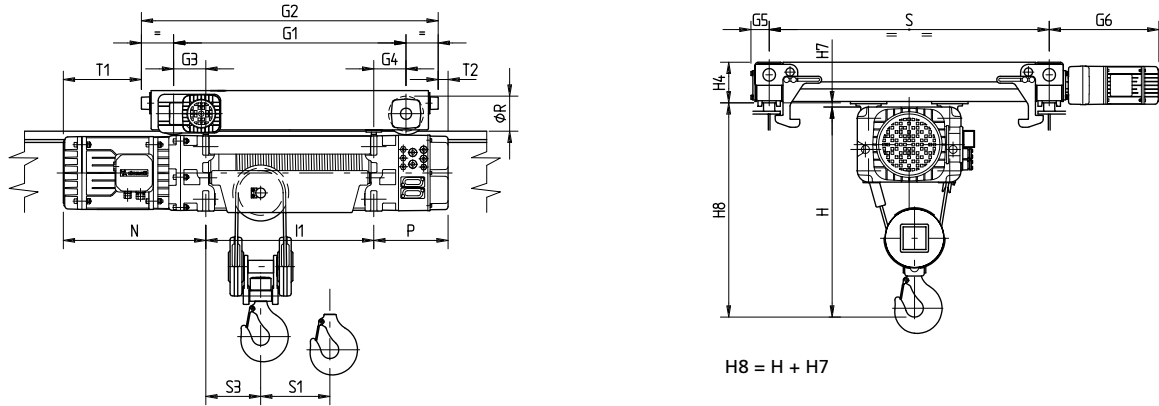

For dimensions I1 - S1 - S2 - S3 - N - P - H see page 19

(\*) The standard gauge is  $S = 1000$  mm, a gauge of  $S = 1200$  mm can be supplied upon request

N° OF ROPE FALLS	DRH TYPE	DRT TROLLEY	GAUGE TROLLEY S (mm)	TYPE OF DRUM DRH	WEIGHT DRH + DRT (kg)	OVERALL DIMENSIONS (mm)										
						G1	G2	G3	G4	G5	G6	T1	T2	Ø R	H4	H7
2/1 4/1	1	1	1000	C	236	710	940	155	155	66	392	210	-15	125	145	13
				N	250	830	1060	157,5	157,5	66	392	207,5	-17,5	125	145	13
				L	280	1230	1460	170	170	66	392	195	-30	125	145	13
				X1	306	1500	1730	150	150	66	392	215	-10	125	145	13
	2	1	1000	C	296	710	940	115	115	66	392	295	40	125	145	15
				N	306	830	1060	115	115	66	392	295	40	125	145	15
				L	350	1230	1460	115	115	66	392	295	40	125	145	15
				X1	376	1500	1730	120	120	66	392	290	35	125	145	15
	3	2	1000	X2	406	1770	2000	120	120	66	392	290	35	125	145	15
				C	716	890	1202	145	145	80	461	404	-96	160	190	11
				N	750	1030	1342	145	145	80	461	404	-96	160	190	11
				L	860	1550	1862	145	145	80	461	404	-96	160	190	11
4	3	1000	X1	946	1840	2152	145	145	80	461	404	-96	160	190	11	
			X2	1000	2230	2542	145	145	80	461	404	-96	160	190	11	
			C	1240	1060	1446	170	170	90	520	492	-143	200	228	11	
			N	1286	1200	1586	170	170	90	520	492	-143	200	228	11	
©4	3	1000	L	1480	1760	2146	170	170	90	520	492	-143	200	228	11	
			X1	1656	2210	2596	180	180	90	520	482	-153	200	228	11	
			X2	1846	2710	3096	180	180	90	520	482	-153	200	228	11	
			C	1295	1060	1446	170	170	90	520	652	-143	200	228	11	
©4	3	1000	N	1341	1200	1586	170	170	90	520	652	-143	200	228	11	
			L	1535	1760	2146	170	170	90	520	652	-143	200	228	11	
			X1	1711	2210	2596	180	180	90	520	642	-153	200	228	11	
			X2	1901	2710	3096	180	180	90	520	642	-153	200	228	11	

©DRH4 hoist with cylindrical motor.

N.B.: For the speed, power and dimensions of the wheels see page 18

# DRT DOUBLE GIRDER TROLLEYS FOR DRH ELECTRIC ROPE HOISTS - TRANSVERSAL VERSION WITH 2 FALL (2/1) AND 4 FALL (4/1) VERSIONS

Reactions on the supports, see page 33

DRH series electric wire rope hoists with 2 and 4 rope falls with DRT double girder trolley, in transversal standing configuration

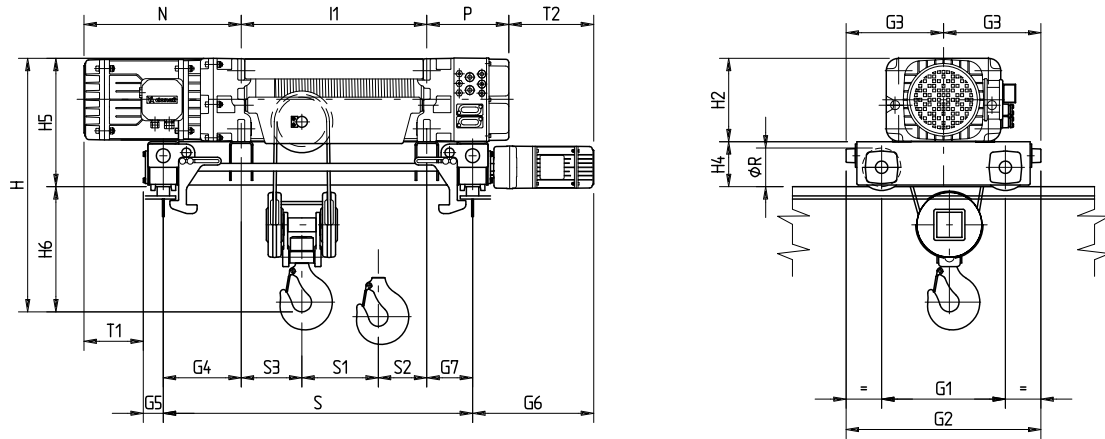

For dimensions l1 - S1 - S2 - S3 - N - P - H2 see page 19

H = H5 + H6

N° OF ROPE FALLS	DRH TYPE	DRT TROLLEY	GAUGE TROLLEY S (mm)	TYPE OF DRUM DRH	WEIGHT DRH + DRT (kg)	OVERALL DIMENSIONS (mm)													
						G1	G2	G3	G4	G5	G6	G7	T1	T2	Ø R	H4	H5	H6	
2/1	1	1	1000	C	216	400	630	315	315	66	392	285	99	422	125	145	375	405	360
				N	226	400	630	315	300	66	392	185	114	322	125	145	375	405	360
				L	270	710	940	470	110	66	392	0	304	137	125	145	375	315	275
	2	1	1000	C	276	400	630	315	267	66	392	253	192	375	125	145	415	485	425
				N	286	400	630	315	252	66	392	148	207	270	125	145	415	485	425
				L	346	710	940	470	200	66	392	0	259	122	125	145	415	405	335
4/1	3	2	1000	C	660	500	812	406	195	80	461	205	430	461	160	190	570	630	570
				N	686	500	812	406	170	80	461	90	455	346	160	190	570	630	570
4	3	3	1000	C	1190	600	986	493	140	90	520	140	625	440	200	228	698	768	722
				N	1240	600	986	493	200	90	520	140	565	440	200	228	698	768	722
	©4	3	1000	C	1245	600	986	493	140	90	520	140	785	440	200	228	698	768	722
				N	1295	600	986	493	200	90	520	140	725	440	200	228	698	768	722

© DRH4 hoist with cylindrical motor.

N.B.: For the speed, power and dimensions of the wheels see page 18

# DRT DOUBLE GIRDER TROLLEYS FOR DRH ELECTRIC ROPE HOISTS - 6 FALL (6/1) VERSION

Reactions on the supports, see page 33

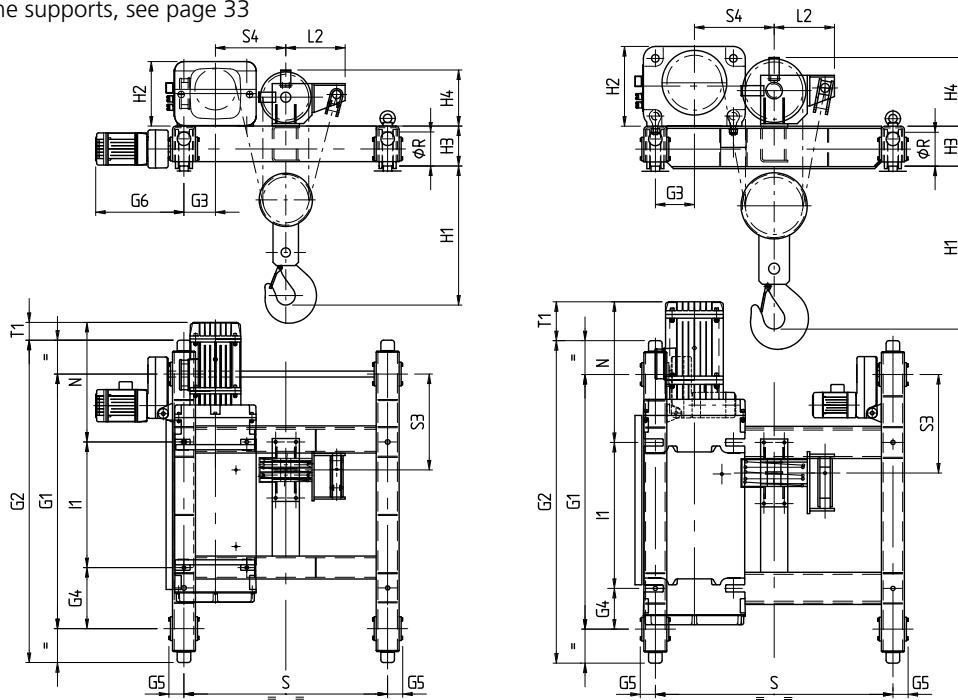

For dimensions I1 - N - H2 - H4 - L2 see page 20

N° OF ROPE FALLS	DHR TYPE	DRT TROLLEY	GAUGE TROLLEY S (mm)	TYPE OF DRUM DRH	WEIGHT DRH + DRT (kg)	OVERALL DIMENSIONS (mm)												
						G1	G2	G3	G4	G5	G6	S3	S4	T1	H1	H3	Ø R	
6/1	3	* 3	1200	N	1120	1500	1900	185	360	90	520	565	415	105	820	235	200	
			1400		1140	1500	1900	185	360	90	520	565	515	105	820	235	200	
			1200	L	1290	2070	2470	185	400	90	520	575	415	95	820	235	200	
			1400		1310	2070	2470	185	400	90	520	575	515	95	820	235	200	
			1200	X1	1380	2500	2900	185	540	90	520	575	415	95	820	235	200	
			1400		1400	2500	2900	185	540	90	520	575	515	95	820	235	200	
	1200	X2	1510	3000	3400	185	410	90	520	575	415	95	820	235	200			
	1400		1530	3000	3400	185	410	90	520	575	515	95	820	235	200			
	6/1	4	** 3	1400	N	1800	1500	1900	230	240	90	-	580	470	255	960	235	200
				2240		2100	1500	1900	650	240	90	-	580	470	255	960	235	200
				2800	L	2400	1500	1900	930	240	90	-	580	470	255	960	235	200
				1400		2000	2070	2470	230	240	90	-	590	470	245	960	235	200
2240				L	2300	2070	2470	650	240	90	-	590	470	245	960	235	200	
2800					2700	2070	2470	930	240	90	-	590	470	245	960	235	200	
6/1		4	** 3	1400	X1	2250	2500	2900	230	240	90	-	590	470	245	960	235	200
				2240		2500	2500	2900	650	240	90	-	590	470	245	960	235	200
				2800	X1	2800	2500	2900	930	240	90	-	590	470	245	960	235	200
				1400		2390	3000	3400	230	240	90	-	590	470	245	960	235	200
				2240	X2	2650	3000	3400	650	240	90	-	590	470	245	960	235	200
				2800		2950	3000	3400	930	240	90	-	590	470	245	960	235	200
6/1	4	** 3	1400	N	1855	1500	1900	230	240	90	-	580	470	415	960	235	200	
			2240		2155	1500	1900	650	240	90	-	580	470	415	960	235	200	
			2800	L	2455	1500	1900	930	240	90	-	580	470	415	960	235	200	
			1400		2055	2070	2470	230	240	90	-	590	470	405	960	235	200	
			2240	L	2355	2070	2470	650	240	90	-	590	470	405	960	235	200	
			2800		2755	2070	2470	930	240	90	-	590	470	405	960	235	200	
	6/1	4	** 3	1400	X1	2305	2500	2900	230	240	90	-	590	470	405	960	235	200
				2240		2555	2500	2900	650	240	90	-	590	470	405	960	235	200
				2800	X1	2855	2500	2900	930	240	90	-	590	470	405	960	235	200
				1400		2445	3000	3400	230	240	90	-	590	470	405	960	235	200
				2240	X2	2705	3000	3400	650	240	90	-	590	470	405	960	235	200
				2800		3005	3000	3400	930	240	90	-	590	470	405	960	235	200

©DRH4 hoist with cylindrical motor.

N.B.: For the speed, power and dimensions of the wheels see page 18

\* The trolley is made with a single gear motor (motor 100)

\*\* The trolley is made with double gear motor (motor 80)

# DRT DOUBLE GIRDER TROLLEYS FOR DRH ELECTRIC ROPE HOISTS - 8 FALL (8/1) VERSION

Reactions on the supports, see page 33

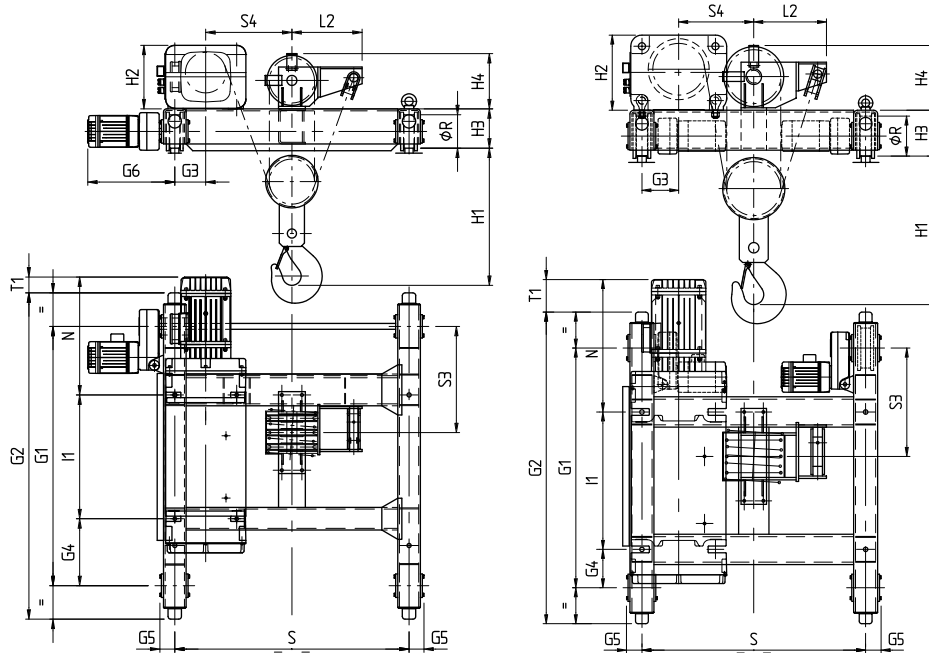

For dimensions I1 - N - H2 - H4 - L2 see page 20

N° OF ROPE FALLS	DHR TYPE	DRT TROLLEY	GAUGE TROLLEY S (mm)	TYPE OF DRUM DRH	WEIGHT DRH + DRT (kg)	OVERALL DIMENSIONS (mm)												
						G1	G2	G3	G4	G5	G6	S3	S4	T1	H1	H3	Ø R	
3	*	3	1400	L	1400	2070	2470	185	400	90	520	635	515	95	820	235	200	
		**	3		2240	1480	2070	2470	605	400	90	-	635	515	95	820	235	200
		**	3		2800	1730	2070	2470	885	400	90	-	635	515	95	820	235	200
		*	3		1400	1480	2500	2900	185	540	90	520	635	515	95	820	235	200
		**	3		2240	1560	2500	2900	605	540	90	-	635	515	95	820	235	200
		**	3		2800	1820	2500	2900	885	540	90	-	635	515	95	820	235	200
	**	3	X2	1400	1580	3000	3400	185	650	90	520	635	515	95	820	235	200	
				2240	1750	3000	3400	605	650	90	-	635	515	95	820	235	200	
				2800	1950	3000	3400	885	650	90	-	635	515	95	820	235	200	
				1400	2000	1500	1950	230	240	97	-	678	470	230	930	287	250	
				2240	2400	1500	1950	550	240	97	-	678	570	230	930	287	250	
				2800	2600	1500	1950	830	240	97	-	678	570	230	930	287	250	
4	***	4	L	1400	2300	2060	2510	230	240	97	-	678	470	230	930	287	250	
				2240	2600	2060	2510	550	240	97	-	678	570	230	930	287	250	
				2800	2800	2060	2510	830	240	97	-	678	570	230	930	287	250	
				1400	2500	2500	2950	230	240	97	-	688	470	220	930	287	250	
				2240	2900	2500	2950	550	240	97	-	688	570	220	930	287	250	
				2800	3100	2500	2950	830	240	97	-	688	570	220	930	287	250	
	**	4	X2	1400	2680	3000	3450	230	240	97	-	688	470	220	930	287	250	
				2240	3030	3000	3450	550	240	97	-	688	570	220	930	287	250	
				2800	3270	3000	3450	830	240	97	-	688	570	220	930	287	250	
				1400	2055	1500	1950	230	240	97	-	678	470	390	930	287	250	
				2240	2455	1500	1950	550	240	97	-	678	570	390	930	287	250	
				2800	2655	1500	1950	830	240	97	-	678	570	390	930	287	250	
©4	***	4	L	1400	2355	2060	2510	230	240	97	-	678	470	390	930	287	250	
				2240	2655	2060	2510	550	240	97	-	678	570	390	930	287	250	
				2800	2855	2060	2510	830	240	97	-	678	570	390	930	287	250	
				1400	2555	2500	2950	230	240	97	-	688	470	380	930	287	250	
				2240	2955	2500	2950	550	240	97	-	688	570	380	930	287	250	
				2800	3155	2500	2950	830	240	97	-	688	570	380	930	287	250	
	**	4	X2	1400	2735	3000	3450	230	240	97	-	688	470	380	930	287	250	
				2240	3085	3000	3450	550	240	97	-	688	570	380	930	287	250	
				2800	3325	3000	3450	830	240	97	-	688	570	380	930	287	250	

©DRH4 hoist with cylindrical motor.

N.B.: For the speed, power and dimensions of the wheels see page 18

\* The trolley is made with a single gear motor (motor 100)

\*\* The trolley is made with double gear motor (motor 80)

\*\*\* The trolley is made with double gear motor (motor 100).

# REACTIONS ON THE SUPPORTS

## DRH SERIES ELECTRIC WIRE ROPE HOISTS WITH 2 AND 4 ROPE FALLS IN STANDING OR SUSPENDED EXECUTION

### Two rope fall (2/1) version

HOIST		STATIC HOIST REACTIONS: R1; R2 = daN											
DRH TYPE	CAPACITY (kg)	DRUM C		DRUM N		DRUM L		DRUM X1		DRUM X2			
		R1	R2	R1	R2	R1	R2	R1	R2	R1	R2		
1	800	349	117	373	97	410	69	428	62	442	58		
	1000	425	141	455	115	500	79	520	70	536	64		
	1250	521	170	557	138	611	93	636	80	653	72		
	1600	654	212	699	171	768	111	797	93	817	83		
	2000	806	260	863	207	946	133	981	109	1004	95		
2	1250	555	160	586	136	634	99	662	93	677	88		
	1600	693	197	732	165	792	116	823	107	841	99		
	2000	852	238	898	199	972	136	1007	123	1028	112		
	2500	1050	290	1107	240	1197	161	1237	143	1262	128		
	3200	1327	363	1398	299	1512	196	1560	170	1589	151		
3	2500	1133	347	1193	302	1309	223	1342	203	1373	187		
	3200	1407	423	1482	363	1623	259	1662	233	1699	211		
	4000	1721	509	1812	433	1982	300	2029	266	2073	237		
	5000	2112	618	2224	521	2430	352	2487	308	2539	271		
	6300	2621	759	2760	635	3013	419	3082	363	3146	314		
4	4000	1813	614	1901	543	2097	407	2216	384	2272	353		
	5000	2195	732	2302	642	2536	468	2670	430	2736	389		
	6300	2691	886	2823	771	3109	545	3261	489	3339	436		
	8000	3341	1086	3505	939	3857	647	4032	568	4127	498		
	10000	4104	1323	4308	1136	4738	766	4941	660	5055	570		

### Four rope fall (4/1) version

HOIST		STATIC HOIST REACTIONS: R1; R2 = daN											
DRH TYPE	CAPACITY (kg)	DRUM C		DRUM N		DRUM L		DRUM X1		DRUM X2			
		R1	R2	R1	R2	R1	R2	R1	R2	R1	R2		
1	1600	546	324	617	258	708	176	757	143	787	123		
	2000	671	399	759	316	871	213	929	171	965	145		
	2500	826	494	935	389	1074	260	1145	205	1189	171		
	3200	1046	624	1184	491	1360	324	1447	253	1501	209		
	4000	1296	774	1468	607	1686	398	1792	308	1858	252		
2	2500	847	500	943	409	1078	289	1145	245	1187	213		
	3200	1065	632	1188	514	1358	359	1439	301	1491	259		
	4000	1315	782	1468	634	1678	439	1776	364	1839	311		
	5000	1627	970	1818	784	2078	539	2197	444	2273	377		
	6300	2034	1213	2273	979	2598	669	2743	547	2838	462		
3	5000	1672	1086	1870	900	2172	640	2281	544	2385	465		
	6300	2062	1346	2308	1112	2683	779	2818	657	2945	555		
	8000	2572	1686	2882	1388	3351	961	3520	805	3677	673		
	10000	3172	2086	3558	1712	4137	1175	4346	979	4537	813		
	12500	3922	2586	4403	2117	5118	1444	5378	1197	5613	987		
4	8000	2654	1826	2938	1561	3535	1035	3801	874	3956	744		
	10000	3237	2243	3589	1910	4324	1246	4639	1036	4828	872		
	12500	3966	2764	4403	2346	5310	1510	5686	1239	5919	1031		
	16000	4987	3493	5543	2956	6690	1880	7153	1522	7445	1255		
	20000	6154	4326	6845	3654	8268	2302	8828	1847	9190	1510		
25000	7645	5363	8502	4521	10261	2837	10944	2259	11391	1837			

## DRH SERIES ELECTRIC ROPE HOISTS WITH 6 AND 8 ROPE FALLS IN STANDING EXECUTION

### Six rope fall (6/1) version

HOIST		STATIC HOIST REACTIONS: R1; R2 = daN							
DRH TYPE	CAPACITY (kg)	DRUM N		DRUM L		DRUM X1		DRUM X2	
		R1	R2	R1	R2	R1	R2	R1	R2
3	16000	6415	1883	7179	1161	7385	970	7573	807
	20000	7968	2329	8917	1423	9172	1183	9403	977
4	25000	10246	2788	11321	1784	11758	1451	12033	1202
	32000	13015	3519	14378	2227	14918	1791	15266	1469

### Eight rope fall (8/1) version

HOIST		STATIC HOIST REACTIONS: R1; R2 = daN							
DRH TYPE	CAPACITY (kg)	DRUM N		DRUM L		DRUM X1		DRUM X2	
		R1	R2	R1	R2	R1	R2	R1	R2
3	20000	-	-	8400	1950	8750	1615	9050	1340
	25000	-	-	10501	2349	10929	1936	11310	1580
4	40000	13920	6635	16506	4118	17484	3245	18139	2616
	50000	17307	8247	20529	5096	21734	3996	22548	3207

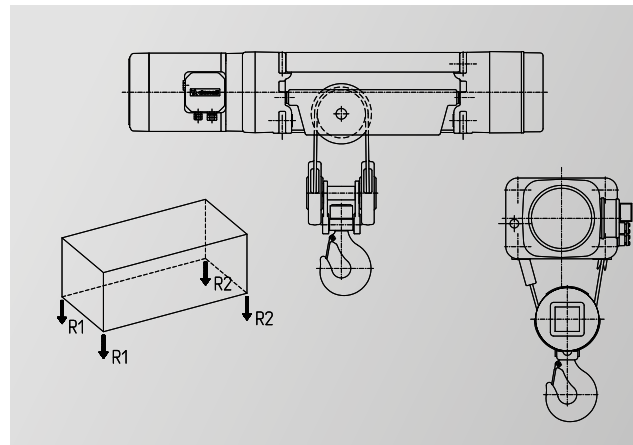

**DST/N/S MONORAIL TROLLEYS FOR DRH ELECTRIC WIRE ROPE HOISTS – 2 (2/1) FALL VERSION**

HOIST		STATIC HOIST REACTIONS: R1; R2 = daN									
DRH TYPE	CAPACITY (kg)	DRUM C		DRUM N		DRUM L		DRUM X1		DRUM X2	
		R1	R2	R1	R2	R1	R2	R1	R2	R1	R2
1	800	377	131	400	110	437	83	445	90	450	95
	1000	453	155	481	129	527	93	535	100	541	104
	1250	549	184	583	152	638	107	646	114	658	112
	1600	682	226	726	184	795	125	804	131	822	123
	2000	834	274	889	221	973	147	988	147	1010	135
2	1250	581	174	611	149	661	112	668	120	673	125
	1600	720	210	757	178	819	129	826	136	834	139
	2000	878	252	923	212	999	149	1006	156	1020	153
	2500	1076	304	1132	253	1224	174	1232	180	1255	168
	3200	1353	377	1423	312	1539	209	1554	209	1581	192
3	2500	1171	367	1230	320	1346	242	1367	258	1387	275
	3200	1445	443	1519	381	1660	278	1680	295	1700	312
	4000	1759	529	1849	451	2019	319	2040	335	2072	341
	5000	2150	638	2261	539	2467	371	2490	385	2538	375
	6300	2660	778	2797	653	3050	438	3073	452	3145	418
4	4000	1901	659	1990	588	2184	451	2242	498	2268	557
	5000	2283	777	2391	687	2624	511	2680	560	2731	594
	6300	2780	930	2913	815	3196	589	3250	640	3334	641
	8000	3429	1131	3595	983	3944	691	4002	738	4123	702
	10000	4193	1367	4397	1181	4825	810	4910	830	5050	775

**DST/N/S MONORAIL TROLLEYS FOR DRH ELECTRIC WIRE ROPE HOISTS – 4 (4/1) FALL VERSION**

HOIST		STATIC HOIST REACTIONS: R1; R2 = daN									
DRH TYPE	CAPACITY (kg)	DRUM C		DRUM N		DRUM L		DRUM X1		DRUM X2	
		R1	R2	R1	R2	R1	R2	R1	R2	R1	R2
1	1600	573	337	644	271	735	190	760	180	788	162
	2000	698	412	785	330	898	227	933	207	967	183
	2500	855	505	963	402	1102	273	1148	242	1190	210
	3200	1073	637	1211	504	1387	338	1450	290	1502	248
	4000	1323	787	1494	621	1713	412	1795	345	1860	290
2	2500	881	519	978	427	1112	306	1146	294	1186	264
	3200	1100	650	1223	532	1392	376	1441	349	1490	310
	4000	1350	800	1503	652	1712	456	1777	413	1838	362
	5000	1663	987	1853	802	2112	556	2198	492	2273	427
	6300	2069	1231	2308	997	2632	686	2745	595	2838	512
3	5000	1758	1130	1959	946	2258	682	2313	685	2420	615
	6300	2148	1390	2398	1157	2768	822	2850	798	2980	705
	8000	2658	1730	2973	1432	3436	1004	3552	946	3710	825
	10000	3258	2130	3648	1757	4222	1218	4377	1121	4572	963
	12500	4008	2630	4493	2162	5204	1486	5410	1338	5648	1137
4	8000	2805	1903	3090	1638	3685	1110	3801	1099	3982	1003
	10000	3389	2319	3741	1987	4474	1321	4639	1261	4855	1130
	12500	4118	2840	4555	2423	5460	1585	5686	1464	5945	1290
	16000	5139	3569	5695	3033	6840	1955	7152	1748	7471	1514
	20000	6305	4403	6997	3731	8417	2378	8828	2072	9216	1769

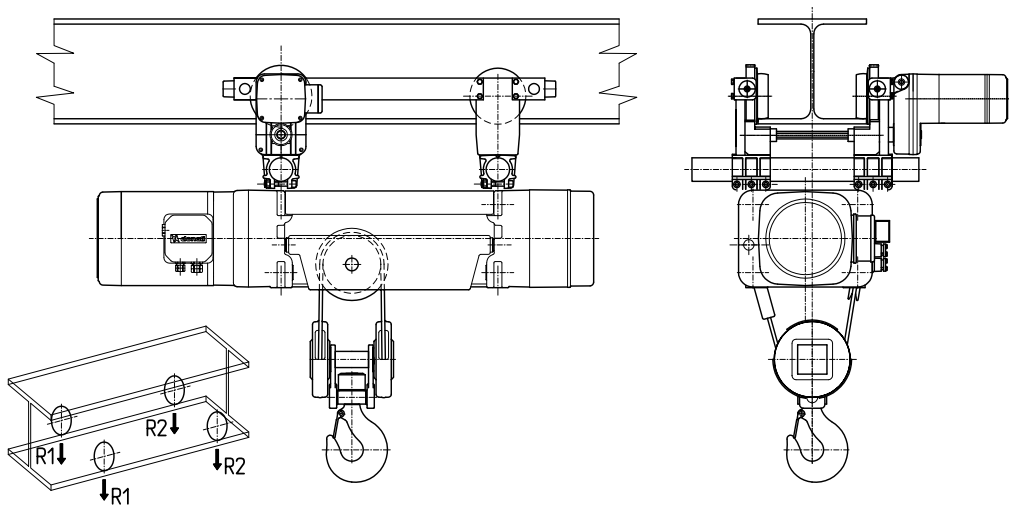

**DST/R MONORAIL TROLLEYS FOR DRH ELECTRIC WIRE ROPE HOISTS – 2 (2/1) FALL VERSION**

HOIST		STATIC HOIST REACTIONS: R1; R2 = daN											
DRH TYPE	CAPACITY (kg)	DRUM C		DRUM N		DRUM L		DRUM X1		DRUM X2			
		R1	R2	R1	R2	R1	R2	R1	R2	R1	R2		
1	800	392	138	416	119	451	89	475	105	482	113		
	1000	468	162	498	137	540	100	565	115	572	123		
	1250	563	192	600	160	652	113	675	130	684	136		
	1600	697	233	742	193	808	132	830	150	847	148		
	2000	849	281	906	229	987	153	1010	170	1035	160		
2	1250	615	190	644	166	695	128	710	145	716	154		
	1600	753	227	790	195	852	146	870	160	877	168		
	2000	912	268	957	228	1032	166	1050	180	1057	188		
	2500	1110	320	1165	270	1257	191	1275	205	1290	205		
	3200	1387	393	1457	328	1572	226	1588	242	1617	228		
3	2500	1226	394	1287	348	1411	274	1470	310	1495	335		
	3200	1500	470	1576	409	1725	310	1780	350	1805	375		
	4000	1813	557	1905	480	2084	351	2140	390	2165	415		
	5000	2205	665	2317	568	2532	403	2590	440	2622	458		
	6300	2714	806	2853	682	3115	470	3170	510	3228	502		
4	4000	2031	724	2121	654	2327	523	2450	610	2510	665		
	5000	2413	842	2522	753	2767	583	2890	670	2950	725		
	6300	2910	995	3044	881	3340	660	3460	750	3510	815		
	8000	3559	1196	3726	1049	4088	762	4210	850	4298	877		
	10000	4323	1432	4528	1247	4968	882	5090	970	5225	950		

**DST/R MONORAIL TROLLEYS FOR DRH ELECTRIC WIRE ROPE HOISTS – 4 (4/1) FALL VERSION**

HOIST		STATIC HOIST REACTIONS: R1; R2 = daN											
DRH TYPE	CAPACITY (kg)	DRUM C		DRUM N		DRUM L		DRUM X1		DRUM X2			
		R1	R2	R1	R2	R1	R2	R1	R2	R1	R2		
1	1600	590	345	660	280	748	197	782	203	813	187		
	2000	715	420	802	338	911	234	955	230	992	208		
	2500	871	514	979	411	1115	280	1170	265	1215	235		
	3200	1090	645	1227	513	1400	345	1472	313	1527	273		
	4000	1340	795	1511	629	1726	419	1818	367	1884	316		
2	2500	920	538	1017	446	1150	325	1184	331	1226	304		
	3200	1139	669	1262	551	1430	395	1478	387	1530	350		
	4000	1389	819	1542	671	1750	475	1815	450	1878	402		
	5000	1701	1007	1892	821	2150	575	2235	530	2313	467		
	6300	2107	1251	2347	1016	2670	705	2782	633	2878	552		
3	5000	1829	1164	2024	979	2336	722	2400	773	2513	710		
	6300	2219	1424	2464	1189	2847	861	2938	885	3072	800		
	8000	2729	1764	3038	1465	3515	1043	3640	1033	3804	919		
	10000	3329	2164	3714	1789	4300	1258	4465	1208	4665	1058		
	12500	4079	2664	4558	2195	5283	1525	5497	1425	5741	1232		
4	8000	2960	1980	3248	1717	3862	1198	3986	1284	4180	1203		
	10000	3543	2397	3899	2066	4650	1410	4824	1446	5052	1330		
	12500	4273	2917	4713	2502	5636	1674	5871	1649	6143	1490		
	16000	5293	3647	5853	3112	7017	2043	7338	1932	7670	1713		
	20000	6460	4480	7155	3810	8594	2466	9013	2257	9414	1968		

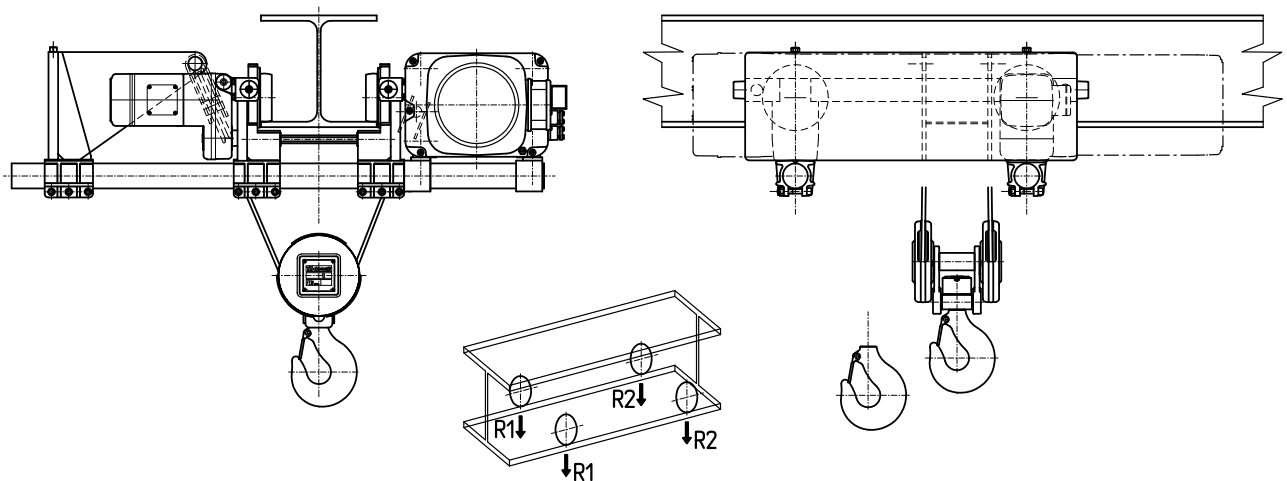

## DRT DOUBLE GIRDER TROLLEYS FOR DRH STANDING/SUSPENDED ELECTRIC ROPE HOISTS - 2 FALL (2/1) AND 4 FALL (4/1) VERSIONS

### Two rope fall (2/1) version

HOIST		STATIC HOIST REACTIONS: R1; R2 = daN											
DRH TYPE	CAPACITY (kg)	DRUM C		DRUM N		DRUM L		DRUM X1		DRUM X2			
		R1	R2	R1	R2	R1	R2	R1	R2	R1	R2		
1	800	335	179	369	162	404	131	430	113	457	101		
	1000	400	214	428	193	482	153	514	129	545	113		
	1250	481	258	515	231	580	180	618	150	654	129		
	1600	594	320	637	284	718	217	765	178	808	150		
	2000	724	390	776	345	875	260	932	211	984	174		
2	1250	529	236	562	211	626	164	662	151	676	142		
	1600	651	289	691	257	770	196	801	177	829	164		
	2000	791	349	839	309	935	230	972	206	1004	189		
	2500	955	425	1025	373	1142	273	1185	243	1223	220		
	3200	1209	531	1284	464	1430	335	1484	294	1530	263		
3	2500	1084	496	1146	449	1295	365	1368	340	1419	316		
	3200	1326	604	1403	542	1583	417	1666	392	1726	369		
	4000	1602	728	1696	649	1912	488	2006	452	2077	408		
	5000	1948	882	2063	782	2323	577	2432	526	2515	470		
	6300	2397	1083	2539	956	2858	692	2984	624	3085	550		
4	4000	1737	831	1825	763	2064	611	2218	585	2340	558		
	5000	2077	991	2184	904	2467	708	2639	664	2776	622		
	6300	2518	1200	2649	1089	2991	834	3186	767	3342	706		
	8000	3096	1472	3259	1329	3677	998	3902	901	4082	816		
	10000	3775	1793	3975	1613	4484	1191	4743	1606	4953	945		

### Four rope fall (4/1) version

HOIST		STATIC HOIST REACTIONS: R1; R2 = daN											
DRH TYPE	CAPACITY (kg)	DRUM C		DRUM N		DRUM L		DRUM X1		DRUM X2			
		R1	R2	R1	R2	R1	R2	R1	R2	R1	R2		
1	1600	535	383	587	338	675	265	734	219	783	186		
	2000	649	469	713	412	821	319	892	261	960	218		
	2500	792	576	870	505	1003	387	1090	313	1161	257		
	3200	992	726	1090	635	1258	482	1366	387	1454	314		
	4000	1220	898	1342	783	1549	591	1682	471	1790	378		
2	2500	830	568	908	495	1047	378	1109	329	1159	294		
	3200	1034	714	1133	620	1307	468	1384	404	1446	357		
	4000	1268	880	1391	762	1605	570	1699	489	1774	429		
	5000	1560	1088	1713	940	1977	698	2092	596	2183	520		
	6300	1940	1368	2133	1170	2460	866	2603	735	2716	637		
3	5000	1668	1200	1815	1060	2117	813	2251	722	2368	632		
	6300	2026	1482	2223	1302	2593	987	2755	868	2897	753		
	8000	2508	1850	2755	1620	3216	1214	3413	1060	3589	911		
	10000	3076	2282	3381	1994	3948	1482	4187	1286	4403	1097		
	12500	3785	2823	4164	2461	4863	1817	5155	1568	5420	1330		
4	8000	2640	1980	2862	1781	3425	1315	3683	1145	3907	1016		
	10000	3196	2424	3470	2173	4158	1582	4466	1362	4730	1193		
	12500	3892	2978	4230	2663	5074	1916	5444	1634	5758	1415		
	16000	4866	3754	5295	3348	6357	2383	6814	2014	7198	1725		
	20000	5979	4641	6512	4131	7823	2917	8380	2448	8844	2079		
	*25000	7426	5777	8088	5138	9720	3616	10410	3028	10990	2565		

\*Version only supported

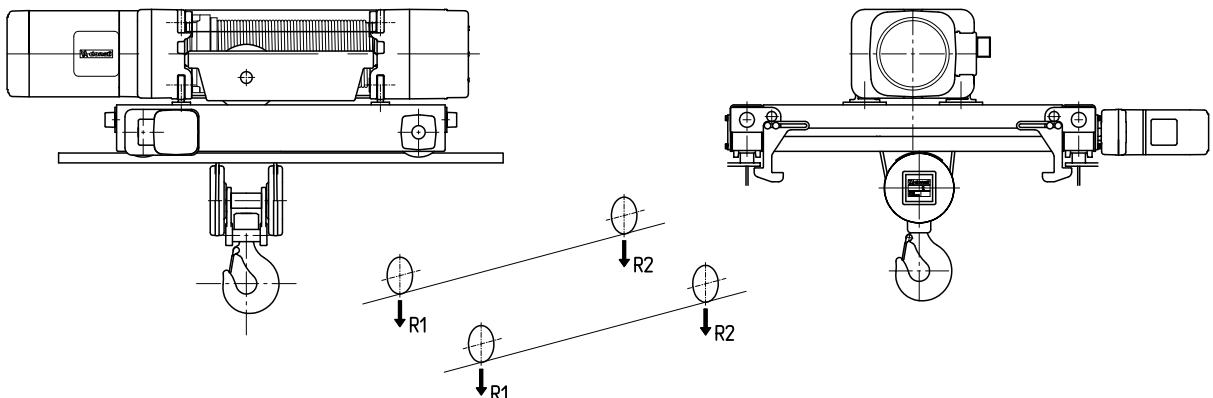



**DRT DOUBLE GIRDER TROLLEYS FOR DRH ELECTRIC WIRE ROPE HOISTS – TRANSVERSAL 2 FALL (2/1) AND 4 FALL (4/1) VERSIONS**

**Two rope fall (2/1) version**

HOIST		STATIC HOIST REACTIONS: R1; R2 = daN					
DRH TYPE	CAPACITY (kg)	DRUM C		DRUM N		DRUM L	
		R1	R2	R1	R2	R1	R2
1	800	305	199	313	194	405	125
	1000	364	240	374	233	484	146
	1250	438	291	450	282	584	171
	1600	541	363	555	352	723	207
	2000	659	445	676	431	882	248
2	1250	482	273	494	264	577	211
	1600	593	337	607	326	709	254
	2000	720	410	737	396	859	304
	2500	878	502	899	484	1046	367
	3200	1100	630	1125	608	1309	454
3	2500	1046	507	1084	479	1266	369
	3200	1282	621	1329	584	1548	437
	4000	1552	751	1609	704	1871	514
	5000	1890	913	1959	854	2275	610
	6300	2328	1125	2414	1049	2800	735
4	4000	1802	741	1810	755	-	-
	5000	2162	881	2168	897	-	-
	6300	2630	1063	2634	1081	-	-
	8000	3242	1301	3243	1322	-	-
	10000	3962	1581	3960	1605	-	-

**Four rope fall (4/1) version**

HOIST		STATIC HOIST REACTIONS: R1; R2 = daN					
DRH TYPE	CAPACITY (kg)	DRUM C		DRUM N		DRUM L	
		R1	R2	R1	R2	R1	R2
1	1600	500	408	515	398	670	265
	2000	607	501	625	488	815	320
	2500	741	617	763	600	996	389
	3200	928	780	955	758	1250	485
	4000	1142	966	1175	938	1540	595
2	2500	783	605	805	588	949	474
	3200	977	761	1004	739	1182	591
	4000	1198	940	1231	912	1449	724
	5000	1475	1163	1515	1128	1782	891
	6300	1834	1454	1885	1408	2215	1108
3	5000	1633	1197	1704	1139	2045	870
	6300	2000	1480	2087	1406	2504	1061
	8000	2480	1850	2589	1754	3105	1310
	10000	3045	2285	3179	2164	3812	1603
	12500	3752	2828	3916	2677	4696	1969
4	8000	2757	1838	2847	1773	-	-
	10000	3347	2248	3455	2165	-	-
	12500	4085	2760	4215	2655	-	-
	16000	5117	3478	5280	3340	-	-
	20000	6297	4298	6497	4123	-	-

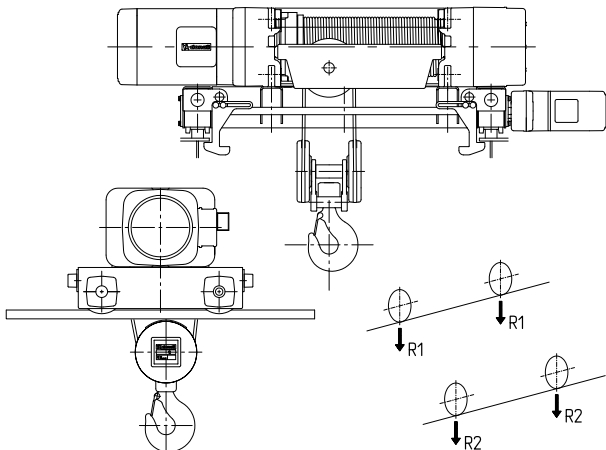

**DRT DOUBLE GIRDER TROLLEYS FOR DRH ELECTRIC WIRE ROPE TROLLEYS – 6 FALL (6/1) AND 8 FALL (8/1) VERSIONS**

**Six rope fall (6/1) version**

GAUGE TROLLEY S (mm)	CAPACITY (kg)	STATIC HOIST REACTIONS: R1; R2 = daN							
		DRUM N		DRUM L		DRUM X1		DRUM X2	
		R1	R2	R1	R2	R1	R2	R1	R2
1200	16000	5360	3200	6210	2435	6620	2070	6970	1785
	20000	6610	3950	7655	2990	8160	2530	8587	2168
1400	16000	5367	3203	6214	2441	6627	2073	6997	1788
	20000	6615	3955	7660	3000	8170	2530	8600	2170
	25000	8250	5150	9600	3900	10250	3375	10838	2857
	32000	10400	6500	12100	4900	12980	4150	13650	3545
2240	25000	8350	5200	9700	3950	10350	3400	10925	2900
	32000	10500	6550	12200	4950	13050	4200	13737	3588
2800	25000	8450	5250	9800	4050	10400	3500	11025	2950
	32000	10600	6600	12300	5050	13100	4300	13837	3638

**Eight rope fall (8/1) version**

GAUGE TROLLEY S (mm)	CAPACITY (kg)	STATIC HOIST REACTIONS: R1; R2 = daN							
		DRUM N		DRUM L		DRUM X1		DRUM X2	
		R1	R2	R1	R2	R1	R2	R1	R2
1400	25000	-	-	9085	4115	9780	3460	10380	2910
	40000	11500	9500	13850	7300	14900	6350	16325	5043
	50000	14400	11600	17550	8600	18950	7300	20150	6200
2240	25000	-	-	9159	4081	9845	3435	10437	1938
	40000	11600	9600	13950	7350	15050	6400	16442	5101
2800	50000	14340	11860	17280	9020	18590	7860	20295	6248
	25000	-	-	9242	4123	9932	3478	10504	2971
2800	40000	11650	9650	14000	7400	15100	6450	16522	5141
	50000	14400	11900	17340	9060	18660	7890	20375	6288

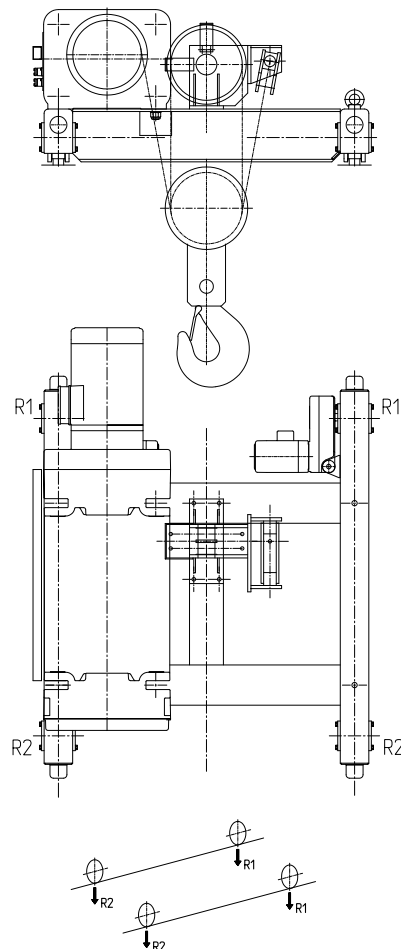

**TABLE  $\Phi$  DRUM AND SHEAVE PITCH DIAMETER**

DHR TYPE	$\Phi$ ROPE (mm)	$\Phi$ DRUM PITCH DIAMETER (mm)	$\Phi$ SHEAVE PITCH DIAMETER (mm)
1	7	159	157
2	8	193	180
	9	194	181
3	12	242	269
	13	243	270
4	15	323	337
	16	324	338

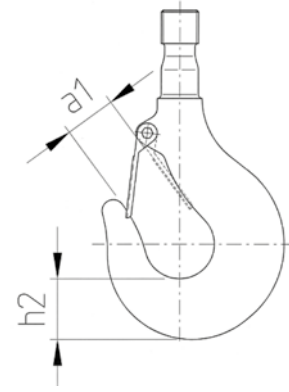

**TABLE OF HOOKS FOR DRH**

DRH SIZE	N° FALLS	TYPE OF HOOK IN RELATION TO THE CAPACITY (kg) AND FEM SERVICE GROUP								HOOK DIMENSIONS DIMENSIONS (mm)		
		FEM 1Bm		FEM 1Am		FEM 2m		FEM 3m		a1	h2	
		CAPACITY	TYPE N°	CAPACITY	TYPE N°	CAPACITY	TYPE N°	CAPACITY	TYPE N°			
1	2/1	-	-	1250	-	1000	-	800	-	33	37	
		-	-	1600	08V	1250	08V	1000	08V			
		-	-	2000	-	1600	-	1250	-			
	4/1	-	-	-	1600	-	1250	-	1000	-	38	48
		3200	1.6V	2500	1.6V	2000	1.6V	1600	1.6V			
		-	-	3200	-	2500	-	2000	-			
2	2/1	-	-	1600	-	1250	-	1000	-	38	48	
		-	-	2000	1.6V	1600	1.6V	1250	1.6V			
		-	-	2500	-	2000	-	1600	-			
	4/1	-	-	-	3200	-	2500	-	2000	-	43	58
		5000	2.5T	4000	2.5T	3200	2.5T	2500	2.5T			
		-	-	5000	-	4000	-	3200	-			
3	2/1	-	-	2500	-	2000	-	1600	-	43	58	
		-	-	3200	2.5T	2500	2.5T	2000	2.5T			
		-	-	4000	-	3200	-	2500	-			
	4/1	-	-	-	5000	-	4000	-	3200	-	50	75
		10000	5T	8000	5T	6300	5T	5000	5T			
		-	-	10000	-	8000	-	6300	-			
4	2/1	-	-	12500	-	10000	-	8000	-	77	106	
		-	-	20000	10S	16000	10S	-	-			
		-	-	25000	10S	20000	10S	-	-			
	4/1	-	-	-	5000	-	4000	-	3200	-	77	106
		-	-	6300	5T	5000	5T	4000	5T			
		-	-	8000	-	6300	-	5000	-			
6/1	-	-	-	10000	-	8000	-	6300	-	87	118	
	-	-	10000	10P	10000	10P	8000	10P				
	16000	10P	12500	10P	10000	10P	10000	10P				
8/1	-	-	-	20000	-	16000	-	12500	-	87	118	
	-	-	25000	10T	20000	10T	-	-				
	25000	10T	25000	10T	20000	10T	-	-				
8/1	-	-	-	32000	-	25000	-	-	-	87	118	
	-	-	-	12T	32000	12T	-	-				
	50000	12T	40000	12T	-	-	-	-				
						40000	12V	-	-			

## SPECIFICATIONS OF MOTORS, FUSES AND POWER CABLES

DRH HOIST	MOTOR TYPE	POLES	INSTALLED POWER ( kW )	COS $\varphi$	I <sub>a</sub> - ( A ) 400V - 50Hz	I <sub>n</sub> - ( A ) 400V - 50Hz	LINE FUSE ( A ) 400V - 50Hz	MINIMUM POWER CABLE SECTION 400V - ( $\Delta$ U20V )	
								$\Phi$ mm <sup>2</sup>	L =m
1	112K4R	4	3	0.75	40	8	16	2.5	≤ 30
	112K5R	4/12	3/1	0.72/0.5	38/13	8/6.6	16	2.5	≤ 30
2	132K4R	4	5	0.75	58	12	20	4	≤ 30
	132K5R	4/12	5/1.65	0.78/0.5	50/17	12/10	20	4	≤ 30
3	160K4R	4	10	0.8	110	22	32	6	≤ 30
	160K5R	4/12	10/3.3	0.77/0.46	100/20	24/18	32	6	≤ 30
4	180K4R	4	16	0.82	175	34	63	10	≤ 20
	180K5R	4/12	16/5.3	0.78/0.46	170/55	38/25	63	10	≤ 20
4 Cilindrico	180C4R	4	24	0.88	330	48	80	16	≤ 20
	180C5R	4/12	24/7.8	0.88/0.5	330/80	48/32	80	16	≤ 20

TROLLEY DST / DRT	MOTOR TYPE	POLES	INSTALLED POWER ( kW )	COS $\varphi$	I <sub>a</sub> - ( A ) 400V - 50Hz	I <sub>n</sub> - ( A ) 400V - 50Hz
DST1 DST2 DRT1	71K3P	2/8	0.4/0.09	0.75/0.6	4.4/1.2	1.2/0.9
	71C2P	2	0.32	0.72	6	1.0
	71C4P	4	0.16	0.5	4	1.0
	71K2PI	2 Inverter	0.5	0.72	5.2	1.3
DST3 DRT2	80K3P	2/8	0.5/0.12	0.85/0.6	5.5/1.6	1.3/1.1
	80K2PL	2	0.63	0.75	7.7	1.7
	80K4PL	4	0.32	0.65	3.9	1.1
	80K2PI	2 Inverter	0.8	0.8	9.7	1.9
DST4 * DRT3	80K3PL	2/8	0.63/0.15	0.82/0.57	6.8/1.9	1.6/1.3
	80K2PL	2	0.63	0.75	7.7	1.7
	80K4PL	4	0.32	0.65	3.9	1.1
	80K2PI	2 Inverter	0.8	0.8	9.7	1.9
** DRT3 *** DRT4	100K3P	2/8	1.25/0.31	0.84/0.6	16/3.6	3.1/1.8
	100K2P	2	1.25	0.83	16	2.9
	100K4P	4	0.63	0.8	8.5	1.7
	100K2PI	2 Inverter	2.0	0.86	23	4.3

- The DST trolleys articulated version are made with double gear motor. Thus the powers shown in the table need to be doubled.

\* The DRT3 trolley for DRH4 hoists with 6 falls is made with double traverse gear motor.  
The DRT3 trolley for DRH3 hoists with 8 falls (frame gauge 2240-2800) is made with double traverse gear motor.  
Thus the powers shown in the table need to be doubled.

\*\* The DRT3 trolley for DRH4 hoists with 4 falls, DRH3 with 6 falls (frame gauge 1200-1400) and DRH3 with 8 falls (frame gauge 1400) is made with single traverse gear motor.

\*\*\* The DRT4 trolley for DRH4 hoists with 8 falls is made with double traverse gear motor. Thus the powers shown in the table need to be doubled.



## **Donati Sollevamenti S.r.l.**

Via Quasimodo, 17  
20025 Legnano (MI) – Italy  
T +39 0331 14811  
F +39 0331 1481880  
E dvo.info@donaticranes.com

KMAN02CG00

### **Factory:**

Via Archimede, 52  
20864 Agrate Brianza (MB) – Italy

**[www.donaticranes.com](http://www.donaticranes.com)**

