

USE INSTRUCTIONS

INSTALLATION | USE | MAINTENANCE

**JIB CRANE MANUAL AND
ELECTRIC ROTATION**
PILLAR: GBA-CBE Series
WALL: GBP-MBE Series



INDEX

1. PRELIMINARY INFORMATION	4
1.1 Contents and use of the manual	4
1.2 Symbols: meaning and use	4
1.3 Collaboration with the user	5
1.4 Regulatory compliance	5
1.5 Manufacturer's responsibility and warranty	5
2. DESCRIPTION OF THE MACHINE AND TECHNICAL INFORMATION	6
2.1 The jib cranes with manual/electric rotation	6
2.1.1 Intended use - Expected use - Intended purpose	6
2.1.2 Installation restrictions	6
2.1.3 Composition of jib cranes	6
2.1.4 Maintenance of CBE rotation motor reducer	9
2.2 Technical information and service conditions	10
2.2.1 Regulatory reference framework	10
2.2.2 Protection and insulation of electrical parts	10
2.2.3 Electrical supply	10
2.2.4 Ambient use conditions	10
2.2.5 Noise - Vibration	10
2.2.6 Use criteria and operating conditions	11
2.2.7 GBA-GBP Series - Manual rotation jib cranes: characteristics and technical data	12
2.2.8 CBE-MBE Series - Electrical rotation jib cranes: characteristics and technical data	15
2.2.9 GBA/GBP and CBE/MBE: Fixing systems for jib cranes	17
3. SAFETY AND ACCIDENT PREVENTION	19
3.1 Authorised operator qualifications	19
3.2 General safety regulations	20
3.3 Safety symbols	20
3.4 Warnings on residual risks	21
3.5 Safety devices and instructions	22
3.5.1 Control devices	22
3.5.2 Safety and emergency devices for GBA- GBP	22
3.5.3 Safety and emergency devices for CBE e MBE	23
3.5.4 Warning and notice devices - Signage summary	24
4. HANDLING - INSTALLATION - COMMISSIONING	25
4.1 General notes for delivery	25
4.2 Packaging, transport and handling	26
4.2.1 Standard packaging	26
4.2.2 Transport	27
4.2.3 Handling	27
4.2.4 Removal of the packaging and/or checking of the crane parts	28
4.3 Jib crane installation	29

4.3.1	Installer duties and responsibilities	29
4.3.2	Preparation of the installation site	30
4.3.3	GBA – CBE: Assembly of the pillar (foundation plate, counterplate, pillar)	31
4.3.4	GBP – MBE: Assembly of the bracket (stir-ups, bracket)	36
4.3.5	GBA/CBE – GBP/MBE: Assembly of the arm	39
4.3.6	S profiles channel arm	40
4.3.7	Mounting of the trolley block inside the S profile channel arm	41
4.3.8	Assembly of the electric system with the connector block	42
4.3.8.1	<i>Commissioning of the rotation limit switch</i>	45
4.3.9	Assembly of the trolley/hoist	46
4.3.9.1	<i>Assemble of trolley/hoist on the profile S channel arm crane S</i>	47
4.3.10	Rotation stops for booms on GBA and GBP	48
4.4	Commissioning	51
4.4.1	Preliminary operations - Adjustments and test runs	51
4.4.2	Acceptance test of the jib crane - Suitability for use	52
4.5	Messa fuori servizio	54
4.5.1	Storage and preservation of parts	54
4.5.2	Resetting after storage	54
5.	OPERATION AND USE OF THE JIB CRANE	56
5.1	Functions of the jib crane	56
5.1.1	Intended use - Expected use - Intended purpose	56
5.1.2	Permitted loads, unpermitted loads	57
5.1.3	Lifting accessories	57
5.2	Operating conditions	58
5.2.1	Operating environment	58
5.2.2	Danger zones and exposed persons	58
5.2.3	Work area lighting	59
5.2.4	Operator	59
5.2.5	Jib crane capacity	60
5.2.6	Manoeuvres: lifting, trolley traverse and arm rotation	60
5.2.7	Safety devices	61
5.3	Activating the jib crane	62
5.4	Deactivating at the end of work	62
5.5	Usage criteria and precautions	63
5.6	Use contraindications	64
5.6.1	Unintended and unpermitted use - Predictable and unpredictable incorrect use	65
6.	JIB CRANE MAINTENANCE	67
6.1	Safety precautionary measures	67
6.2	Qualification of personnel assigned to maintenance	69
6.3	Maintenance plan	74
6.3.1	Daily and routine maintenance	74

6.3.2	Frequency and deadlines for maintenance interventions	75
6.3.3	Test of part and component efficiency	76
6.3.4	Cleaning and lubricating the jib crane	79
6.4	Adjusting and regulating	80
6.4.1	Adjusting the rotation brake of the crane arm	80
6.5	Troubleshooting	81
6.5.1	Main causes of malfunctions or faults and possible solutions	81
6.5.2	Personnel authorised to intervene in the event of a failure	81
6.5.3	Decommissioning	81
6.6	Disassembly, disposal and scrapping	81
7. SPARE PARTS		82
8. CONTROL BOOKLET		100

1. PRELIMINARY INFORMATION

1.1 CONTENTS AND USE OF THE MANUAL

This technical publication, identified by the code **KMAN55MG00**, refers to “Jib cranes, manually/electric rotated, in **GBA-CBE** series pillar-mounted model or **GBP-MBE** series wall-mounted model”, built and put on the market by the company:



DONATI SOLLEVAMENTI S.r.l.

Via Quasimodo, 17 - 20025 Legnano (MI)
Tel. +39 0331 14811 - Fax +39 0331 1481880
E-mail: dvo.info@donaticranes.com
www.donaticranes.com

It refers to their “intended use”, to their technical functional and performance characteristics and to the relevant installation, use and maintenance instructions. It is intended for:

- ▶ the supervisor of the factory, workshop, building site
- ▶ the staff in charge of transporting, handling and installation of the equipment
- ▶ the operators of the jib crane
- ▶ the maintenance staff

This manual must be kept by the person in charge of the above mentioned duties in a suitable place, so that it is always available for consultation and kept in the best possible state.





If the manual is lost or becomes unusable, replacement documentation should be requested directly from the manufacturer by quoting the code of this manual.



The manufacturer retains the material and intellectual rights of this publication and forbids the divulgation and duplication, even partial, without prior written permission.

1.2 SYMBOLS: MEANING AND USE

Certain symbols are used in this manual to call the reader’s attention and underline some particularly important aspects. The following table shows the list and meaning of the symbols used in the manual.

SYMBOL	MEANING	EXPLANATION, ADVICE, NOTES
	Hazard	<ul style="list-style-type: none"> ▶ Indicates a hazard with the risk of an accident, including fatal. ▶ The failure to comply with the instructions marked with this symbol may result in a seriously hazardous situation for the operator’s and/or exposed persons’ safety! ▶ Carefully follow the instructions!
	Warning	<ul style="list-style-type: none"> ▶ Represents a warning note of a possible deterioration of the jib or a personal item of the operator. ▶ Important warning to pay attention to.
	Warning Note	<ul style="list-style-type: none"> ▶ Indicates a warning or a note on key functions or useful information.
	Visual observation Actions to perform	<ul style="list-style-type: none"> ▶ A stylized eye may indicate to the operator that: <ul style="list-style-type: none"> a) He/she needs to make a visual inspection. b) He/she must proceed with the operating sequence. c) A measurement value needs to be read, a warning needs to be checked, etc

1.3 COLLABORATION WITH THE USER

The manual reflects the state of the art at the time the machine was placed on the market and is an integral part of the machine.

Any supplements to the manual that the manufacturer considers appropriate to send to the users must be kept together with the manual.

The manufacturer is available to its customers to provide additional information and to consider proposals for improvement in order to make the manual closer to the needs for which it was prepared.

If the jib crane is sold, the main user is asked to deliver, along with the crane, this manual and the relative attached documentation (declarations, diagrams, test logbook, etc.).

1.4 REGULATORY COMPLIANCE

GBA-CBE-GBP-MBE jib cranes are designed and produced following the “**Essential Safety Requirements**” of **Attachment I of the Community Directive 2006/42/CE** the crane can be put on the market with **CE Mark** and the **EC Declaration of Conformity - Attachment II A**.

In addition, GBA-CBE-GBP-MBE jib cranes are in compliance with the following directives:

- ▶ **Low Voltage Directive 2014/35/EU;**
- ▶ **Electromagnetic compatibility directive 2014/30/EU.**



fig.1

1.5 MANUFACTURER'S RESPONSIBILITY AND WARRANTY

In terms of the contents of this manual the company shall not be held **liable** in the following cases:

- ▶ use of the jib crane not in compliance with national laws on safety and accident prevention
- ▶ incorrect selection or set-up of structures on which the crane will be installed
- ▶ defects in voltage and the mains supply
- ▶ no or incorrect compliance with the instructions provided in this manual
- ▶ unauthorised modifications to the machine
- ▶ use by personnel who are not trained or not suitable

To be able to use the **warranty**, the customer must scrupulously follow the instructions indicated in this manual, and in particular:

- ▶ always operate within the limits of use of the jib crane
- ▶ always perform a constant and diligent maintenance
- ▶ assign use of the machine to operators with a proven capacity, adequately instructed for the purpose
- ▶ only use the original spare parts indicated by the manufacturer



- ▶ **The intended use and the configurations of the jib are the only ones allowed. Do not try to use it ignoring the provided instructions.**
- ▶ **The instructions contained in this manual do not replace but summarise the obligations to comply with current accident prevention laws.**

2. DESCRIPTION OF THE MACHINE AND TECHNICAL INFORMATION

2.1 THE JIB CRANES WITH MANUAL/ELECTRIC ROTATION

2.1.1 INTENDED USE - EXPECTED USE - INTENDED PURPOSE

The **jib cranes**, manually/electric rotated, in GBA-CBE series pillar-mounted model or GBP-MBE series wall-mounted model, are produced to move goods within the plant.

Jib cranes have three functions:

- ▶ **they lift** the load vertically in space, via a hook on the lifting unit, generally composed of a manual or electric chain hoist and using accessories suitable for this operation;
- ▶ **they traverse** the load in space, with the assistance of an electric or manual hoist holder trolley, which runs along the radial axis of the crane arm;
- ▶ **they rotate** the load in space, around the constrained axis of the arm, through a manual push action of the load using the circular area below, limited by the rotation radius of the arm.

2.1.2 INSTALLATION RESTRICTIONS

The **GBA-CBE pillar-mounted jib cranes** are intended to be fixed to the ground, the pillar is self-supporting and can be fixed to the ground using log bolts, on a foundation plinth or in special cases having checked suitability, also with screw anchors or dowelling.

The **GBP-MBE wall-mounted jib cranes** are intended to be fixed to an existing structure (pillars, walls, machine casing, etc), using a system of brackets and staybolts, either with fixing screws or, subject to a check, with screw anchors or dowelling.



In both cases (pillar-mounted and wall-mounted cranes) the user MUST check, directly or using specialised staff, the suitability of the surfaces to be fixed on. These surfaces must guarantee the stability and safety of the crane in all its working conditions, supporting the lifting operations and the dynamic effects of the tilting momentum and of the type and speed of lifting.

2.1.3 COMPOSITION OF JIB CRANES

The composition of the jib crane is relatively simple, both in the pillar-mounted version and the wall-mounted one. Both have a steel structure, the lifting block made up of a chain hoist (electric or manual), the translation unit formed by a hoist-carrying trolley (electric or push-trolley), a series of accessories (support brackets, staybolts, foundation plinth, electric unit, etc.).

The **GBA-CBE pillar-mounted** jib crane consists of a tubular pillar with polygonal section fixed using log bolts or bolts at the base of appropriate size and an arm which rotates round the axis of the pillar itself.

The **GBP-MBE wall-mounted** jib crane consists of a bracket support structure which is bolted on the support structure (fixed to the wall or anchored to a pillar) and an arm which rotates around an axis on the support bracket.

Both versions are equipped, in most cases, with a chain hoist, fitted with a trolley.

Pillar (GBA-CBE pillar-mounted version):

Made of pressed steel bent in a tubular structure with a polygonal shape it allows a high rigidity and stability for the crane; it is fixed to the base using a base plate and a system of bolts or log bolts. In the upper part a couple of plates support the arm of the crane and allow it to rotate (fig. 2).

Support bracket (GBP-MBE wall-mounted version):

It is formed of a couple of plates made of pressed steel; fixed to the wall or anchored to a pillar using staybolts or screws, it acts as a support to the arm and allows it to rotate (fig. 3).

The rotating arm:

The arm, rotating around its own axis on grazing ball bearings, is formed by a support girder for the sliding of the hoist-carrying trolley and comes in **three basic models for loads from 125 to 2000 kg and ranges up to 8 m.** (fig. 4):

▶ **The arm in the channel model "S":**

Made with the use of a special section bar made of formed steel inside which the hoist-carrying trolley slides. The arm is fitted with one or two staybolts which support the shape and link it to the rising rotating tube. This model features extreme lightness of movement due to the low inertia from its own reduced weight. This model of the crane is normally supplied with a push trolley.

▶ **The arm in the staybolted girder model:**

Made using a double-T formed steel beam girder the lower flange of which the hoist-carrying trolley slides on. The arm is fitted with one or two staybolts for the support of the beam which connects it to the rising rotating tube. The crane can be used with push trolleys, electric trolleys or mechanical ones.

▶ **The arm in the cantilever model:**

Made using a double-T formed steel beam girder the lower flange of which the hoist-carrying trolley slides on. The girder is a self-supporting cantilever, without support staybolts, and it is directly solid, using suitable reinforcement, to the rising rotating tube. It allows an optimal use of the available space at a height, due to the absence of staybolts. The crane can be used with push-trolleys, electric trolleys or mechanical ones.

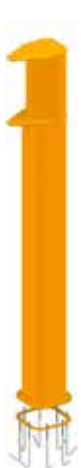

fig.2



fig.3



fig.4

The braking device of the arm:

It is made up of a clutch system with asbestos-free material, which allows the regulating of the rotating strain of the arm and ensures its positioning stability (fig. 5).

The electrical system:

It is intended for the electrical input of the hoist and/or trolley (if electric) which slides along the arm of the crane (fig. 6). It has a connector block, situated on the top of the pillar-mounted jib crane or on the arm support of the wall-mounted jib crane, for the connector between the line and the festooned cable.

The distribution of energy uses festoon-cable which does not spread flames, generally of the flat type, sliding on suitable coasters or sleds that slide the whole way along the arm, inserted in the arm or in a special channel.

Foundation frame with log bolts:

This is supplied on request in the pillar-mounted version, for the fixing of the pillar itself to the base (foundation plinth). (fig. 7).

Brackets and staybolts unit:

Used for fixing to a pillar in the wall-mounted version, it is available on request. It is fitted with a system of pressure screws to guarantee the best adherence of the staybolts to the pillar (fig. 8).

Finishing:

The protection of the steel structures from atmospheric and environmental agents (powders, gas, etc.) is guaranteed by the treatments which use yellow enamel paint, subject to preparation of the surfaces with metallic sanding of SA grade.

Lifting and translation unit:

The manually and electrically rotated jib cranes in the pillar-mounted or wall-mounted version can be equipped with a chain hoist with the relevant trolley either in electric or manual version.

For the measurements, weights and maximum admissible reactions on the wheels of the trolleys see the related table in paragraph "Technical data" 2.2



fig.5



fig.6



fig.7



fig.8

The conception and construction:

► The manually rotated **jib cranes** in the GBA-CBE pillar-mounted version and the GBP-MBE wall-mounted version are designed according to the conception of the modular components which put together in relation to commercial needs, as well as the standard models always available from the warehouse, allow the rapid economical realisation of numerous normalised and special executions.

- ▶ The base, pillar, bracket and arms components, thanks to their extreme compactness are assemblable together, so as to guarantee the maximum use of the hook run and, thanks to the minimal side clearance allow an optimal use of the area in which the jib crane operates.
- ▶ The construction uses the most advanced technology which is based on production processes of high industrialization and allows the realization, using economies of scale, of totally reliable and technically innovative machines. The high level of quality is guaranteed and controlled by the company quality system according to the UNI EN ISO 9001:2008 standard.

Electrical rotation system for arm-version CBE-MBE:

This consists of a motoreducer fixed vertically on the lower part of the support bracket, made up of an epicyclical reducer heat treated, permanently lubricated gear wheels and a conical brake self-braking motor.

The drive sprocket of the motoreducer fits with the toothed crown integral with the arm which it powers. Progressive starting-up and braking are ensured by a frequency inverter powered with alternate monophase current with voltage at 230 V.

The limit switch to limit the rotation of the arm, is of the type with worm screws with 4 contacts. It is fixed to the rotation stop with 3 screws, inserting the drive shaft of the limit switch in the toothed crown of the arm, which powers the rotation. The drive shaft is connected to a structure with 4 cams, which by rotating activate 4 switches which work on the low voltage auxiliary circuit.



Motoriducer



Limit switch

2.1.4 MAINTENANCE OF CBE ROTATION MOTOR REDUCER

ROUTINE MAINTENANCE	1ST OPERATION		SUBSEQUENT OPERATIONS			
	1 week	1 month	1 mese	3 months	1 year	4 years
1 Check the brake wear. Starting and braking are managed by inverters, and it is not normally necessary to make adjustments.		✓			✓	
2 Check the operation of the power supply and safety devices (rotation limit switches).		✓		✓		
3 Check the fastening and corrosion status of the fasteners.					✓	
4 Lubricate the motor reducer pinion and the crane rotation gear with grease.	✓			✓		
5 Replace the oil in the gear reducer.						✓

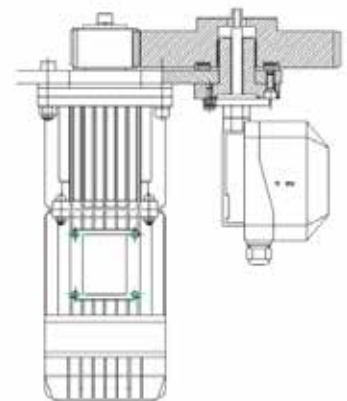

2.2 TECHNICAL INFORMATION AND SERVICE CONDITIONS

2.2.1 REGULATORY REFERENCE FRAMEWORK

In the planning and construction of the manually/electrically rotated jib cranes, pillar-mounted series GBA-CBE and wall-mounted series GBP-MBE the following standards and principal technical regulations have been taken into account:

- ▶ EN ISO 12100:2010 "General principles for design"
- ▶ EN ISO 13849-1:2008 "Safety-related parts of control systems" (where required).
- ▶ EN 6020432:2009 "Safety of machinery. Electrical equipment of machines. Requirements for hoisting machines"
- ▶ EN – 60529/97 "IP code"
- ▶ ISO 4301-1/88 "Cranes and lifting appliances --. Classification"
- ▶ FEM 1.001/98 "Rules for the design of hoisting appliances"
- ▶ FEM 9.683/95 "Selection of lifting and travel motors"
- ▶ FEM 9.755/93 "Measure for achieving safe working periods for motorised serial hoist units (S.W.P.)"
- ▶ FEM 9.941/95 "Graphical symbols for control devices"
- ▶ EN 16851/16 "Cranes – Light crane systems"

2.2.2 PROTECTION AND INSULATION OF ELECTRICAL PARTS

- ▶ Rotation motor: Protection IP55 (motor) IP23 (brake); insulation class "F"
- ▶ Electrical panel: Protection IP55 - Maximum voltage insulation 1500V
- ▶ Push-button panel: Protection IP65 - Maximum voltage insulation 600V
- ▶ Limit switch: Protection IP65 - Maximum voltage insulation 300V
- ▶ Cables: CEI 20/22 II - Maximum power insulation 450/750V

2.2.3 ELECTRICAL SUPPLY

- ▶ The CBE-MBE electrical rotation jib cranes are designed with a max. three-phase supply voltage of 480 V.

2.2.4 AMBIENT USE CONDITIONS

- ▶ Operating temperature: minimum - 10°C; maximum + 40°C
- ▶ Maximum relative humidity: 80%
- ▶ The machine must be installed in a well ventilated area, free from corrosive fumes (acid fumes, salt mist, etc.).



- ▶ **It is forbidden to use the machine in an explosive atmosphere or potentially explosive one or where the use of non-explosive components is required**
- ▶ **Sufficient work spaces must be provided in order to ensure the safety of the operator and personnel assigned to maintenance.**

2.2.5 NOISE - VIBRATION

- ▶ For both manual and electrical rotation jib cranes, noise level during functioning is below the prescribed limits adopted (70 dBA).
- ▶ The vibrations produced by the jib crane, during arm rotation, are practically zero and are not hazardous for the health of the personnel who operates it.
- ▶ Excessive noise or vibration may be caused by a fault which must be immediately reported and eliminated in order not to compromise the reliability of the job crane.

2.2.6 USE CRITERIA AND OPERATING CONDITIONS

One of the necessary and indispensable conditions to obtain the complete operating compliance of the jib crane, for the use it is intended for, as well as excellent and long-lasting operation of the same, consists of the correct selection of the machine model. This selection must be made based on the real service performance required as well as the ambient conditions where the crane will operate.

The parameters which must be carefully considered in the choice of jib crane are:

- ▶ **The capacity:** the maximum load weight to lift must be calculated and must not ever be less than the same.
- ▶ **The functional dimensions:** the height of the trolley beam which determines the hook run of the hoist, and its jump (jib) must be selected so as to guarantee the functional coverage of the area to be served in consideration of the surrounding encumbrances.
- ▶ **Type of travel:** manual or electric based on the characteristics of the mass to move.
- ▶ **Nature of the load:** delicate or not determines by its positioning the choice of the most suitable handling (lifting and travel) speeds. In some cases it is indispensable to use hoists with two speeds with a slow positioning speed.
- ▶ **Area of use:** the jib crane is characterised, by its conception, by intrinsic high elasticity which becomes even more evident when it is used for handling with loads close to the maximum lifting capacity and/or with prevalent localisation at the ends of the arm.
- ▶ **Ambient of use:** the jib cranes are intended to be used inside and/or in a covered area, sheltered from bad weather and wind. Measures must be taken for outdoor use for a suitable surface treatment (sandblasting - painting) as well as a self-braking system.
- ▶ **Frequency of use:** if use is very high (frequent and/or repeated manoeuvres) with loads close to the maximum load the consequent fatigue of the operator due to manual handling must be taken into consideration.



- ▶ **The correct evaluation of the parameters indicated above, may lead, if they are close to their limit values, to the need to use a crane with higher performance characteristics that, once declassified, may ensure greater rigidity and duration.**
- ▶ **The use of an electric trolley instead of a push trolley can also reduce operator fatigue.**

2.2.7 GBA-GBP SERIES - MANUAL ROTATION JIB CRANES: CHARACTERISTICS AND TECHNICAL DATA

S VERSION – MANUAL CHANNEL PROFILE VERSION

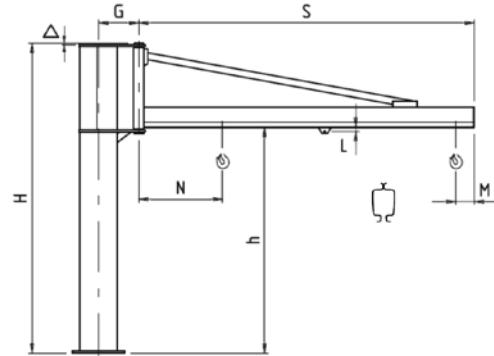
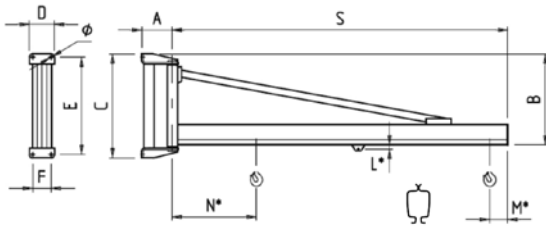
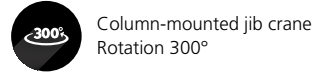
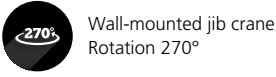

Heights L*, M* and N* for wall-mounted jib cranes: see corresponding heights relative to column-mounted jib cranes

LIFTING CAPACITY (kg)	ARM S		SIZE OF JIB CRANE			TROLLEY TYPE	GBP SERIES WALL-MOUNTED JIB CRANES - S VERSION								GBA SERIES COLUMN-MOUNTED CRANE - S VERSION											
	ARM (m)	ARM C/W COVER (mm)	BRACKET	COLUMN	COUNTERPLATE		CODE TYPE	OVERALL DIMENSIONS (mm)							WEIGHT CRANE kg	HEIGHT H m		CODE TYPE	OVERALL DIMENSIONS (mm)					WEIGHT		
								A	B	C	D	E	F	Ø		BASE	MAX.		UNDER BEAM h	G	L	M	N	Δ	JIB CRANE kg	COLUMN BY m kg
63	4	3999	A	R	R	1	S01A41	170	552	644	200	594	150	17	60.2	3	5	S30R41	2498	228	38	100	522	12	102.3	18.2
	5	4999	A	R	R	1	S01A51	170	552	644	200	594	150	17	68.1	3	5	S30R51	2498	228	38	100	582	12	110.2	18.2
	6	5997	C	T	T	2	S02C61	210	820	930	250	870	190	22	171.3	3.5	5.5	S30T61	2740	323	35	115	730	12	266.1	35
	7	6997	C	T	T	2	S02C71	210	820	930	250	870	190	22	189.3	3.5	5.5	S30T71	2740	323	35	115	790	12	284.1	35
125	2	1999	A	R	R	1	S01A23	170	552	644	200	594	150	17	44.4	3	5	S30R23	2498	228	38	100	452	12	86.5	18.2
	3	2999	A	R	R	1	S01A33	170	552	644	200	594	150	17	52.2	3	5	S30R33	2498	228	38	100	522	12	94.3	18.2
	4	3999	B	S	S	1	S01B43	170	552	644	200	594	150	17	60.1	3	5	S30S43	2498	274	38	100	522	12	116	22.8
	5	4999	B	S	S	1	S01B53	170	552	644	200	594	150	17	73.1	3	5	S30S53	2498	274	38	100	582	12	129	22.8
	6	5997	C	T	T	2	S02C63	210	820	930	250	870	190	22	171.3	3.5	5.5	S35T63	2740	323	35	115	730	17	266.1	35
	7	6997	C	T	T	2	S02C73	210	820	930	250	870	190	22	190	3.5	5.5	S35T73	2740	323	35	115	790	17	284.8	35
250	2	1999	A	R	R	1	S01A24	170	552	644	200	594	150	17	44.7	3	5	S30R24	2498	274	38	100	452	12	86.8	18.2
	3	2999	B	S	S	1	S01B34	170	552	644	200	594	150	17	52.6	3	5	S30S34	2498	274	38	100	522	12	108.5	22.8
	4	3997	C	T	T	1	S02C44	210	820	930	250	870	190	22	90.7	3.5	5.5	S35T44	2740	323	38	100	592	17	185.5	35
	5	4999	C	T	T	2	S02C54	210	820	930	250	870	190	22	152.2	3.5	5.5	S35T54	2740	323	35	115	670	17	247	35
	6	5997	D	U	U	2	S02D64	210	820	930	250	870	190	22	171.7	3.5	5.5	S35U64	2740	386	35	115	730	17	296.3	43.5
500	7	6997	D	U	U	2	S02D74	210	820	930	250	870	190	22	190	3.5	5.5	S35U74	2740	386	35	115	790	17	314.6	43.5
	2	1997	C	T	T	2	S02C25	210	820	930	250	870	190	22	94.5	3.5	5.5	S35T25	2740	323	35	115	540	17	189.3	35
	3	2997	C	T	T	2	S02C35	210	820	930	250	870	190	22	113.6	3.5	5.5	S35T35	2740	323	35	115	600	17	225.9	35
	4	3997	D	U	U	2	S02D45	210	820	930	250	870	190	22	132.7	3.5	5.5	S35U45	2740	386	35	115	600	17	257.3	43.5
	5	4997	D	U	U	2	S02D55	210	820	930	250	870	190	22	153.2	3.5	5.5	S35U55	2740	386	35	115	670	17	277.8	43.5
	6	5997	E	V	V	2	S03E65	255	1100	1240	300	1160	220	34	240.4	4	6	S40V65	2982	443	35	115	760	20	443.9	64
800	7	6997	E	V	V	2	S03E75	255	1100	1240	300	1160	220	34	269.8	4	6	S40V75	2982	443	35	115	830	20	473.3	64
	7	6997	F	Z	Z1	2D	S03F76	255	1100	1240	300	1160	220	34	296.1	4	6	S40Z76	2982	513	53	265	980	20	544.4	75.2
	2	1997	D	U	U	2D	S02D27	210	820	930	250	870	190	22	95.2	3.5	5.5	S35U27	2740	386	53	265	690	17	219.8	43.5
	3	2997	D	U	U	2D	S02D37	210	820	930	250	870	190	22	114.2	3.5	5.5	S35U37	2740	386	53	265	750	17	238.8	43.5
	4	3997	E	V	V	2D	S03E47	255	1100	1240	300	1160	220	34	193.5	4	6	S40V47	2982	443	53	265	780	20	397	64
	5	4997	E	V	V	2D	S03E57	255	1100	1240	300	1160	220	34	246.4	4	6	S40V57	2982	443	53	265	850	20	449.9	64
1000	6	5997	F	Z	Z1	2D	S03F67	255	1100	1240	300	1160	220	34	276	4	6	S40Z67	2982	513	53	265	910	20	524.3	75.2

T VERSION- MANUAL UNDERBRACED VERSION



Wall-mounted jib crane
Rotation 250°

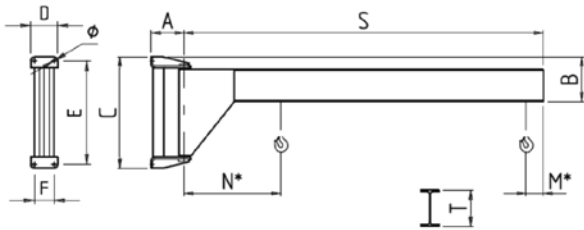

Column-mounted jib crane
Rotation 290°

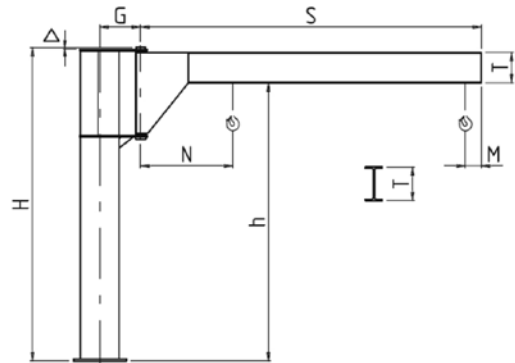

Heights M* and N* for wall-mounted jib cranes: see corresponding heights relative to column-mounted jib cranes

LIFTING CAPACITY (kg)	SIZE OF JIB CRANE				GBP SERIES WALL-MOUNTED JIB CRANES - T VERSION										GBA SERIES COLUMN-MOUNTED CRANE - T VERSION											
	ARM S m	BRACKET	COLUMN	COUNTERPLATE	CODE TYPE	OVERALL DIMENSIONS (mm)										HEIGHT H m		CODE TYPE	OVERALL DIMENSIONS (mm)						WEIGHT	
						A	B	C	D	E	F	Ø	WEIGHT CRANE kg	BASE	MAX.	UNDER BEAM h	G		M	N	T (IPE)	Δ	JIB CRANE kg	COLUMN BY m kg		
63	4	A	R	R	T01A41	170	248	644	200	594	150	15	95	3	5	T30R41	2800	228	190	655	160	12	148	18.2		
	5	A	R	R	T01A51	170	248	644	200	594	150	15	111	3	5	T30R51	2800	228	190	715	160	12	164	18.2		
125	2	A	R	R	T01A23	170	248	644	200	594	150	15	63	3	5	T30R23	2800	228	190	595	160	12	116	18.2		
	3	A	R	R	T01A33	170	248	644	200	594	150	15	79	3	5	T30R33	2800	228	190	655	160	12	132	18.2		
	4	B	S	S	T01B43	170	288	644	200	594	150	15	125	3	5	T30S43	2760	274	190	725	200	12	200	22.8		
	5	B	S	S	T01B53	170	288	644	200	594	150	15	147	3	5	T30S53	2760	274	190	785	200	12	222	22.8		
	2	B	S	S	T01B24	170	288	644	200	594	150	15	81	3	5	T30S24	2760	274	190	665	200	12	156	22.8		
250	3	B	S	S	T01B34	170	288	644	200	594	150	15	103	3	5	T30S34	2760	274	190	725	200	12	178	22.8		
	4	C	T	T	T02C44	210	346	930	250	870	190	22	195	3.5	5.5	T35T44	3212	323	190	800	240	17	320	35		
	5	C	T	T	T02C54	210	346	930	250	870	190	22	226	3.5	5.5	T35T54	3212	323	190	860	240	17	351	35		
	6	D	U	U	T02D64	210	406	930	250	870	190	22	340						190	1000	300					
	6	E	V	V	T03E64	255	500	1240	300	1160	220	34	410	4	6	T40V64	3640	443	190	1065	300	20	705	64		
	7	E	V	V	T03E74	255	500	1240	300	1160	220	34	555	4	6	T40V74	3580	443	190	1135	360	20	852	64		
	2	C	T	T	T02C25	210	346	930	250	870	190	22	134	3.5	5.5	T35T25	3212	323	190	740	240	17	260	35		
500	3	C	T	T	T02C35	210	346	930	250	870	190	22	165	3.5	5.5	T35T35	3212	323	190	800	240	17	290	35		
	4	D	U	U	T02D45	210	406	930	250	870	190	22	256	3.5	5.5	T35U45	3152	386	190	880	300	17	430	43.5		
	5	D	U	U	T02D55	210	406	930	250	870	190	22	298	3.5	5.5	T35U55	3152	386	190	940	300	17	472	43.5		
	6	E	V	V	T03E65	255	500	1240	300	1160	220	34	482	4	5	T40V65	3580	443	190	1140	360	20	779	64		
	6	F	Z	Z1										4	6	T40Z65	3580	513	190	1140	360	20	864	75.2		
	7	E	V	V	T03E75	255	540	1240	300	1160	220	34	596	4	4	T40V75	3540	443	190	1270	400	20	893	64		
	7	F	Z	Z1										4	6	T40Z75	3540	513	190	1270	400	20	978	75.2		
	1000	2	D	U	U	T02D27	210	406	930	250	870	190	22	172	3.5	5.5	T35U27	3152	386	190	820	300	17	346	43.5	
3		D	U	U	T02D37	210	406	930	250	870	190	22	214	3.5	5.5	T35U37	3152	386	190	880	300	17	388	43.5		
4		E	V	V	T03E47	255	499	1240	300	1160	220	34	381	4	6	T40V47	3580	443	190	945	360	20	678	64		
5		E	V	V	T03E57	255	499	1240	300	1160	220	34	438	4	6	T40V57	3580	443	190	1005	360	20	735	64		
6		F	Z	Z1	T03F67	255	540	1240	300	1160	220	34	530	4	4	T40Z67	3540	513	190	1190	400	20	912	75.2		
1600	7	F	Z	Z1	T03F77	255	590	1240	300	1160	220	34	688						190	1270	450					
	6	F	Z	Z2	T03F68	255	590	1240	300	1160	220	34	610						190	1270	450					
	2	E	V	V	T03E29	255	499	1240	300	1160	220	34	267	4	6	T40V29	3580	443	210	900	360	20	564	64		
	3	E	V	V	T03E39	255	499	1240	300	1160	220	34	324	4	6	T40V39	3580	443	210	960	360	20	621	64		
	4	F	Z	Z2	T03F49	255	540	1240	300	1160	220	34	400	4	6	T40Z49	3540	513	210	1070	400	20	780	75.2		
2000	5	F	Z	Z2	T03F59	255	590	1240	300	1160	220	34	535						210	1220	450					

H VERSION – MANUAL OVERBRACED VERSION



Wall-mounted jib crane
Rotation 270°

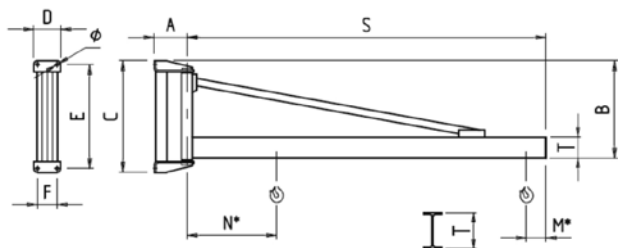

Column-mounted jib crane
Rotation 300°

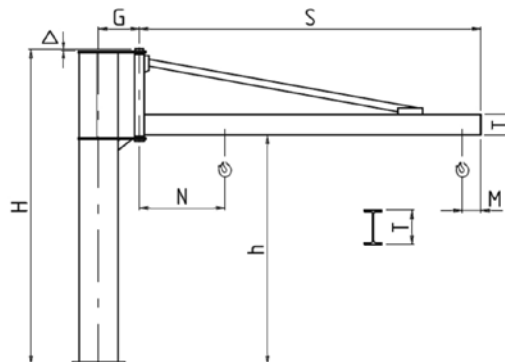

Heights M* and N* for wall-mounted jib cranes: see corresponding heights relative to column-mounted jib cranes

LIFTING CAPACITY (kg)	SIZE OF JIB CRANE			GBP SERIES WALL-MOUNTED JIB CRANES - H VERSION									GBA SERIES COLUMN-MOUNTED CRANE - H VERSION											
	ARM S m	BRACKET	COLUMN	COUNTERPLATE	CODE TYPE	OVERALL DIMENSIONS (mm)						WEIGHT CRANE kg	HEIGHT H m		CODE TYPE	OVERALL DIMENSIONS (mm)						WEIGHT		
						A	B	C	D	E	F		Ø	BASE		MAX.	UNDER BEAM h	G	M	N	T (IPE)	Δ	JIB CRANE kg	COLUMN BY m kg
125	6	C	T	T	H02C63	210	820	930	250	870	190	22	160	3.5	5.5	H35T63	2738	323	190	900	160	17	285	35
	7	C	T	T	H02C73	210	820	930	250	870	190	22	180	3.5	5.5	H35T73	2738	323	190	960	160	17	305	35
	8	D	U	U	H02D83	210	820	930	250	870	190	22	251	3.5	5.5	H35U83	2738	386	190	1070	200	17	425	43.5
250	4	C	T	T	H02C44	210	820	930	250	870	190	22	122	3.5	5.5	H35T44	2738	323	190	780	160	17	247	35
	5	C	T	T	H02C54	210	820	930	250	870	190	22	141	3.5	5.5	H35T54	2738	323	190	840	160	17	266	35
	6	D	U	U	H02D64	210	820	930	250	870	190	22	200	3.5	5.5	H35U64	2738	386	190	950	200	17	374	43.5
	7	D	U	U	H02D74	210	820	930	250	870	190	22	226	3.5	5.5	H35U74	2738	386	190	1010	200	17	400	43.5
	8	E	V	V	H03E84	255	1100	1240	300	1160	220	34	303	4	6	H40V84	2980	443	190	1140	200	20	620	64
500	4	D	U	U	H02D45	210	820	930	250	870	190	22	149	3.5	5.5	H35U45	2738	386	190	830	200	17	323	43.5
	5	D	U	U	H02D55	210	820	930	250	870	190	22	175	3.5	5.5	H35U55	2738	386	190	890	200	17	349	43.5
	6	E	V	V	H03E65	255	1100	1240	300	1160	220	34	262	4	6	H40V65	2980	443	190	1020	200	20	559	64
	7	E	V	V	H03E75	255	1100	1240	300	1160	220	34	293	4	6	H40V75	2980	443	190	1080	200	20	590	64
	8	F	Z	Z1	H03F85	255	1100	1240	300	1160	220	34	389	4	6	H40Z85	2980	513	190	1240	240	20	771	75.2
1000	4	E	V	V	H03E47	255	1100	1240	300	1160	220	34	200	4	6	H40V47	2980	443	190	900	200	20	497	64
	5	E	V	V	H03E57	255	1100	1240	300	1160	220	34	231	4	6	H40V57	2980	443	190	960	200	20	528	64
	6	F	Z	Z1	H03F67	255	1100	1240	300	1160	220	34	312	4	6	H40Z67	2980	513	190	1120	240	20	694	75.2
	7	F	Z	Z1	H03F77	255	1100	1240	300	1160	220	34	351	4	6	H40Z77	2980	513	190	1180	240	20	733	75.2
	8	F	Z	Z2	H03F87	255	1100	1240	300	1160	220	34	430	4	6	H40Z87	2980	513	190	1180	*152	20	812	75.2
1600	6	F	Z	Z2	H03F68	255	1100	1240	300	1160	220	34	312	4	6	H40Z68	2980	513	210	1140	240	20	694	75.2
2000	4	F	Z	Z2	H03F49	255	1100	1240	300	1160	220	34	233	4	6	H40Z49	2980	513	210	1020	240	20	615	75.2
	5	F	Z	Z2	H03F59	255	1100	1240	300	1160	220	34	272	4	6	H40Z59	2980	513	210	1080	240	20	654	75.2

* Profiled girder type HEA160

2.2.8 CBE-MBE SERIES - ELECTRICAL ROTATION JIB CRANES: CHARACTERISTICS AND TECHNICAL DATA

T VERSION- MANUAL UNDERBRACED VERSION



Wall-mounted jib crane
Rotation 290°

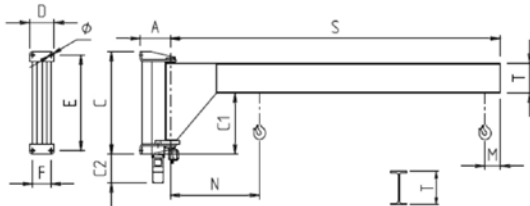

Column-mounted jib crane
Rotation 290°

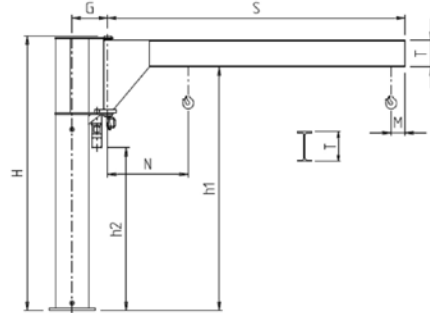

LIFTING CAPACITY (kg)	ARM S m	SIZE OF JIB CRANE	TYPE	MBE SERIES WALL-MOUNTED JIB CRANE - T VERSION - MOTORISED ARM IN CANTILEVER VERSION															
				OVERALL DIMENSIONS (mm)												ARM SPEED		MOTOR POWER kW	WEIGHT JIB CRANE kg
				A	B	C	C1	C2	D	E	F	Ø	M	N	T (IPE)	NO. OF REVOLUTIONS R.P.M.	PERIPHERAL m/min		
500	4	D	ET02D45	340	406	930	524	378	250	870	190	22	190	910	300	1	25	0.4	313
	5	D	ET02D55	340	406	930	524	378	250	870	190	22	190	970	300	0.8	25	0.4	355
	6	E	ET03E65	365	500	1240	740	348	300	1160	220	34	190	1080	360	0.6	23	0.4	574
	7	E	ET03E75	365	540	1240	700	348	300	1160	220	34	190	1270	400	0.6	26	0.4	680
1000	2	D	ET02D27	340	406	930	524	378	250	870	190	22	190	850	300	1.6	20	0.4	229
	3	D	ET02D37	340	406	930	524	378	250	870	190	22	190	910	300	1.2	23	0.4	271
	4	E	ET03E47	365	500	1240	740	348	300	1160	220	34	190	970	360	1	25	0.4	456
	5	E	ET03E57	365	500	1240	740	348	300	1160	220	34	190	1030	360	0.8	25	0.4	514
1600	6	F	ET03F67	365	500	1240	740	348	300	1160	220	34	190	1080	360	0.6	23	0.4	574
	6	F	ET03F68	365	590	1240	650	348	300	1160	220	34	210	1200	450	0.6	23	0.4	714
2000	2	E	ET03E29	365	500	1240	740	348	300	1160	220	34	210	930	360	1.6	20	0.4	341
	3	E	ET03E39	365	500	1240	740	348	300	1160	220	34	210	990	360	1.2	23	0.4	399
	4	F	ET03F49	365	540	1240	700	348	300	1160	220	34	210	1080	400	0.8	20	0.4	508
	5	F	ET03F59	365	590	1240	650	348	300	1160	220	34	210	1130	450	0.6	20	0.4	635

LIFTING CAPACITY (kg)	ARM S m	SIZE OF JIB CRANE	COUNTERPLATE	CBE SERIES COLUMN-MOUNTED JIB CRANE - T VERSION - MOTORISED ARM IN CANTILEVER VERSION														
				HEIGHT H mm		TYPE	OVERALL DIMENSIONS (mm)						ARM SPEED		MOTOR POWER kW	WEIGHT		
				BASE	MAX.		UNDER BEAM	G	M	N	T (IPE)	Δ	NO. OF REVOLUTIONS R.P.M.	PERIPHERAL m/min		JIB CRANE kg	COLUMN BY m kg	
500	4	U	U	3.5	5.5	ET35U45	3152	2250	436	190	910	300	17	1	25	0.4	476	43.5
	5	U	U	3.5	5.5	ET35U55	3152	2250	436	190	970	300	17	0.8	25	0.4	518	43.5
	6	V	V	4	5	ET40V65	3580	2492	463	190	1080	360	20	0.6	23	0.4	840	64
	6	Z	Z1	4	6	ET40Z65	3580	2492	513	190	1080	360	20	0.6	23	0.4	927	75.2
	7	V	V	4	4	ET40V75	3540	2452	463	190	1270	400	20	0.6	26	0.4	945	64
	7	Z	Z1	4	6	ET40Z75	3540	2452	513	190	1270	400	20	0.6	26	0.4	1032	75.2
1000	2	U	U	3.5	5.5	ET35U27	3152	2250	436	190	850	300	17	1.6	20	0.4	392	43.5
	3	U	U	3.5	5.5	ET35U37	3152	2250	436	190	910	300	17	1.2	23	0.4	434	43.5
	4	V	V	4	6	ET40V47	3580	2492	463	190	970	360	20	1	25	0.4	722	64
	5	V	V	4	6	ET40V57	3580	2492	463	190	1030	360	20	0.8	25	0.4	780	64
2000	6	Z	Z1	4	6	ET40Z67	3580	2492	513	190	1080	360	20	0.6	23	0.4	927	75.2
	2	V	V	4	6	ET40V29	3580	2492	463	210	930	360	20	1.6	20	0.4	607	64
	3	V	V	4	6	ET40V39	3580	2492	463	210	990	360	20	1.2	23	0.4	665	64
	4	Z	Z2	4	6	ET40Z49	3540	2492	513	210	1080	400	20	0.8	20	0.4	832	75.2

H VERSION – MANUAL OVERBRACED VERSION

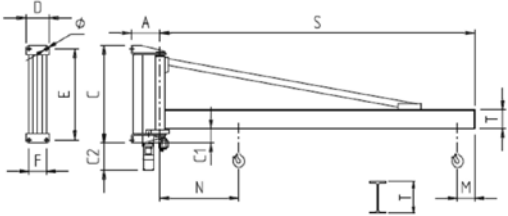

Wall-mounted jib crane
Rotation 290°

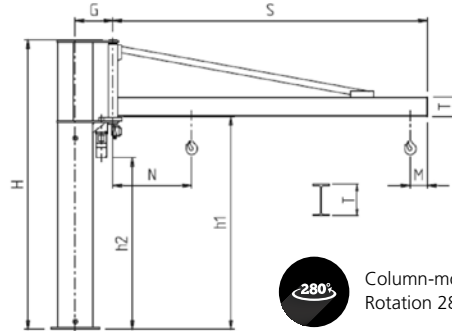

Column-mounted jib crane
Rotation 280°

LIFTING CAPACITY (kg)	ARM S m	SIZE OF JIB CRANE	TYPE	MBE SERIES WALL-MOUNTED JIB CRANE - H VERSION - MOTORISED ARM OVERBRACED VERSION															MOTOR POWER kW	WEIGHT JIB CRANE kg
				OVERALL DIMENSIONS (mm)												ARM SPEED				
				A	B	C	C1	C2	D	E	F	Ø	M	N	T (IPE)	NO. OF REVOLUTIONS R.P.M.	PERIPHERAL m/min			
250	6	D	EH02D64	340	778	930	152	378	250	870	190	22	190	1080	200	0.6	23	0.4	258	
	7	D	EH02D74	340	778	930	152	378	250	870	190	22	190	1200	*152	0.6	26	0.4	340	
	8	E	EH03E84	365	1058	1240	182	348	300	1160	220	34	190	1210	*152	0.6	30	0.4	497	
500	4	D	EH02D45	340	778	930	152	378	250	870	190	22	190	960	200	1	25	0.4	207	
	5	D	EH02D55	340	778	930	152	378	250	870	190	22	190	1020	200	0.8	25	0.4	233	
	6	E	EH03E65	365	1058	1240	182	348	300	1160	220	34	190	1090	200	0.6	23	0.4	334	
	7	E	EH03E75	365	1058	1240	182	348	300	1160	220	34	190	1210	*152	0.6	26	0.4	451	
1000	8	F	EH03F85	365	1058	1240	182	348	300	1160	220	34	190	1210	*152	0.6	30	0.4	497	
	4	E	EH03E47	365	1058	1240	182	348	300	1160	220	34	190	970	200	1	25	0.4	272	
	5	E	EH03E57	365	1058	1240	182	348	300	1160	220	34	190	1030	200	0.8	25	0.4	304	
	6	F	EH03F67	365	1058	1240	182	348	300	1160	220	34	190	1090	240	0.6	23	0.4	384	
1600	7	F	EH03F77	365	1058	1240	182	348	300	1160	220	34	190	1210	*152	0.6	26	0.4	451	
	8	F	EH03F87	365	1058	1240	182	348	300	1160	220	34	190	1210	*152	0.6	30	0.4	497	
	6	F	EH03F68	365	1058	1240	182	348	300	1160	220	34	210	1170	*152	0.6	23	0.4	420	
2000	4	F	EH03F49	365	1058	1240	182	348	300	1160	220	34	210	990	240	0.8	20	0.4	306	
	5	F	EH03F59	365	1058	1240	182	348	300	1160	220	34	210	1050	240	0.6	20	0.4	344	

LIFTING CAPACITY (kg)	ARM S m	SIZE OF JIB CRANE	COUNTERPLATE	CBE SERIES COLUMN-MOUNTED JIB CRANE - H VERSION - MOTORISED ARM OVERBRACED VERSION															MOTOR POWER kW	WEIGHT	
				HEIGHT H mm		TYPE	OVERALL DIMENSIONS (mm)						ARM SPEED		JIB CRANE kg	COLUMN BY m kg					
				BASE	MAX.		UNDER BEAM	G	M	N	T (IPE)	Δ	NO. OF REVOLUTIONS R.P.M.	PERIPHERAL m/min							
250	6	U	U	3.5	5.5	EH35U64	2780	2250	436	190	1080	200	17	0.6	23	0.4	420	43.5			
	7	U	U	3.5	5.5	EH35U74	2780	2250	436	190	1200	*152	17	0.6	26	0.4	507	43.5			
	8	V	V	4	6	EH40V84	3022	2492	463	190	1210	*152	20	0.6	30	0.4	765	64			
500	4	U	U	3.5	5.5	EH35U45	2780	2250	436	190	960	200	17	1	25	0.4	370	43.5			
	5	U	U	3.5	5.5	EH35U55	2780	2250	436	190	1020	200	17	0.8	25	0.4	395	43.5			
	6	V	V	4	6	EH40V65	3022	2492	463	190	1090	200	20	0.6	23	0.4	600	64			
	7	V	V	4	6	EH40V75	3022	2492	463	190	1210	*152	20	0.6	26	0.4	720	64			
1000	8	Z	Z1	4	6	EH40Z85	3022	2492	513	190	1210	*152	20	0.6	30	0.4	850	75.2			
	4	V	V	4	6	EH40V47	3022	2492	463	190	970	200	20	1	25	0.4	538	64			
	5	V	V	4	6	EH40V57	3022	2492	463	190	1030	200	20	0.8	25	0.4	570	64			
	6	Z	Z1	4	6	EH40Z67	3022	2492	513	190	1090	240	20	0.6	23	0.4	737	75.2			
1600	7	Z	Z1	4	6	EH40Z77	3022	2492	513	190	1210	*152	20	0.6	26	0.4	805	75.2			
	8	Z	Z2	4	6	EH40Z87	3022	2492	513	190	1210	*152	20	0.6	30	0.4	850	75.2			
	6	Z	Z2	4	6	EH40Z68	3022	2492	513	210	1170	*152	20	0.6	23	0.4	767	75.2			
2000	4	Z	Z2	4	6	EH40Z49	3022	2492	513	210	990	240	20	0.8	20	0.4	660	75.2			
	5	Z	Z2	4	6	EH40Z59	3022	2492	513	210	1050	240	20	0.6	20	0.4	697	75.2			

* Profiled girder type HEA160

2.2.9 GBA/GBP AND CBEIMBE: FIXING SYSTEMS FOR JIB CRANES

BRACKET AND STAYBOLTS UNIT FOR GBP/MBB/MBE SERIES WALL-MOUNTED CRANES

SIZE	A	B	C	D	E	F	
Reactions (kN)	Q2	2.95	5	9.2	16.85	26.10	28.2
	R	11.9	21.75	27.05	49	66.8	120

TYPE OF BRACKET	01	02	03		
Ø Staybolts/screws	M16	M20	M30		
Clamping torques (Nm)	Staybolts	128	250	857	
	Screws	205	400	1370	
Code	GBK010110	GBP020110	GBP030110		
Bracket Type: Short (mm)	U	50	60	80	
	V	420	490	532	
	Z	75	90	135	
Weight (kg)	21	36	75		
Pillar dimensions (mm)	x	min	200	250	300
		max	330	400	400
	y	max	850	810	750
Code	GBK010120	GBP020120	GBP030120		
Bracket Type: Medium (mm)	U	50	80	100	
	V	550	640	682	
	Z	75	120	145	
Weight (kg)	26	60	96		

TYPE OF BRACKET	01	02	03		
Ø Staybolts/screws	M16	M20	M30		
Pillar dimensions (mm)	x	min	200	250	400
		max	460	550	550
	y	max	850	770	710
Code	GBK010130	GBP020130	GBP030130		
Bracket Type: Long (mm)	U	60	80	120	
	V	740	840	882	
	Z	85	120	155	
Weight (kg)	40	74	132		
Pillar dimensions (mm)	x	min	460	550	550
		max	650	750	750
	y	max	830	770	670

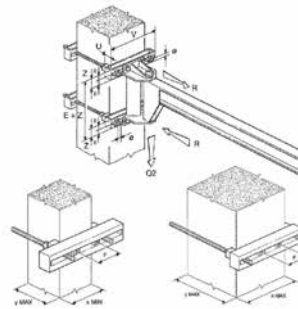

N.B.: The bracket and staybolts unit, used in the wall-mounted version for fixing the bracket to a pillar, is available on request.

BASE PLATES, FOUNDATION FRAMES AND PLINTHS FOR GBA/CBB/CBE SERIES COLUMN-MOUNTED CRANES

SIZE	R	S	T	U	V	Z	
Code foundation set	GBK1R0260	GBK1S0260	GBK1T0260	GBK1U0260	GBK1V0260	GBK1Z0260	
Base plate and foundation frame (mm)	∇C	205	258	296	372	435	515
	∇P	275	340	380	475	555	660
	S1	15	15	15	20	20	25
	S2	8	8	8	8	8	8
	x	247	305	345	432	506	599
	y	103	126	143	179	210	248
	Ø	268	330	373	468	548	648
	r	88	104	116	145	165	197
	Ø1	16	20	20	25	29	35
	Ø2	13	17	17	21	25	31
Lug bolts (mm)	ØT	M12	M16	M16	M20	M24	M30
	LT	400	450	450	550	600	700
	ST	40	45	45	55	60	75
Clamping torques (Nm)	45	105	105	200	350	680	
Frame/bolt weight (kg)	8	13	14	23	35	61	
Foundation plinth (mm)	∇L	1200	1300	1400	1700	2000	2400
	H	800	800	900	900	1100	1100
Reaction (kN)	Q1	3.3	5.7	10.15	18.4	28.7	29.35
Momentum (kNm)	MF	12	21	31	57	107	164

The dimensions of the plinths are purely indicative!

The plinth must be dimensioned by expert, qualified technicians considering the real consistency of the ground and the maximum pressure it can withstand.

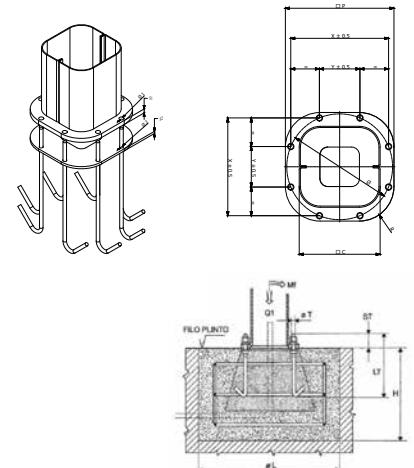

N.B.: The foundation frames with lug bolts, used in the column-mounted version for fixing the column itself to the foundation plinth is supplied on request.
* M= 1,11; ψ= 1,15

COUNTERPLATES FOR FIXING TO THE FLOOR WITH CHEMICAL BOLTS OF THE GBA/CBB/CBE COLUMN-MOUNTED CRANES

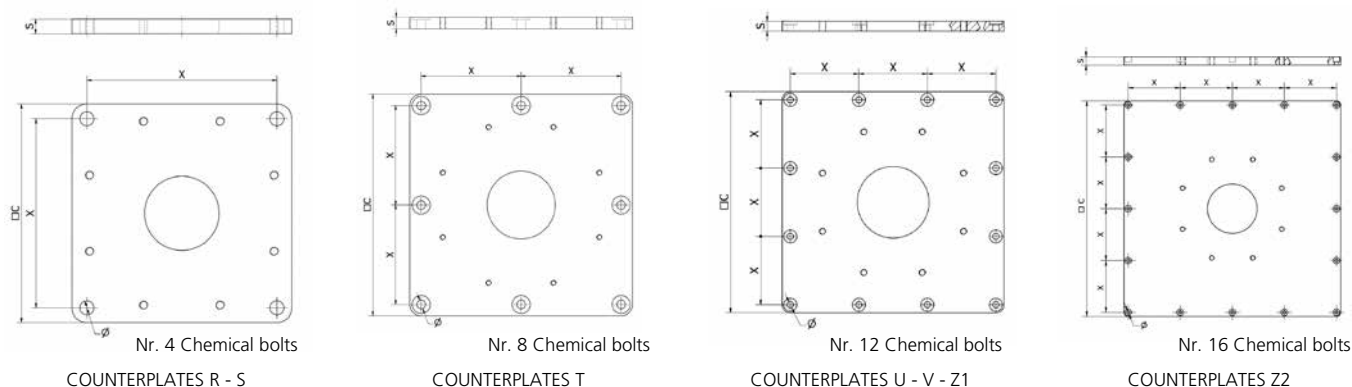

The fixing of the column using chemical bolts, needs a scrupulous check of suitability in relation to the type of support flooring. The suitability checks are the responsibility of the user and must be carried out by expert, qualified technicians who will evaluate the feasibility and formally undertake the relative responsibilities.

SIZE		R	S	T	U	V	Z1	Z2
Counter plate and chemical bolts code		GBA2R0KPS	GBA2S0KPS	GBA2T0KPS	GBA2U0KPS	GBA2V0KPS	GBA2Z1KPS	GBA2Z2KPS
Counterplate dimensions (mm)	∇ C	295	445	490	680	995	1130	1310
	S	20	20	25	30	40	40	50
	x	255	395	220	210	315	360	315
	Nr x Ø	4x19	4x19	8x19	12x19	12x19	12x19	16x19
Counterplate weight (kg)		15	30	45	100	285	375	640
Maximum tilting movement allowed (kNm)		Mf*	11,8	20,7	31,2	56,7	107,3	164
Type of concrete of the floor: Class Fck/Rck minimum (N/mm ²)		C20/25	C20/25	C20/25	C20/25	C20/25	C20/25	C20/25
Minimum floor thickness (mm)		170	170	170	170	170	170	170
Fixing characteristics	Diameter of hole in the floor (mm)	18	18	18	18	18	18	18
	Depth of the hole in floor's concrete (mm)	135	135	135	135	135	135	135
	Clamping torque of the bolts (Nm)	60	60	60	60	60	60	60
	Dowel height from top plate surface (mm)	45	45	40	35	25	25	15



The fixing of the pillar with chemical bolts requires a scrupulous check of suitability in relation to the type of support flooring. The suitability checks are the responsibility of the user and must be carried out by expert, qualified technicians who will evaluate the feasibility and formally undertake the relative responsibilities.

3. SAFETY AND ACCIDENT PREVENTION

The manually/electric rotated jib cranes, series GBA-CBE pillar-mounted, wall-mounted series GBP-MBE and relative accessories were designed and built based on the most modern technical knowledge and can be used safely.

The hazards for assigned personnel can be completely eliminated and/or significantly reduced only if the crane is used in accordance with the instructions contained in this documentation by authorised and specifically instructed personnel, in possession of sufficient preparation.



PERSONNEL IS RESPONSIBLE FOR THE FOLLOWING OPERATIONS: PERSONNEL IS RESPONSIBLE FOR THE FOLLOWING OPERATIONS:

Any installation and completion of the jib crane parts which may be missing (e.g. hoist, electric controls, anchoring accessories, etc.).

Commissioning of the crane and management of its operation.

Inspections and tests of the crane and its components, before start-up, during operation and even after it stops.





Maintenance of the crane and repair and/or replacement of its components.

The personnel must be absolutely informed on potential hazards they may encounter in performing their jobs, both in terms of operation and the correct use of safety devices available on the machine.

These personnel must also carefully comply with the safety rules contained in this chapter in order to prevent the occurrence of hazardous situations.

3.1 AUTHORISED OPERATOR QUALIFICATIONS

To better define the field of operation and the consequent undertaking of responsibility by each OPERATOR, given the specific training and achieved qualification, the following table has been prepared of the professional profiles with relative pictogram, necessary for all types of operation.

PICTOGRAM	MEANING	OPERATOR PROFILE
	Assigned to use	Operators assigned to use of the jib crane: Personnel assigned to perform only simple jobs, i.e. drive the crane through the use of controls and the loading and unloading operations of materials to handle.
	Mechanical maintenance personnel	Mechanical maintenance personnel: Qualified personnel able to intervene on the crane in normal conditions, make normal adjustments of the mechanisms, perform routine maintenance and mechanical repairs.
	Electrical maintenance personnel	Electrical maintenance personnel: Qualified personnel able to intervene on the crane in normal conditions and assigned to normal interventions of an electrical nature, adjustments, maintenance and repair. Able to work in the presence of voltage inside the panels.
	Mechanical technician	Mechanical technician: Qualified and authorised technician for performing complex and extraordinary operations of a mechanical nature.
	Electrical technician	Electrical technician: Qualified and authorised technician for performing complex and extraordinary operations of an electrical nature.

3.2 GENERAL SAFETY REGULATIONS

Before putting the jib crane into service, it is necessary to:











- ▶ Carefully read the technical documentation;
- ▶ Become informed on the operation and positioning of the emergency stop devices;
- ▶ Know what safety devices are installed on the crane and their location;

Some of the activities to perform on operating components (e.g. replacing the hoist chain) expose the operators to serious hazardous situations, therefore personnel must be authorised and specifically instructed on the operating procedures to follow, hazardous situations that may occur and the correct methods for avoiding them.

3.3 SAFETY SYMBOLS

Pictograms have been used in the manual to highlight any hazardous situations due to residual risks or actions which must be performed according to the safety procedures indicated their description.

PICTOGRAMS USED IN THE MANUAL TO HIGHLIGHT HAZARDOUS SITUATIONS

PICTOGRAM	MEANING
	Risk of being crushed during handling of suspended loads in the case of exposure of the operator or other personnel in the zones/areas involved in the trajectory of the load.
	Attention risk of being crushed by moving mechanical parts.
	Attention risk of being drawn in and dragged by moving parts (chain, wheels, etc.).
	Risk of electrocution - being shocked in the case of maintenance on the electrical equipment without disabling the electrical supply.
	It is prohibited to move through, stand, work or manoeuvre under the suspended load.
	It is forbidden to touch the crane arm and the trolley/hoist when moving or expose yourself to their trajectories.
	It is prohibited to work on the electrical equipment before having disconnected the hoist.
	It is prohibited to restart the hoist if the removed guards have not been put back.
	Protective gloves must be used.
	Comply with all of the instructions contained in this instruction manual.
	Is mandatory to perform a preventive check of chains, ropes, hooks, slings and accessories used for lifting and handling.

3.4 WARNINGS ON RESIDUAL RISKS

After having carefully considered the hazards present in all of the jib crane operating phases, measures have been adopted that are necessary to eliminate, as much as possible, the risks for operators and/or to limit or reduce the risks resulting from hazards that cannot be completely eliminated at the source. However, despite all of the adopted precautions, the following **residual risks** are on the machine that can be eliminated or reduced through the relative prevention activities:

RISKS DURING USE		
HAZARD / RISK	HAZARD / RISK	HAZARD / RISK



Risk of being crushed during handling of suspended loads in the case of exposure of the operator or other personnel in the zones/areas involved in the trajectory of the load.

It is prohibited to lift loads while people are going through the relative manoeuvre area.
It is prohibited to move through, stand, work or manoeuvre under the suspended load.

The operator assigned to use must follow the indications to obtain the best safety by complying with the instructions contained in this manual. The rope and hook must be checked periodically.



Risk of being drawn in and/or crushed following contact with the arm in rotation and/or with the moving parts of the trolley/hoist.

Attention! Exposure to moving parts may create hazardous situations.
It is forbidden to touch the crane arm and the trolley/hoist when moving or expose yourself to their trajectories.

It is mandatory to use gloves during the slinging and pushing phase of the load.

RISKS DURING MAINTENANCE		
HAZARD / RISK	HAZARD / RISK	HAZARD / RISK



Risk of electrocution - being shocked in the case of maintenance on the electrical equipment without disabling the electrical supply.

It is prohibited to work on the electrical equipment before having disconnected the jib crane from the electrical line.

Assign the electrical maintenance operations to qualified personnel. Perform the tests on the electrical equipment contained in the manual.



Risk of being crushed in the event of contact with the rotation arm during the brake adjustment phase.

Attention! Exposure to moving parts may create hazardous situations.

Assign the brake adjustment operations to qualified maintenance personnel. Use protective gloves and, if necessary, safety harnesses.

3.5 SAFETY DEVICES AND INSTRUCTIONS

3.5.1 CONTROL DEVICES

Jib cranes, in both GBA-CBE pillar-mounted version and GBP-MBE wall-mounted version can be controlled in the following ways:

1. If equipped with an **electric hoist and push trolley** movements are activated:
 - ▶ **from a pushbutton panel** with “lift and lower” buttons to control the **lifting** movement.
 - ▶ **by pushing the load** to control the **traverse** trolley.
2. If equipped with an **electric hoist and electric traverse trolley** movements are activated:
 - ▶ **from a pushbutton panel** with “lift and lower” buttons to control the **lifting movement**.
 - ▶ **from a pushbutton panel** with “right and left” buttons to control the **traverse movement**.
3. If equipped with a **manual hoist and trolley** movements are activated:
 - ▶ **by mechanical activation** of the hoist chain for the **lifting** movement.
 - ▶ **by pushing the load** to control the **traverse** trolley.
4. The **rotation movement of the jib crane arm**, both clockwise and anticlockwise, is activated manually with P&T pushing the load (fig. 9) **or electrically from the pushbutton panel**.

3.5.2 SAFETY AND EMERGENCY DEVICES FOR GBA- GBP

The **manually rotated jib cranes** in the GBA pillar-mounted version and the GBP wall-mounted version, are fitted with the following safety and emergency devices (fig. 10): SEE ALSO ARM-IN-RAIL MOUNTING

- ▶ Rotating brake, by friction, which allows the regulation of the arm’s rotating force and ensures the stability of positioning. (1).
- ▶ Trolley-end limit switches, mechanical catches which limit the maximum run of the trolley along the arm’s girder. (2).
- ▶ Mechanical limit switch actuators (in the case of the crane with electric trolley), limit switch striker plates of the trolley’s electrical microswitches. (3).
- ▶ Limit switches for the arm’s ends supplied on request, mechanical catches which limit the maximum rotation of the arm.
- ▶ Anti-collision device, available on request, to avoid the telescoping of two or more arms which, operating in the same area, can interfere with each other; or to avoid the collision of the arm with surrounding structures.



fig.9

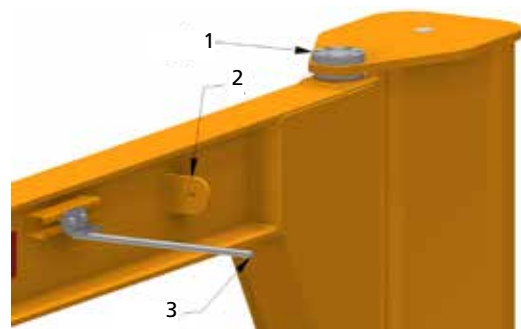

fig.10

3.5.3 SAFETY AND EMERGENCY DEVICES FOR CBE E MBE

The electric powered jib cranes pillar type CBE series and wall type MBE series are supplied complete with the following safety and emergency devices:

1. Electrical rotation limit switch, which is as emergency limit switch on the rotation movement, has to limit the rotation of the jib.
2. Trolley-end limit switches, mechanical catches which limit the maximum run of the trolley along the arm's girder.
3. Limit switches for the arm's ends supplied on request, mechanical catches which limit the maximum rotation of the arm.
4. Anticollision device, available on request, avoids any crash between 2 or even more jibs operating in a same area, or prevents from any contact or interference with close existing structures.



CBE

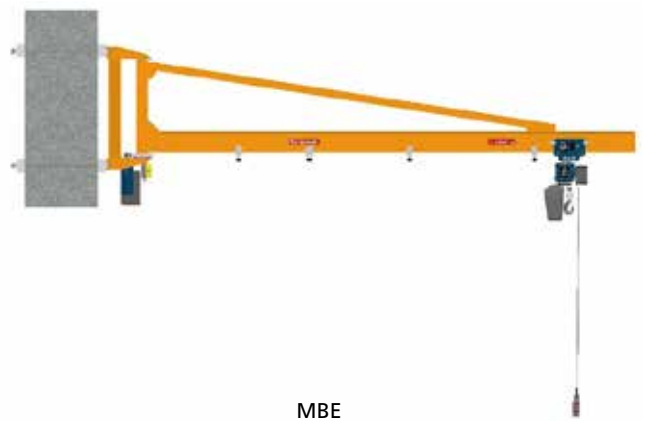

MBE

3.5.4 WARNING AND NOTICE DEVICES - SIGNAGE SUMMARY

The manually/electric rotated jib cranes, pillar-mounted series GBA-CBE and wall-mounted series GBP-MBE, are fitted with the following devices.

Plates present on the machine:

- ▶ manufacturer's **donati** logo. (fig. 11a)
- ▶ jib crane data plate with CE mark. (fig. 11b)
- ▶ plate indicating the maximum capacity of the jib crane. (fig. 11c)
- ▶ directional labels (only for T- and H-models). (fig. 11d)
- ▶ warning plates for residual risks. (fig. 11e-11f)
- ▶ hoist plates, and trolley plate (if any)

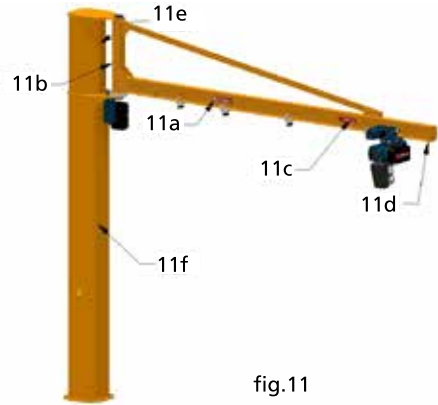

fig.11



fig.11a



fig.11b



fig.11c



fig.11d



fig.11e



fig.11f

Legibility and preservation of the plates

The plates must always be kept legible in terms of all the data contained in them by periodically cleaning them. If a plate deteriorates and/or is no longer legible, including just one of the informational items shown, it is advisable to request another one from the manufacturer, quoting the data contained in this manual or on the original plate and then replace it.



The plates must never be removed and it is absolutely prohibited to affix other plates on the crane without prior authorisation from DONATI SOLLEVAMENTI S.r.l.

4. HANDLING - INSTALLATION COMMISSIONING

4.1 GENERAL NOTES FOR DELIVERY



- ▶ The manually/electric rotated jib cranes of the GBA-CBE pillar-mounted version and the GBP-MBE wall-mounted version, are delivered not assembled, in their main parts which are the pillar or bracket, the arm, the electric system and, when part of the supply, the lifting unit.
- ▶ The user must therefore proceed to the phases of installation of the jib crane following the instructions contained in this chapter and assigning if possible the assembly to specialised installers.



- ▶ Due to their delicacy and importance, the operations described in this chapter if not performed correctly may result in serious risks for the safety and health of exposed persons during the installation and use phases of the jib crane.
- ▶ Therefore, they must be performed by professionally qualified personnel with a specialisation in assembling industrial plants, with an electromechanical background, equipped with work equipment and personal protection equipment in compliance with current laws on occupational safety and after having carefully read this publication.



After receiving the supply check and make sure that:



1. The shipping data (address of the recipient, no. of parcels, etc.) match what is contained in the accompanying documentation (transport document and/or any packing list).
2. The technical/legal documentation supplied with the jib crane includes:
 - ▶ The "User instructions" manual of the crane to install.
 - ▶ CE Declaration of Conformity.
 - ▶ Test logbook, when included.
 - ▶ Instructions for using the hoist / trolley to install on the crane, if they are part of the supply.
 - ▶ chain and hook certificates (if included in the supply).
3. The packaging, if part of the supply, is in good condition, intact, and free from damage.



In the event of damage or missing parts report the problem to the shipper, putting a written reservation on the accompanying document and notifying the manufacturer within eight days from receiving the goods.

4.2 PACKAGING, TRANSPORT AND HANDLING



Before handling the jib crane and its accessories you should know that:

4.2.1 STANDARD PACKAGING

- ▶ The metalwork parts of the jib crane (column and arm) are generally supplied with packaging, hooking points are present on the columns to make it easier to move them during installation operations (fig. 12).
- ▶ To make handling and assembly operations easier for the lifting unit, if it is part of the supply, it can be delivered in a cardboard box (with or without pallet) or, where included, in a crate or wooden cage or even simply on a pallet.
- ▶ When the lifting unit is delivered on a pallet, it is generally covered with a protection against dust composed of a polyethylene film.
- ▶ Any other accessories which are part of the supply (e.g.: electrical system components) can be delivered inside or in cardboard boxes that, based on the weight to move, can be with or without a pallet.
- ▶ The standard packaging is not waterproof against rain and is designed for destinations via land and not via sea, for covered and non-damp environments. Therefore, special packaging or protections are excluded from the supply unless they are contained in the contract.
- ▶ If necessary, the packaging can include signs and pictograms that provide important information regarding handling and transport (weight, lifting points, storage information, etc.) - (fig. 13).
- ▶ Appropriately preserved parcels can be stored for a period of around two years in covered environments where the temperature ranges from -20°C to +60°C with relative humidity of 80%. Specific packaging needs to be prepared for different environmental conditions.

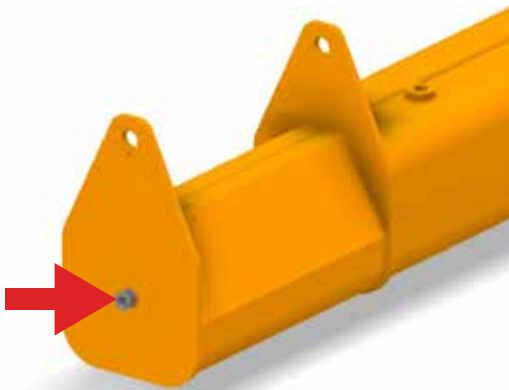
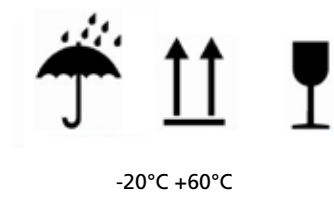

fig.12

Hook points consist in welded nuts, matching UNI2947/ DIN 580, eyebolts having the following dimensions:

- M 16** for:
 - ▶ Pillar type R – S – T – U
 - ▶ Bracket

- M 20** for:
 - ▶ Pillar type V – Z



-20°C +60°C

fig.13

4.2.2 TRANSPORT

- ▶ The transport must be performed by qualified shippers able to guarantee correct handling of the transported material.
- ▶ Avoid placing parcels on the parts of the jib crane or other packaged parts that could cause damage during the transport.
- ▶ During transport phases it is advisable that the pallets or crates/cages not be turned over or upside down, to avoid dangerous changes in their barycentre and to thus constantly guarantee the best stability for them.



DONATI SOLLEVAMENTI S.r.l. shall not be held liable for transports made by the customer or shippers chosen by the customer.

4.2.3 HANDLING



To move the jib crane, proceed as follows:



- ▶ Prepare a limited and adequate area, with flat flooring or ground, for unloading and placing the bulk metalwork parts and components contained in the packaging on the ground.
- ▶ Based on the type of part/component or the packaging, prepare the equipment necessary for unloading and handling of the crane parts and its accessories taking into account their weight, overall dimensions and gripping and/or suspension elements.
- ▶ Unloading and handling may be performed by crane (e.g. mobile cranes, bridge cranes, etc.) or forklifts, with adequate capacity and characteristics and the use of special equipment is not required.
- ▶ The parcels of any accessories with a weight less than 30 kg (unlike those with a weight greater than 30 kg) do not show any indication of their weight and can be handled by hand.
- ▶ Sling the crane parts with suitable equipment in order not to damage the painted surfaces:
 - ▶ for the columns, use rope or chain tie rods with terminal hooks positioned at the indicated points or harness with "noose" textile fibre bands.
 - ▶ for columns and arms use stay bolts with rope or chain with end hooks positioned in the indicated points or slings with a textile fibre band and "loop" in a barycentric position or in the indicated lifting points.
- ▶ Very carefully grip and move the crane parts and its accessories to the area set up for unloading and avoid swinging, tilting and any dangerous unbalancing.
- ▶ When they have been moved check that the parts and parcels are intact and free from damage.



- ▶ Moving of the jib crane parts and relative accessories must be done very carefully and with adequate lifting and transport means, in order not to generate hazards due to the risk of a loss of stability.
- ▶ All of the parts or components must be placed or fixed stably in all phases of the movement, transport and storage phases and must not be flipped over or placed vertically or on their sides (fig. 14).

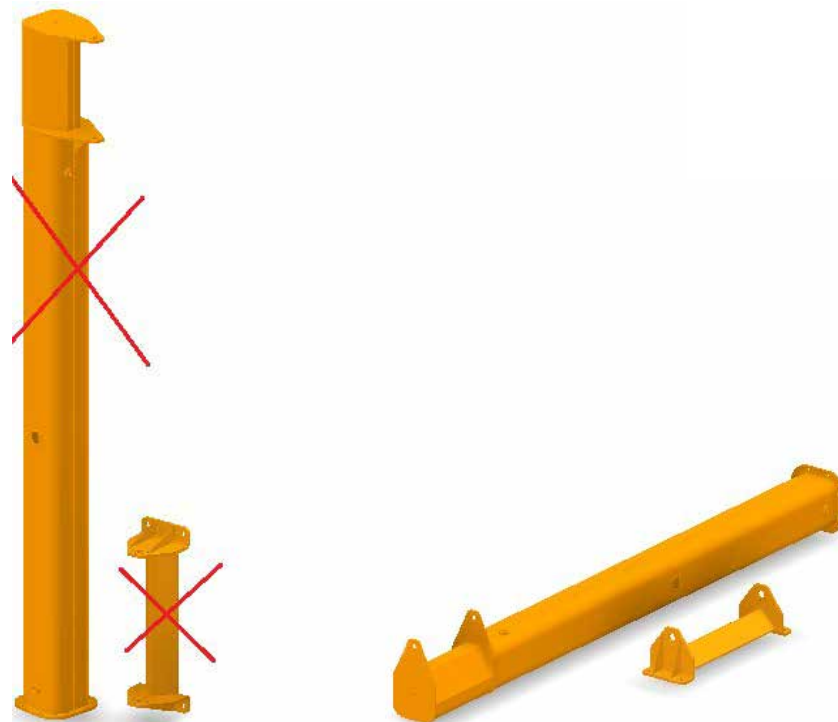

fig.14

4.2.4 REMOVAL OF THE PACKAGING AND/OR CHECKING OF THE CRANE PARTS

- ▶ In the case of packaged parcels, open the packaging and extract the various parts using suitable equipment chosen in relation to their weight and grip points.
- ▶ Check the conditions of all of the material of the supply and make sure no parts and/or accessories are missing. Notify the manufacturer immediately if anything is damaged or missing.
- ▶ If the material is going to be stored follow the instructions in paragraph 4.5.1 "Decommissioning".



- ▶ Check the conditions of all the crane parts and in particular check that:
 - ▶ the columns and arms have not been crushed, deformed, bent or have any broken parts.
 - ▶ there is no damage to the components of the electrical system (if included)
- ▶ Dispose of the packaging as required by regional waste disposal laws based on the nature of the waste (wood, plastic, cardboard), after sorting it.

4.3 JIB CRANE INSTALLATION

4.3.1 INSTALLER DUTIES AND RESPONSIBILITIES



- ▶ Installation of the jib crane, due to the importance of the operations, may cause, if not correctly performed, serious risks for the safety of exposed persons both in the assembly phase and subsequent crane use phase. Therefore, if not performed by the manufacturer it must be entrusted to installers specialised in the assembly of industrial plants.
- ▶ Lifting and overhead placement of crane parts must be performed by installers equipped with:
 - ▶ adequate and suitable personal protection equipment (e.g. helmet, gloves, safety belt, etc.).
 - ▶ equipment (e.g.: forklift, scaffolding, etc.) adequate for the purpose
- ▶ And after a careful evaluation of the following parameters:
 - ▶ environmental characteristics of the work site (e.g.: walk on surfaces, etc.)
 - ▶ height of the work surface compared to the loading surface
 - ▶ dimensions and weight of the parts to install
 - ▶ spaces available for handling the parts to install



Before carrying out the assembly of the parts and installation of the jib crane, the installer must make sure that the crane specifications are in compliance with what was requested and the intended use and in particular:



1. The crane capacity is \geq compared to the loads to lift.
2. The specifications of the anchoring structures (plinth, floor, wall, pillar, etc.) have been **“Declared suitable”** by the customer or expert technicians appointed by the customer.
3. The specifications of the lifting unit (trolley/hoist), if not part of the supply, are compatible with those of the jib crane (see point 2.2.7) in relation to: (fig. 15)
 - a. **Hoist capacity:** must be \leq compared to the jib crane capacity.
 - b. **Weight of the trolley/hoist:** must be \leq compared to the maximum weights.
 - c. **Lift/traverse speed** must be \leq compared to the maximum ones allowed.
 - d. **Overall dimensions of the trolley/hoist:** must be \leq compared to the maximum ones allowed.
 - e. **Reactions on the trolley wheels:** must be \leq compared to the maximum ones allowed.



fig.15



Following the jib crane installation activities, the installer must:



1. Conduct the "Commissioning", activities as described in paragraph 4.4;
2. Draft the "Acceptance test" report and approve the jib crane "Suitable for use".

4.3.2 PREPARATION OF THE INSTALLATION SITE



Before assembling the parts and setting up the jib crane, the installer must ensure that the crane's characteristics comply with the requirements and intended use, in particular:



1. Verify the presence of the suitable/adequate declaration of the support/anchoring structures;
2. Verify the absence of clear defects of the support/anchoring structures (fig.16);
3. Verify the suitability of the manoeuvre (rotation) spaces for the jib crane, especially if operating in areas where other cranes or operating machines are present (fig.17);
4. Verify the suitability and correct operation of the mains: (fig.18):
 - a) correspondence of the line voltage with the voltage required for the motors;
 - b) presence and suitability of the electrical line switch/circuit breaker;
 - c) adequacy of the cable cross section of the electrical line;
 - d) presence and suitability of the earthing system;
5. In case of a jib crane with an arm with a section bar of laminated girder (H- or T-type), check the width of the flange of the girder which must correspond to that intended for the trolley wheels (fig.19);
6. Prepare the masses for the **dynamic tests** equal to: **rated capacity x 1.1**;
7. Prepare the masses for the **static tests** equal to: **rated capacity x 1.25**;
8. Prepare the equipment for slinging and lifting of the masses for the load tests;
9. Verify the presence of signs warning of the risks due to handling with the crane.

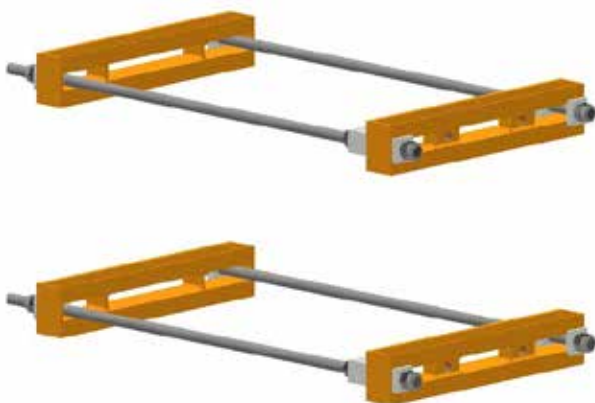

fig.16

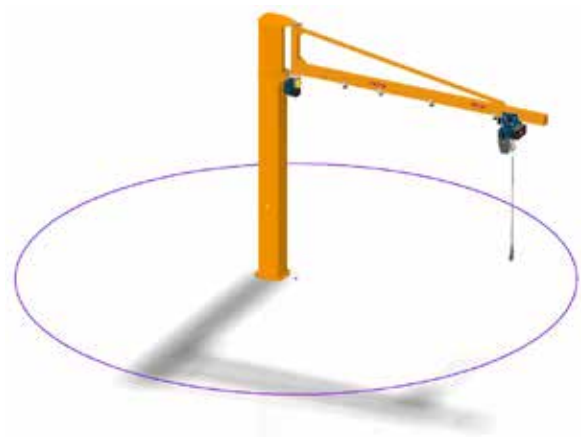

fig.17



fig.18

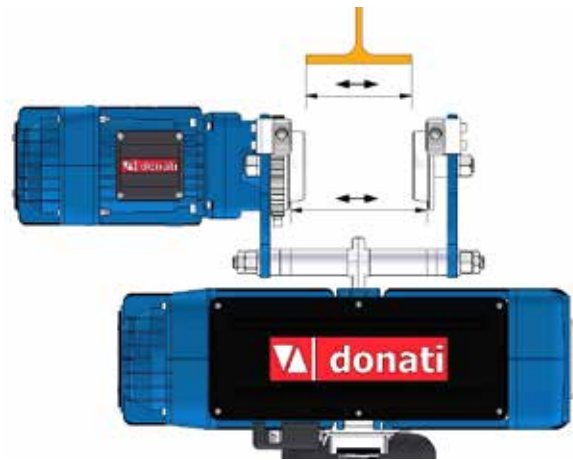

fig.19

4.3.3 GBA – CBE: ASSEMBLY OF THE PILLAR (FOUNDATION PLATE, COUNTERPLATE, PILLAR)



The column can be anchored to the ground in the following manners:

- ▶ using the foundation frame with stay bolts embedded in a plinth formed in reinforced concrete.
- ▶ using bolts and expansion bolts or with chemical anchoring.



- ▶ The anchoring of the column using bolt, expansion bolts or with chemical anchoring, needs a scrupulous check of suitability in relation to the type of support flooring.
- ▶ The technical data so that the customer can dimension the foundation plinth, are indicated in the table shown in paragraph 2.2.9 "GBA/GBP and CBE/MBE: Fixing systems for jib cranes". The plinth must be dimensioned in relation to the real consistency of the ground and the specific maximum pressure that it can allow.
- ▶ The suitability checks of the foundation are the responsibility of the user and must be carried out by expert, qualified technicians who will evaluate the feasibility and assume the relative responsibilities.



Positioning of the foundation frame in the plinth:



1. Screw the lower nuts 2 on the stay bolts 1 letting the threaded portion protrude until obtaining the corresponding protrusion ST (see paragraph 2.2.9) (fig. 20). Carry out this operation on all 8 (eight) stay bolts.
2. Insert all of the bolts 1 in the holes of the foundation frame 4 so that the plate of the frame sits on the nuts and tighten with the high nuts 5 inserting the washers 3.
3. Embed the frame prepared this way in the plinth casting making sure that the upper plate remains flush with the floor (fig. 21). Protect the threading of the bolts to prevent damage.
4. If required, prepare insertion of a pipe in the plinth adequate for passage of the electrical cable to supply the jib crane (fig. 22).
5. Level the foundation frame, possibly using a level and fill and scrape the plinth (fig. 23).
6. Wait for the time necessary for the plinth to solidify before mounting the column.

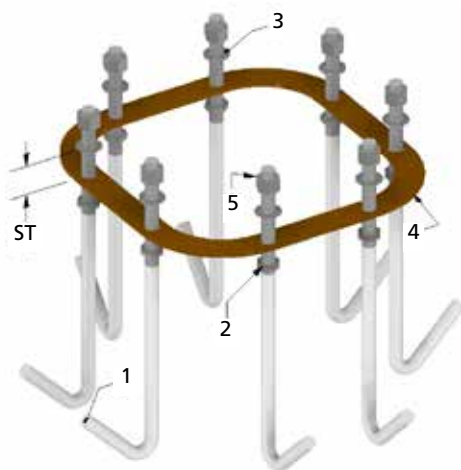

fig.20

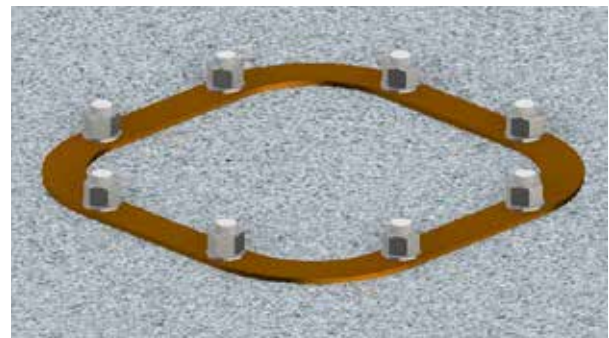

fig.21



fig.22

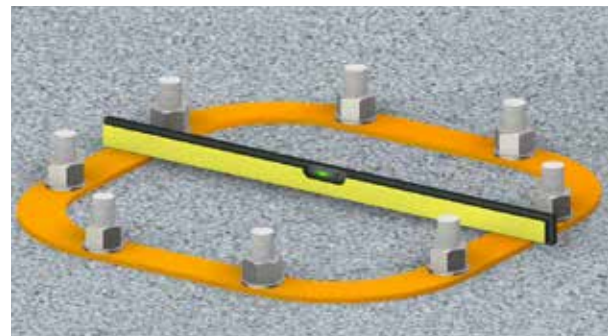

fig.23



Positioning of the counterplate with chemical bolts:



To ensure the hold of the fixing operate as follows:

- Check that the inclination of the surface where the counterplate is to be fitted is within the tolerances shown in fig. 24; otherwise level the surface. Do not insert shims between the floor and counterplate.
- Drill the cement surface with a punching machine or core borer using the counterplate as a template.
- Accurately clean with sprayed water and a pipe cleaner.
- Follow the assembly instructions for the bolts used.
- Once it has been embedded, the work time when the bars need to be positioned and the time in which it is necessary not to work in order to let it harden completely, are specified on the instruction booklet present in every package of bolts.
- After the time required for curing has elapsed, position the counterplate with the hole slits (if present) facing upwards and fix it following the instructions in the bolt booklet.



The fixing of the column using chemical bolts, needs a scrupulous check of suitability in relation to the type of support flooring. The suitability checks are the responsibility of the user and must be carried out by expert, qualified technicians who will evaluate the feasibility and formally assume the relative responsibilities.

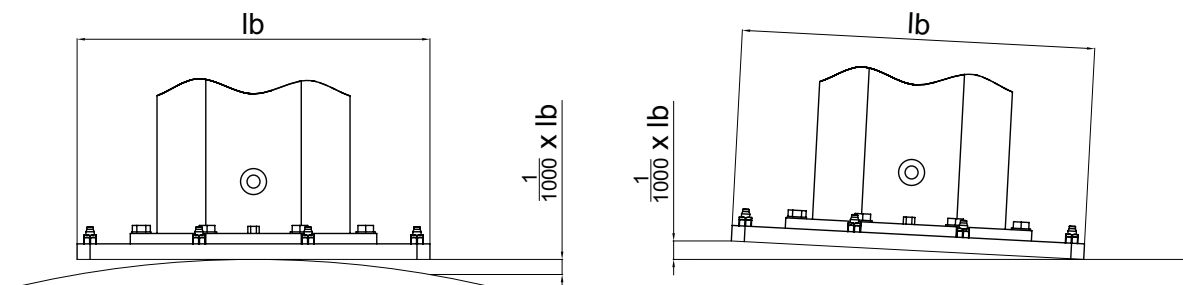

fig.24



Pillar assembling:



On a **foundation frame** (plinth):

- When the plinth has solidified, remove the protection of the bolt threading and check that the high nuts unscrew without forcing, then remove them and the washers.
- Where required insert the power supply cable 1 in the column positioned on the ground and let it protrude from the hole located at the top of the column based on the following lay-out positions:
 - In the case of cable 1 that protrudes from the pipe set up in the plinth, directly insert the cable in the column until reaching hole 2 located at the top of the column (fig. 25)
 - In the case of cable 1 coming from the outside, insert it into the column using the specific grommet 3 located at the base of the column, until reaching hole 2 at the top (fig. 26)
- Erect the column without arm, lifting it in the upper part with suitable equipment after having slung it as indicated, mount it on the foundation frame positioning base plate 4 correctly and approaching the nuts 6 after placing the relativ flat washers 5 (fig. 27).

On a **counterplate with chemical bolts**:

1. Once the counterplate has been fixed, push the power cable 1 into the pillar on the ground and through the hole at the top of the pillar, according to the following layout: if the cable 1 comes from outside, push it into the pillar using a suitable fairlead 3 placed at the bottom of the pillar, until it reaches hole 2 at the top (fig. 26).
2. Set up the pillar without the arm, lifting it by the upper part with appropriate equipment having put it in the sling as shown, assemble it on the counterplate positioning the base plate 4 correctly and secure it using the special Kit supplied with the counterplate (fig. 28) (proceed with step 4).
4. Check the verticality of the rotation axis as follows:
 - a. Remove the protective plastic plugs from the housing of the pivots.
 - b. Insert the pivots provisionally in their respective housing (see 4.3.5 Assembly of the arm).
 - c. Check the verticality of the rotation axis, by using a level L which must be resting directly on the rotation pivots (fig. 29).
 - d. The perfect plumbing can be obtained, if necessary, inserting suitable shims (not part of the supply), under the front brackets.
5. Stably screw the 6 nuts using a torque wrench, applying the clamping couples (see table on page 17) based on the diameter of the log bolts/bolts, checking the nuts afterwards for unscrewing with the relative safety nuts 9 (fig. 30).
6. For correct tightening in torque of the nuts/bolts at the bottom of the column all of the nuts/bolts need to be brought into contact with the plate applying a light torque in order to prevent free movement. Once in this situation, using a torque wrench, tighten the nuts in torque (see the nuts/bolts clamping table on page 18 for the correct value) following the shown cross pattern (fig. 31) and being careful that the column does not lose its vertical alignment. It is recommended to tighten in two steps: the first at 70% of the clamping couple and the second at 100%.
7. Once the bolts are tightened, control and, if needed, fix the paint around the bolts in order to avoid possible corrosion.

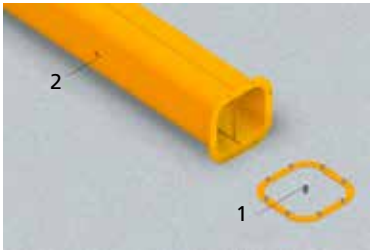

fig.25

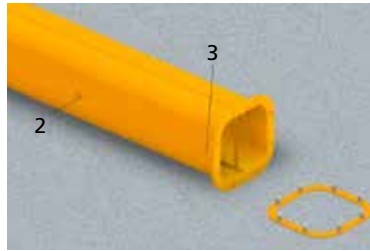

fig.26

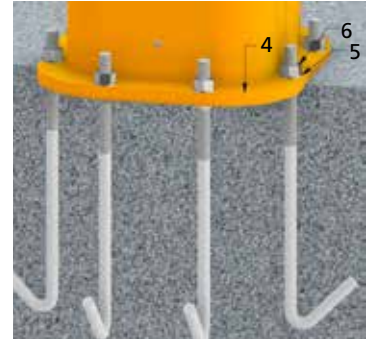

fig.27

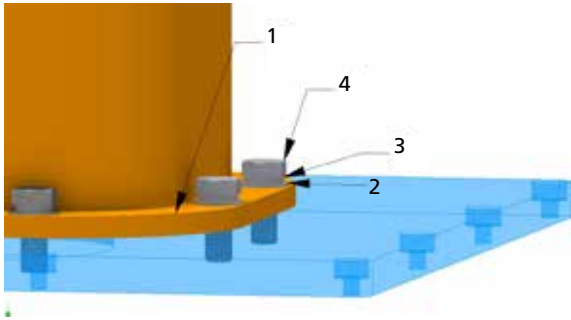

fig.28

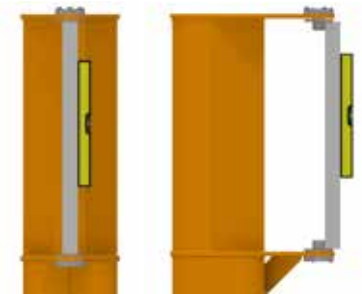

fig.29



fig.30

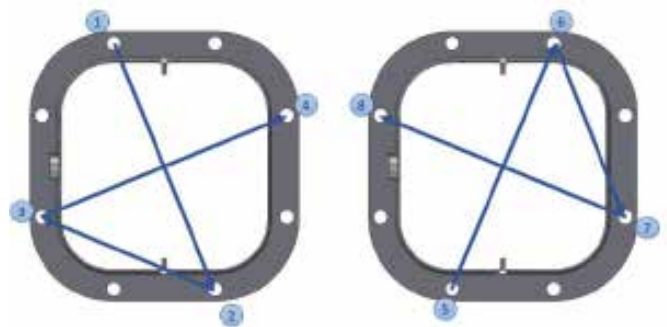

fig.31



After the first lifting operations it is advisable to check nut tightening again, to take up any play due to settlement of the plinth.



Donati Sollevamenti SRL shall not be held liable for any fixings other than those indicated in fig. 27 and fig. 28.

4.3.4 GBP – MBE: ASSEMBLY OF THE BRACKET (STIR-UPS, BRACKET)



The fixing of the bracket to the support structure can take place as follows:

- ▶ using brackets with the related staybolts.
- ▶ using bolts and screw anchors or dowelling.



▶ The fixing of the bracket using bolts and screw anchors or dowelling, requires a scrupulous check of suitability in relation to the type of support.

▶ Technical data, so that the user can scale the fixings to the right size are shown in the table at paragraph 2.2.7 “GBA/GBP and CBE/MBE: Fixing systems for jib cranes”.

▶ The suitability checks of the support structure are the responsibility of the user and must be carried out by expert technicians who evaluate the feasibility and take on the related responsibilities.



Assembly of the brackets to the pillar or load-bearing wall:



1. Screw up the nuts 1 on the four staybolts T and insert the contrast panels 2 (fig. 32).
2. Assemble the two brackets, the front one 3 and the back one 4, for the fixing of the upper part of the bracket, in such a position to obtain the required height under the arm of the crane, inserting the safety washers 5 and the cramping nuts 6 on the staybolts T (fig. 33).
3. Pretighten the nuts 6 to ensure good adherence to the pillar brackets (fig. 34).

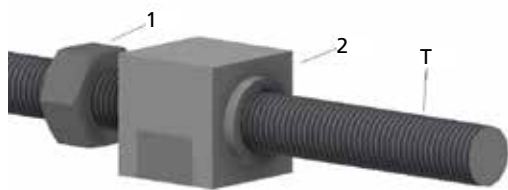

fig.32



fig.33



fig.34



Assembly of the brackets:



1. Assemble on bracket 1 the other front bracket (fig. 35).
2. Lift the bracket to a height with suitable equipment, by putting it in the sling as shown and fix it to the front bracket previously positioned on the pillar (fig. 36).
3. Assemble on the front bracket fixed on the bracket, the other back bracket (fig. 37).
(Refer to the preceding point "Assembly of the brackets" at positions 1 and 2)

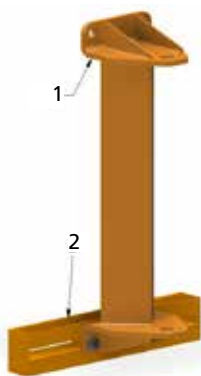

fig.35

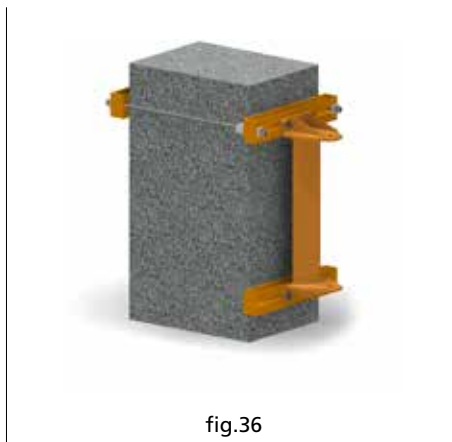

fig.36



fig.37

4. Check the verticality of the rotation axis as follows:
 - a. Remove the protective plastic plugs from the housing of the pivots
 - b. Insert the pivots 7 provisionally in their respective housing (see 4.3.5 - "GBA/CBE – GBP/MBE: Assembly of the arm")
 - c. Check the verticality of the rotation axis, by using a level L and a bar B which must be resting directly on the rotation pivots 3 (fig. 38a - 38b).
 - d. The perfect plumbing can be obtained, if necessary, inserting suitable shims 4 (not part of the supply), under the front brackets 5 (fig. 39).
5. Check the correct positioning of the four contrast boards 6, checking that the centring crowns 7 are well settled in their respective housing of the front brackets (fig. 40).
6. Using a mallet, stick the level of the contrast boards 6 to the surface of the pillar (fig. 41).
7. Tighten thoroughly the blocking nuts 8 of the contrast boards 6.
8. Screw up the back blocking nuts 9 of the staybolts and block them using a dynamometric spanner, applying the clamping couples (see table on page 17), based on the diameter of the staybolts, checking the nuts afterwards for unscrewing with the related safety nuts 10 (fig. 42).
9. Check again the perpendicularity of the rotation axis as described in point 4

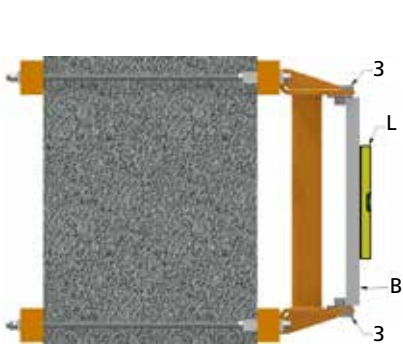

fig.38a

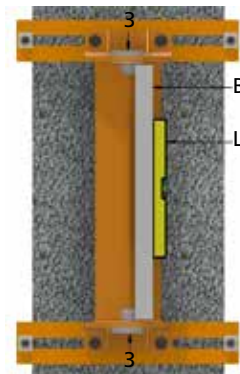

fig.38b

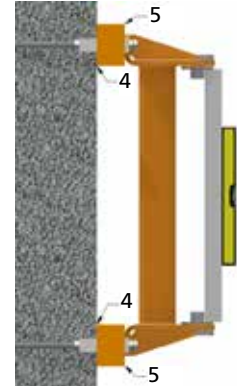

fig.39

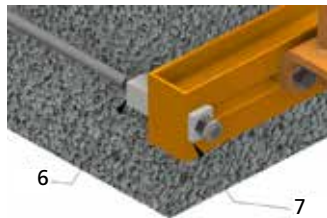

fig.40



fig.41

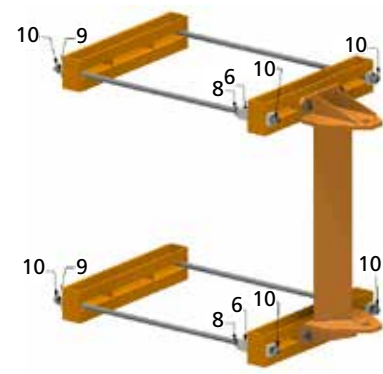

fig.42



It is recommended that, after the first lifting operations the clamping of the nuts is checked, to take up any slack due to the settling of the brackets.

4.3.5 GBAICBE – GBPIMBE: ASSEMBLY OF THE ARM



For the assembly of the arm proceed as follows:



1. Sling the arm, using strips made of textile fibre arranged in a "loop", corresponding to the handling points shown on the labelling and lift it with suitable means (overhead travelling crane, travelling crane, etc.). Keep the girder horizontal to the ground and constantly check the stability of the slinging which must not move from the handling point. Avoid oscillations and swinging and, if necessary, to maintain the equilibrium use a rope tied to the ends of the arm.
2. Line the arm up with the plates (of the bracket or pillar) and position the clutch plate 2 and the pressure plate 3 in the upper part of the tube, making sure at the same time that the clutch plate 2 and the pressure plate 3 fit into the lower part (fig. 43).
3. Insert the tube between the plates 4 until the rotation axis of the tube coincides with that of the plates and insert the rotation pivots 5, after lubricating them with grease (fig. 44).
4. Block, with the clamping couples shown in the table, the pivots 5 with their related screws 6 in the three holes at 120 on the pivots' flange 5 (fig. 45).
5. Insert in the remaining holes of the upper side pivots' flange 5, the springs 7 and the screws 6 checking carefully that the shank of the screws fits into the housing on the pressure plates 8 (fig. 46).
6. Regulate the slidability of the rotation of the arm, by acting on the braking system using register/adjuster screws 6, until the traverse sensitivity required is obtained.
7. Carry out the check of the planarity of the arm 9 with the help of a level L. Do this check by rotating the arm by 90° to the left and to the right (fig. 47).

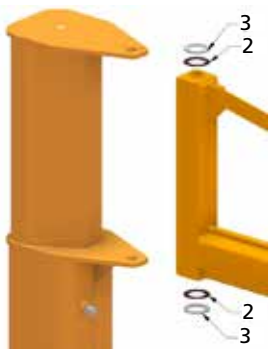

fig.43



fig.44

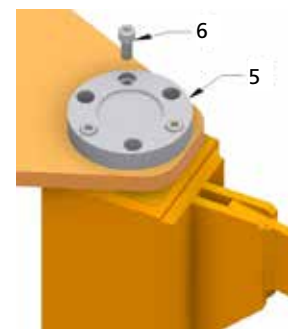

fig.45

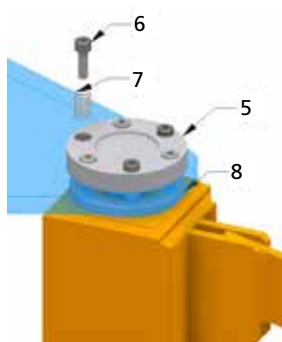

fig.46

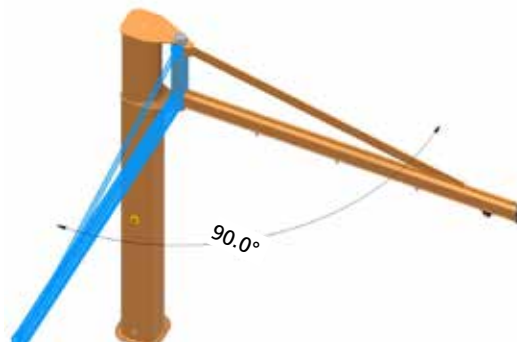
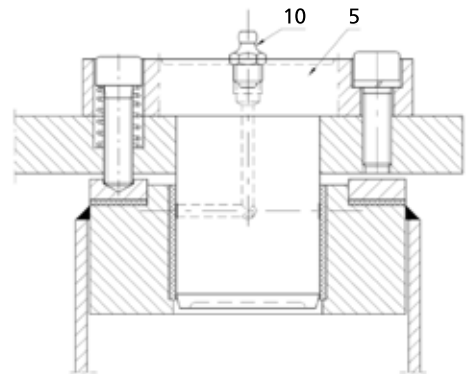

fig.47

In the case of crane series CBE-MBE size V-Z integrate at the point 5

5.1 Insert into the central hole of the upper side pivots' flange (5), the greaser (10) and introduce the grease with the proper equipment.

Note: Check and grease every three months.



For the assembly of the motoreducer proceed as follows:



- ▶ Insert the motoreducer, with the sprocket already mounted, in the centring hole of the lower plate.
- ▶ Align the teeth of the sprocket to the spaces of the crown.
- ▶ Insert the 4 TCEI M10 screws in the holes of the flange by positioning the 2 longer screws above the plate, tightening them with their respective self-blocking nuts and then positioning the 2 shorter ones under the plate and screwing them directly to it.
- ▶ The clamping couple of the screws must be of 32 Nm.
- ▶ Once the electrical connections have been made, check the rotation direction of the arm in both directions and the operation of the limit switch.

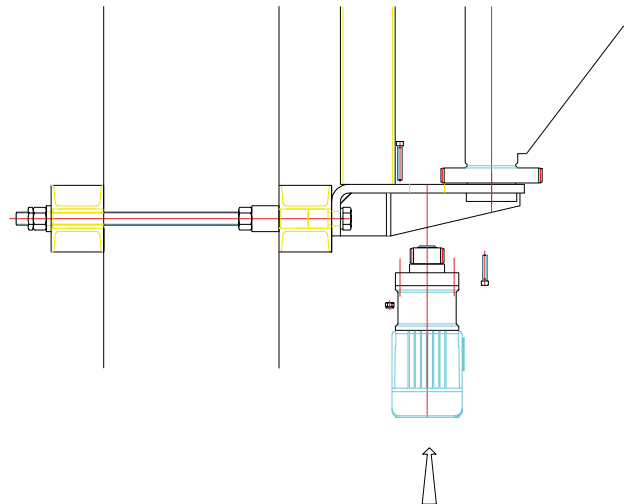

- ▶ **Keeping the arm clean is one of the indispensable conditions for its good sliding and to avoid a premature deterioration of the rotation elements.**
- ▶ **Moderate lubrication with grease of the bearings is necessary, but dirtying with lubricant the surfaces of clutch plates and the area where these function should be avoided.**

4.3.6 S PROFILES CHANNEL ARM

	S1	S2
Capacity (kg)	Arm Length (m)	
63	4-5	6-7
125	2-3-4-5	6-7
250	2-3-4	5-6-7
500	/	2-3-4-5-6-7
800	/	7
1000	/	2-3-4-5-6

4.3.7 MOUNTING OF THE TROLLEY BLOCK INSIDE THE S PROFILE CHANNEL ARM

To correctly assemble the trolley block, first of all a suitable work environment is needed to drill the channel profile. The correct drilling scheme is shown in the figure below (dis.1) and the dimensions can be found in the following table

- ▶ Arm S1: D2=32mm e $\Phi=9.5\text{mm}$
- ▶ Arm S2: D2=50mm e $\Phi=9.5\text{mm}$

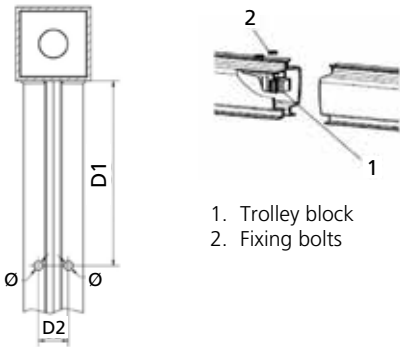

D1	2	3	4	5	6	7
Capacity (kg)	Arm length (m)					
63			430	490	590	650
125	360	430	430	490	590	650
250	360	430	500	530	590	650
500	400	460	460	530	620	690
800						690
1000	400	460	490	560	620	



- ▶ Before inserting the trolley block S1, tighten the provided blots (fig. 48) to realize the seat for the head of the screws (fig. 49 e fig. 50) This passage will simplify the next fixing operation because when the bolts are removed, the screws don't move. (fig. 51).
- ▶ In trolley bloc S2 (fig. 52) the bolts are welded with the main body.

Internal trolley bumper S1



Internal trolley bumper S2



4.3.8 ASSEMBLY OF THE ELECTRIC SYSTEM WITH THE CONNECTOR BLOCK



For the assembly of the electric system proceed as follows:



1. Extract the cable, the sleds or slides and the other electrical components from any packing.
2. Insert the power cable 1 in the cable-carrying sleds 2, in the case of the channel - bar (fig. 53), or in the slides 3, in the case of the "girder" arm (fig. 54), so as to form a series of festoons of equal width. Tighten the cable with the related screws or seatings.
3. Insert the sleds, or slides, in the relative sliding housings (channel-girder or double-T"girder") -(fig. 55a-55b).

In the case of the GBA pillar-mounted crane:

4. Connect the electric cable 1 and the cable of line (inserted previously in the pillar – see 4.3.3 – "GBA – CBE: Assembly of the pillar (foundation plate, counterplate, pillar)" - Pos. 2) - to the terminals 4 contained in the connector block - (fig. 56a-56b).

In the case of the GBP wall-mounted crane:

4. Connect the electric cable 1 to the terminals 4 contained in the connector block, to be applied to the pillar or load-bearing wall and to which the cable of line coming from the power supply will be connected - (fig. 57a-57b).



fig.53

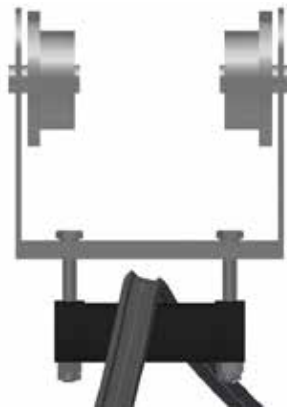

fig.54



fig.55a

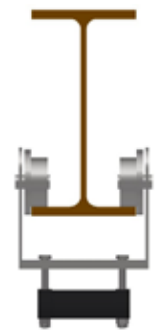

fig.55b

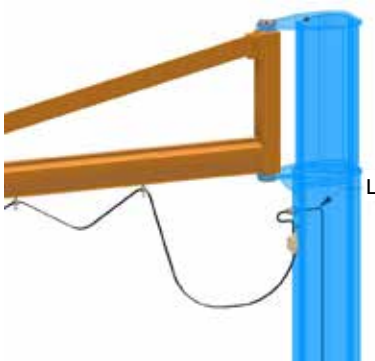

fig.56a

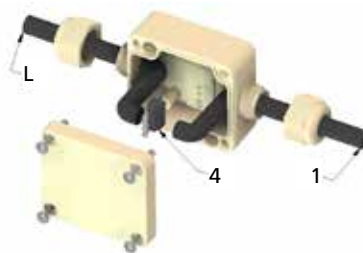

fig.56b



fig.57a

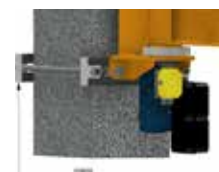

fig.57b



The user or installer assigned by the user must:

- ▶ install, in the immediate vicinity of the crane, a line switch, protected against short circuits, showing its function with the appropriate label.
- ▶ Have earthing connected, to the structure of the crane, corresponding to the handling points for this Purpose (fig. 57a-57b).

In the case of pillar crane series CBE

4. Connect the power cable (3) in the rotation control device (4) to the L1-L2-L3-N-EARTH terminals.
5. Connect the rotation limit switch cable (5) to the terminals corresponding to the wiring diagram.
6. Connect the flat cable of the hoist/trolley power supply (6) to the terminals corresponding to the wiring diagram.
7. Mount and connect the main on/off switch as indicated in point 4.3.8.1.

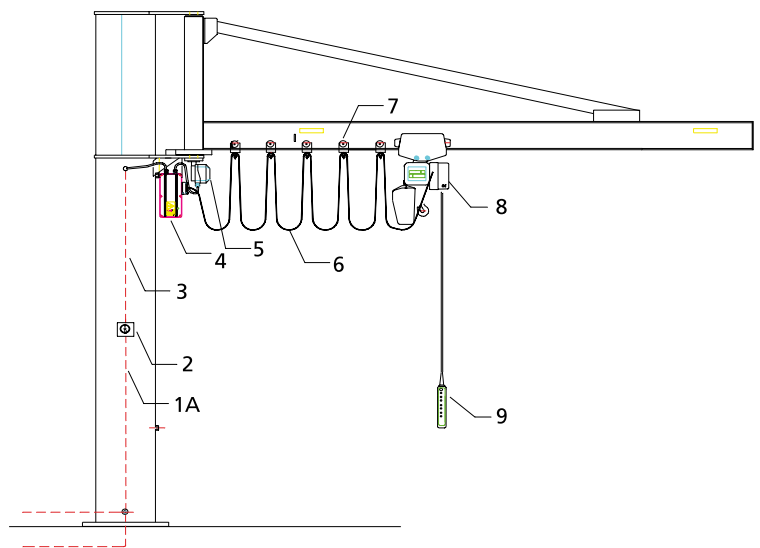

In the case of MBE series wall mounted cranes

4. Connect the power cable (1B) in the rotation control device (4) to the L1-L2-L3-N-EARTH terminals.
5. Connect the rotation limit switch cable (5) to the terminals corresponding to the wiring diagram.
6. Connect the flat cable of the hoist/trolley power supply (6) to the terminals corresponding to the wiring diagram.
7. Connect the power cable 1B to the terminals contained in the junction box.

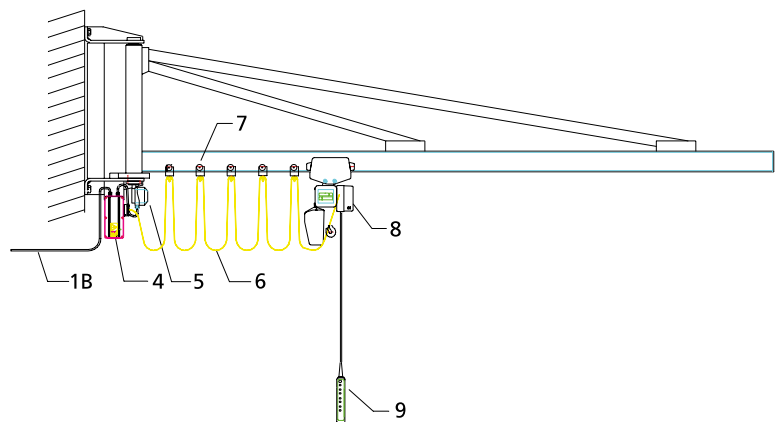

COMMISSIONING OF THE ROTATION LIMIT SWITCH

Operate as follows:

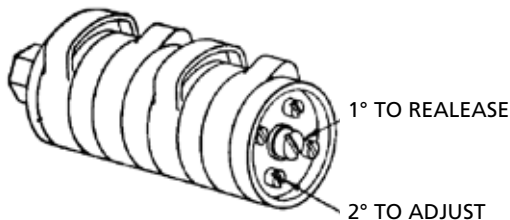

Function of the contacts:

SQ5A = RIGHT rotation service limit switch

SQ6A = LEFT rotation service limit switch

SQ5B = RIGHT rotation emergency limit switch

SQ6B = LEFT rotation emergency limit switch

Adjusting the contacts:

- 1) Adjust the cam related to the SQ5B emergency contact immediately after the operation on the Adjust the cam related to the SQ5A contact to limit the rotation to the RIGHT, as required. SQ5A contact.
- 2) Adjust the cam related to the SQ6A contact to limit the rotation to the LEFT, as required. Adjust the cam related to the SQ6B emergency contact immediately after the operation on the SQ6A contact.

Note:

the operation on the emergency limit switch contacts blocks the functioning of the whole machine. To activate an emergency operation, once the cause is identified, it is necessary to operate on the limit switch, releasing momentarily the cam of the contact in question.

Get out of the anomalous position with the opposite control to that of the operation.

Restore the original position of the contacts.

4.3.8.1 Assembly of the electric system with isolating switch for GBA-CBE pillar-mounted cranes



For the assembly of the electric system proceed as follows:



1. Extract the cable trolleys or cable sliders and the other components from any packing.
2. Insert the power cable 1 in the cable sliders 2, in the case of the channel girder (fig. 56), or in the cable trolleys 3 in the case of the girder arm (fig. 54), so as to form a series of festoons of equal width. Clamp the cables with the relative screws or seatings.
3. Insert the sleds, or slides, in the relative sliding housings (channel-girder or double-T"girder") - (fig. 55a-55b).
4. Assemble the isolator switch as in fig. 56b, assembling the components 1-2-3-4-5.
5. Position the isolating switch in the hole in the pillar, connecting the relative electric cables, finishing the assembly with the application of the yellow frame and of the red knob as in fig. 58.

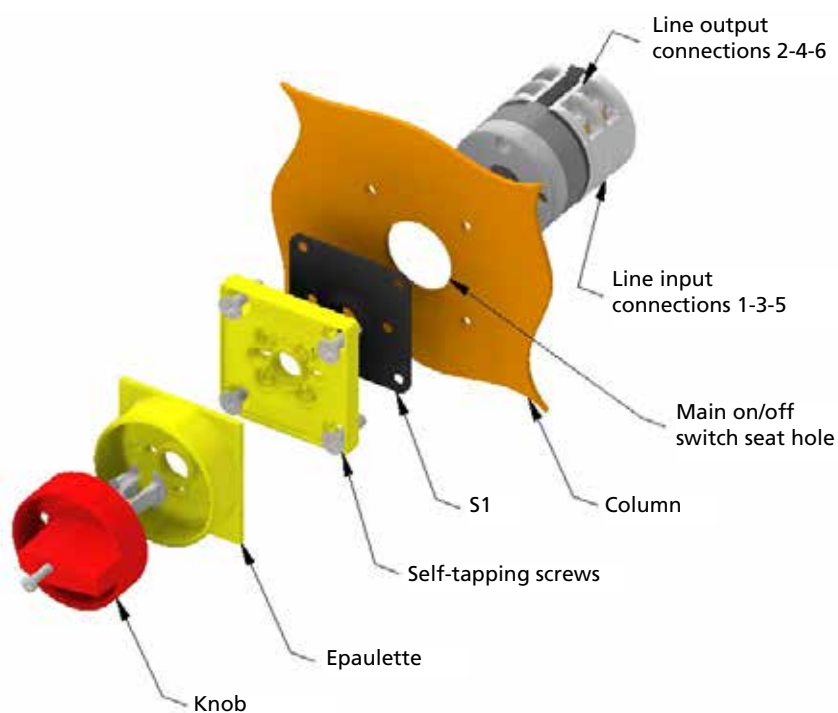

fig.58



The user or installer assigned by the user must:

- ▶ Install, in the immediate vicinity of the crane, a line switch, protected against short circuits, showing its function with the appropriate label.
- ▶ Have earthing connected, to the structure of the crane, corresponding to the handling points for this purpose (fig. 58).

4.3.9 ASSEMBLY OF THE TROLLEY/HOIST



Assembly of the trolley/hoist on the crane with a section bar:



See the "User instructions" for the trolley/hoist (if supplied), attached to this publication



In the case of a lifting unit equipped with electric traverse trolley, install the matching parts - 1 -, for the trolley limit switches, between the blocks located on the arm, fixing them with the relative screws (fig. 59).

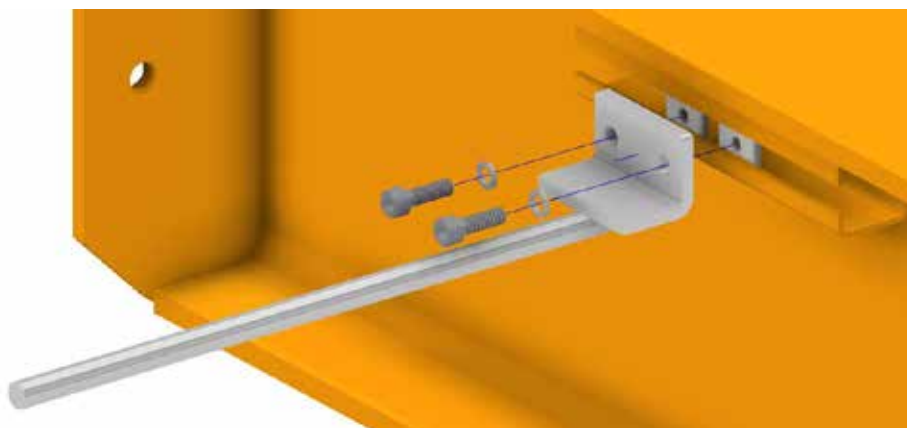

fig.59

4.3.9.1 Assemble of trolley/hoist on the profile S channel arm crane S



Assembly of the trolley/hoist on the "channel section" arm crane



1. Remove the channel profile trolleys and the connection bracket
2. Remove the block clips 1 (instructions in fig. 60) and remove the suspension pins 2
3. Insert the connection bracket inside the trolley plates. (fig. 61)
4. Reassemble the suspension pins 2 and block them with the clips 1. (fig. 61)
5. Extract the channel trolley and the related hoist from any packing
6. Remove the block clips 1 (Instructions in fig. 60) and remove the suspension pins 2
7. Insert the eyebolt (or the suspension hook) of the hoist in the trolley plate 3 or in the brake beam 4, respectively, when using a simple or double trolley
8. Reassemble the suspension pins 2 and block the with the clips 1
9. Position the hoist/trolley unit on a pallet and lift this until the leading height of the head of the channel section is reached
10. Working at a height, insert the preassembled lifting unit in the channel section and put the closing cover 5 in place, then tighten the fixing components 6



See "instructions for use", of the trolley/hoist, included in this publication

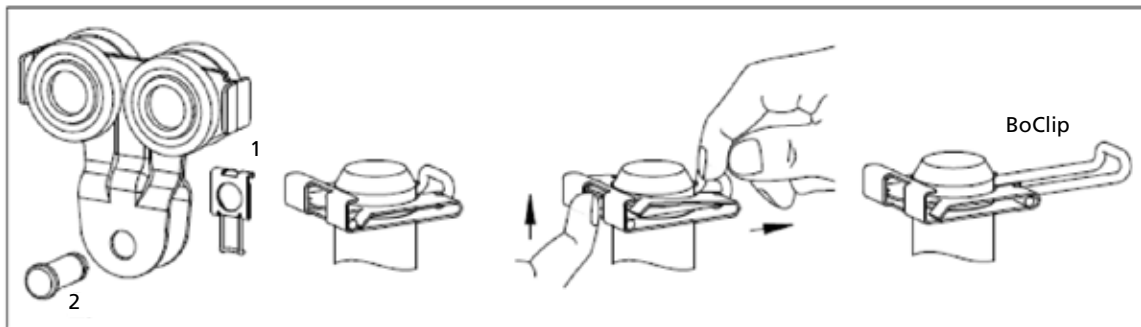

fig.60

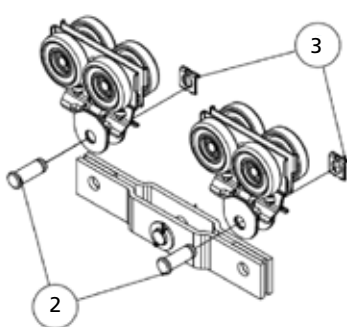

fig.61

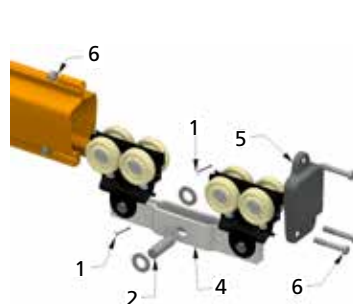

fig.62a

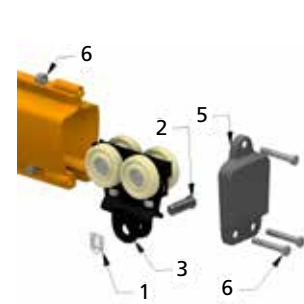

fig.62b

4.3.10 ROTATION STOPS FOR BOOMS ON GBA AND GBP (NOT PROVIDED ON CBE-MBE)

ASSEMBLY PROCEDURES | GBA type T version



To facilitate the assembly of the rotation stops, it is preferable to work with the boom at floor level.



The rotation locking device must be considered as an emergency stop system, not intended to withstand frequent impacts.

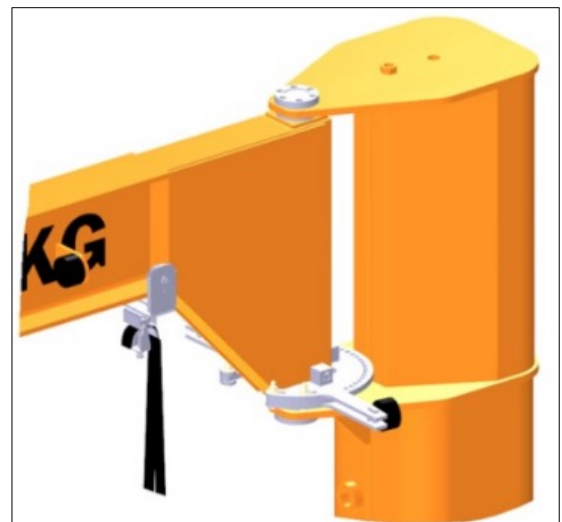
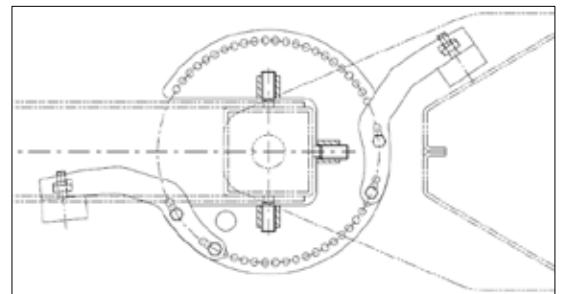
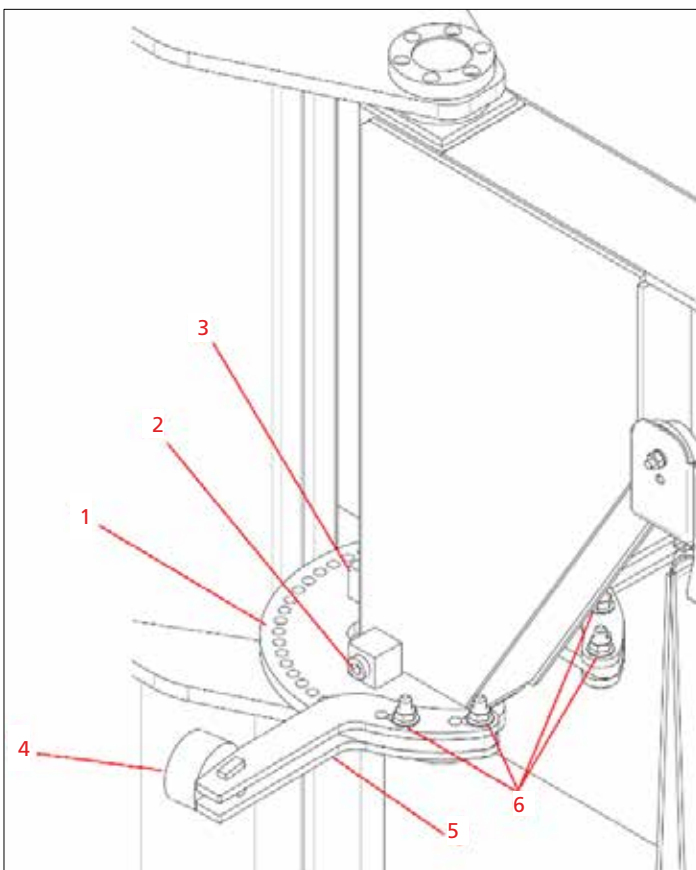

1. Remove the rotation stop kit and position the perforated disc (1) at the lower end of the side panels.
2. Insert and tighten the four side screws (2) into their respective pre-existing holes.
3. Tighten the two rear grub screws (3).
4. To determine the field of use of the boom, rotate it until it reaches the end of its travel limit (also considering the size of any equipment that will be installed on the boom).
5. Then position the buffer (4) against the column upright and fix its arm (5) to the perforated disc (1) with the screws (6) tightened to a torque of 20 Nm.

ASSEMBLY PROCEDURES | GBA type H-S version



To facilitate the assembly of the rotation stops, it is preferable to work with the boom at floor level.

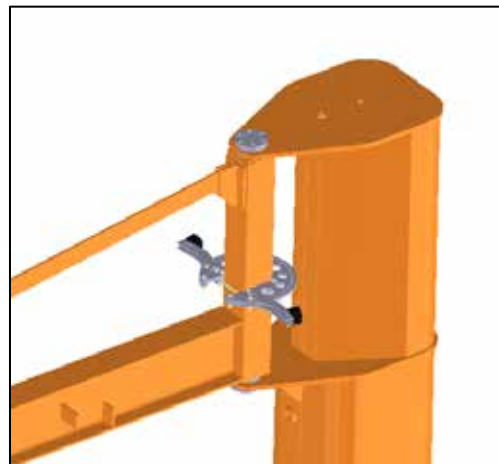
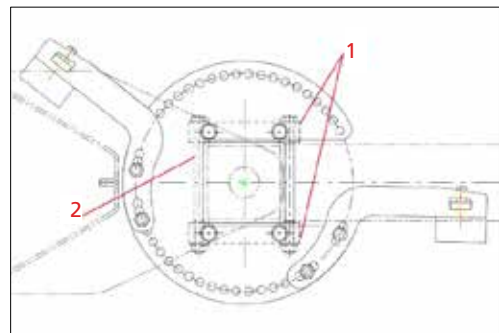
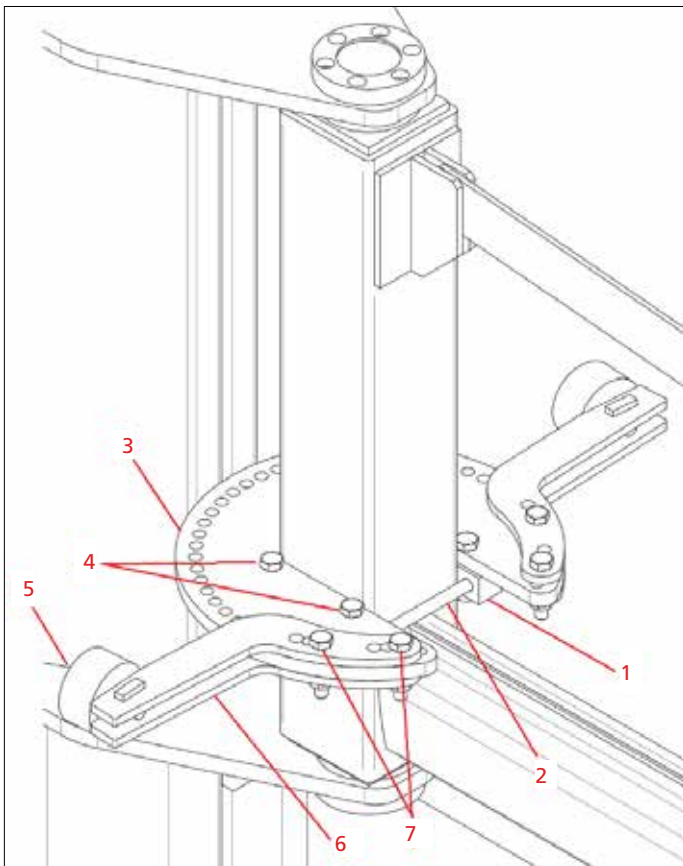

1. Remove the rotation stop kit, position the supports (1) above the beam/channel and fix them to the tube by tightening the tie rods (2) to a torque of 20 Nm.
2. Position the perforated disc (3) above the previously mounted supports and tighten it using the four screws (4) supplied to a torque of 20 Nm.
3. To determine the field of use of the boom, rotate it until it reaches the end of its travel limit (also considering the size of any equipment that will be installed on the boom).
4. Then position the buffer (5) against the column upright and fix its arm (6) to the perforated disc with the screws (7) tightened to a torque of 20 Nm.

ASSEMBLY PROCEDURES | GBP type T-H-S version



The assembly operation of the rotation stops requires the intervention of two operators.

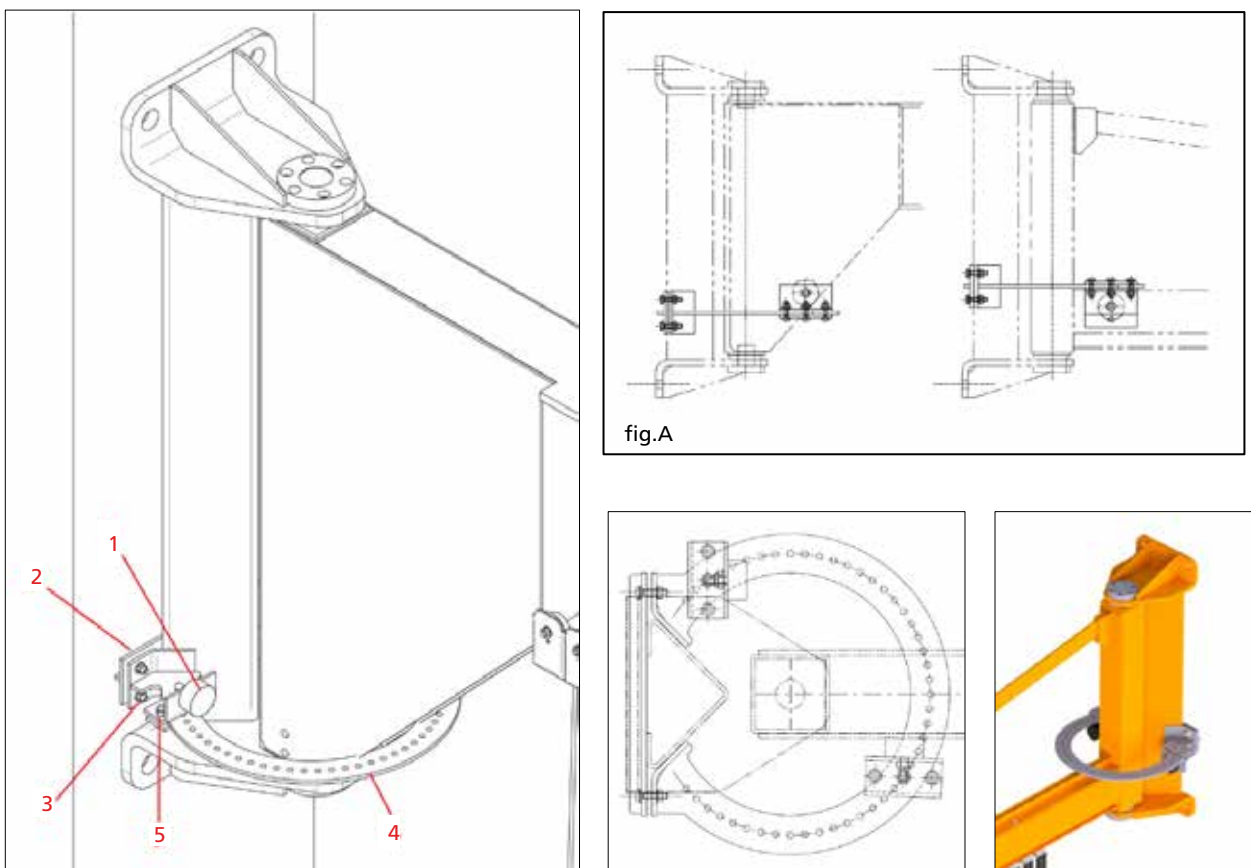

1. Remove the rotation stop kit, for its positioning level make sure that the buffer (1) has an adequate contact surface against the channel/beam (see figure A).
2. Fit the stop bracket (2) onto the upright, secure it on both sides by tightening the screws (3) to a torque of 20 Nm.
3. To determine the field of use of the boom, rotate it until it reaches the end of its travel limit (also considering the size of any equipment that will be installed on the boom).
4. Then position the buffer (1) against the boom and fix its support to the perforated disc (4) with the screws (5) tightened to a torque of 20 Nm.

4.4 COMMISSIONING

4.4.1 PRELIMINARY OPERATIONS - ADJUSTMENTS AND TEST RUNS



Before putting the jib crane into use, carry out the following operations:



▶ Check the suitability of the electrical system:

- ▶ Check that the line voltage and frequency, shown on the respective motor plates, correspond to those required for operation.
- ▶ Check that the voltage value to the motors is within the limits of +/- 10% of the rated value.
- ▶ Check for the presence and correct connection of the earth socket.

▶ Check the correct crane installation:

- ▶ Make sure that there are no clear defects after installation of the crane.
- ▶ Check that all of the bolted connections are correctly tightened.
- ▶ Check the conditions of the trolley wheel track, which must be free from obstacles, roughness, dips and foreign bodies.
- ▶ Check the uniform arm P&T sensitivity, along its entire length.
- ▶ Check the arm rotation freedom, in relation to the absence of obstacles in all of the area where the crane operates and check for any interferences.
- ▶ Adjust the electric hoist lift limit switch (see the information in the related "User instructions") in order to allow the maximum stroke possible. The lower limit switch needs to be adjusted so that the hook, in its lowest point, is 10 cm from the ground.
- ▶ Check that the matching parts are present and working for tripping the traverse limit switches, if the installation is with an electric trolley. Adjust them to prevent contact with the buffers.
- ▶ Make sure there is no lubricant leakage.
- ▶ Make sure that no noises, and/or anomalous vibrations and/or incorrect movements are detected during the tests (sliding of the wheels or spontaneous movements of the trolley and/or arm, etc.).

▶ Checking the operation of the correct rotation direction of the motors:

▶ In the case of crane with electric hoist and trolley:

- Activate the "right/left" direction buttons and check that the trolley movements occur as indicated by the direction arrows located on the crane beam;

▶ In the case of crane with electric hoist and push trolley:

- For short sections activate the "lift/lower" buttons, being careful to operate first in one direction (lower) and then in the other (lift) with two short pulses only necessary for verifying the correct rotation direction, without making any limit switches trip.



▶ First check the traverse movements, if electric, then check lifting and, in any case, prevent the lifting limit switch from tripping.

▶ If the motor rotation direction does not coincide with the pushbutton controls the limit switches will not stop their movement and may cause malfunction situations.

▶ If the movement direction does not correspond with the pushbutton panel indications, stop the movement and invert the connection of the two-line phases of the connector block.

4.4.2 ACCEPTANCE TEST OF THE JIB CRANE - SUITABILITY FOR USE



- ▶ The jib crane is put on the market considering the acceptance tests conducted at the manufacturer on similar prototypes subjected to testing of their suitability on the structural parts (columns, shelves, arms, etc.).
- ▶ The manufacturer performs a test on the manufacturing and guarantees the constant quality and the compliance to the tested prototypes of all the parts of the jib crane.
- ▶ The acceptance test procedure, described below, refers to verification of the functional and performance compliance of the jib crane installed in its place of use, complete with all its parts (anchors, structure, lifting unit, lifting accessories, etc.).
- ▶ The acceptance test of the installed crane is the responsibility of the user and must be conducted by the same specialised personnel (Installer) who performed the assembly, scrupulously following the instructions of this manual.
- ▶ The installer must perform the acceptance test and fill out all parts of the "Acceptance test report" and draft the "Suitable for use" certificate contained in the "Test logbook" attached, when included, to this publication.

After having performed the "no load" operating tests, perform the dynamic tests; these tests are performed with weights corresponding to the capacity of the crane plate plus an overload factor of 1.1 (load equal to 110% of rated load). The static tests are performed with an overload factor of 1.25 (load equal to 125% of the rated load).



All the tests must be performed when there is no wind.



To perform the acceptance test of the jib crane, proceed as follows:



No load tests:

- ▶ activate the line switch/circuit breaker
- ▶ put the emergency stop button in the "start consensus" position
- ▶ press the "start/alarm" button (if available)
- ▶ check the lift function by pressing the lift/lower buttons
- ▶ check the travel function by pressing the right/left buttons, if in electric trolley version
- ▶ if there are two speed movements check its operation
- ▶ check swinging of the arm using manual/electric rotation
- ▶ check the operation of the limit switches on all movements and/or the friction device, when available.

Dynamic test:

- ▶ prepare adequate weights for the load tests equal to **rated capacity x 1.1** and suitable equipment for slinging and lifting the load
- ▶ sling the load being careful to position the hook vertically to avoid oblique pulling
- ▶ slowly tension the sling to avoid tugging, perform the load tests using the "slow" speed if available
- ▶ slowly lift the load and check that this occurs without problems and that no anomalous noise is heard, or clear

deformation or giving way of the crane structure, support structures and/or anchorages

- ▶ repeat the test at maximum speed, if available, performing the previous tests
- ▶ check the operation of the lift/lower electric limit switches, when installed, and/or any friction device
- ▶ check the operation of the lifting brake, checking that the mass is stopped in adequate time and that there is no shifting of the load, after releasing the button
- ▶ perform the same tests also for the trolley traverse movements and arm rotation, checking the operation of the limit switches without bringing the load to the maximum height (lift to a metre from the ground).
- ▶ work first at slow speed, if available, and then at maximum speed
- ▶ check the correct movement of the trolley on the beam and make sure that no anomalous noise is heard, or clear permanent deformations or giving way of the crane structure and/or anchorages
- ▶ check the operation of the "emergency stop" button which must stop and inhibit all movements. Any operation of the hoist and/or trolley must stop, in the shortest time and space possible, without any anomalies, shifting, hazardous swinging, etc. nor compromise its stability.
- ▶ check the operation of the load limiter, and or the friction device, if included.
- ▶ check the braking and stop spaces during the lifting, traverse and rotation movements, checking the stability of the mass.



The dynamic test must be performed in the most unfavourable load conditions, i.e. by combining lifting, traverse and rotation movements.

Static test:

- ▶ prepare adequate weights for the load tests equal to: **rated capacity x 1.25** and suitable equipment for slinging and lifting the load
- ▶ sling the load **used for the dynamic tests** (rated capacity x 1.1) being careful to position the hook vertically to avoid oblique pulling
- ▶ slowly tension the sling to avoid tugging, perform the load tests using the "slow" speed if available
- ▶ lift the load and stop it in suspended position at a height of 10 cm
- ▶ gradually apply weights on it for an overload equal to 25% of the rated capacity
- ▶ leave the weight suspended for a time not less than 10 minutes.
- ▶ check that the suspended weight (load + overload) does not give way (the lifting brake and friction device/load limiter, if installed, must not slide).
- ▶ release the load and make sure that clear deformations and/or giving way of the crane and support structures and/or anchorages are not detected.



▶ **No movement of the crane should be activated during the static test.**

▶ **The jib crane acceptance test must be repeated for the annual controls (see paragraph 6.3.2).**

▶ **The annual acceptance test results must be noted in the control booklet (see chapter 8) attached to this publication, when included.**

4.5 DECOMMISSIONING

4.5.1 STORAGE AND PRESERVATION OF PARTS



If the jib crane and its components need to be stored, to prevent damage or deterioration, proceed as follows:



- ▶ Protect the machined surfaces of the plates and mechanisms with antioxidant products, do not scratch the surfaces used for assembly with other parts or inside of the holes.
- ▶ The materials, whether for indoor or outdoor installation, can be stored for a maximum period of two years in an environment with the following characteristics:
 - ▶ protected from inclement weather
 - ▶ relative humidity not greater than 80%
 - ▶ minimum temperature - 20°C - maximum temperature + 60°C
- ▶ For a storage period over two years ask the manufacturer for the storage procedures
- ▶ If during the entire storage period, these values do not comply with what is indicated, it will be necessary to perform some preliminary tests before putting the crane into service (see paragraph 4.5.2 "Ripristino dopo stoccaggio")
- ▶ If the temperature goes above or drops below the indicated values and the relative humidity is greater than 80% prepare protection packaging for the parcels with sacks and hygroscopic salts.
- ▶ Storage in outdoor areas requires:
 - ▶ wedges to lift off the floor for all parcels without pallet
 - ▶ protect all parcels with sacks and hygroscopic salts
 - ▶ if the crane has been built to operate outdoors the metal work parts do not require particular protections; on the contrary the parts machined on machine tool (machined surfaces, wheels, pins, etc.) must be protected with antioxidant products (transparent paints, grease, etc.).

4.5.2 RESETTING AFTER STORAGE



Before putting a jib crane back into operation after a long period of storage, it is necessary to perform the following operations:



- ▶ **Structure:**
 - ▶ eliminate traces of lubrication from the structure and the trolley beam
 - ▶ go over the hole threading and eliminate any grease residue
 - ▶ cleaning the matching surfaces used for assembly
 - ▶ repair any structural damage (scratched surfaces, crumbling paint, etc.)
- ▶ **Mechanisms:**
 - ▶ check for any leaks and top up lubricant levels, if necessary
 - ▶ check the correct fixing of the mechanisms to the structure
 - ▶ eliminate traces of oxidation from the accessory sliding parts of the control parts
 - ▶ lubricate the bearings and unpainted mechanical parts (shafts, pins, etc.)
 - ▶ eliminate any water residue in the concave parts

▶ **Electrical equipment:**

- ▶ eliminate any condensation from the motors and connector blocks; dry with jets of air
- ▶ check the conditions and operation of the brakes
- ▶ accurately clean the surfaces of the brakes eliminating any traces of moisture, lubricants and paints
- ▶ check the conditions and operation of the limit switches
- ▶ check the conditions of the electrical parts and components
- ▶ dry the contactor contacts
- ▶ accurately clean the closing surfaces and the threaded holes of all containers
- ▶ check the movement of the electric lines with festoons
- ▶ carefully check the operation of the control pushbutton panel

5. OPERATION AND USE OF THE JIB CRANE

5.1 FUNCTIONS OF THE JIB CRANE

5.1.1 INTENDED USE - EXPECTED USE - INTENDED PURPOSE

The **jib cranes**, with manual/electric rotation - GRL series are created to locally handle goods inside a plant, on a loading dock or along with operating stations.

Jib cranes perform three operations:

- ▶ **they lift** the load vertically in space, via a hook on the lifting unit, generally composed of a manual or electric chain hoist and using accessories suitable for this operation;
- ▶ **they traverse** the load in space, with the assistance of an electric or manual hoist holder trolley, which runs along the radial axis of the crane arm;
- ▶ **they rotate** the load in space, around the constrained axis of the arm, through a manual push action of the load using the circular area below, limited by the rotation radius of the arm.

If equipped with an **electric hoist and push trolley** movements are activated:

- ▶ **from a pushbutton panel** with “lift and lower” buttons to control the **lifting** movement.
- ▶ **by pushing** to control the **traverse** trolley.

If the crane is equipped with an **electric hoist and electric traverse trolley** movements are activated:

- ▶ **from a pushbutton panel** with “lift and lower” buttons to control the **lifting** movement.
- ▶ **from a pushbutton panel** with “right and left” buttons to control the **traverse** movement.

If the crane is equipped with a **manual hoist and trolley** movements are activated:

- ▶ **by mechanical activation** of the hoist manoeuvre chain for the **lifting** movement.
- ▶ **by pushing** to control the **traverse** trolley.

The **arm rotation** movement is activated manually by **push P&T or electrically from the pushbutton panel**.

When the controls are from the pushbutton panel, the buttons activate the function when they are pressed and the slow auxiliary speed control for lifting and traverse, can be activated as follows:

- ▶ **with separate buttons**, independently activating the “slow” speeds from the “fast” ones.
- ▶ **with a single button** with two clicks, the first click to control the “slow” speed, the second click to control the “fast” one.

The **emergency stop** button, present on the pushbutton panel is mushroom shaped, red, and activates the **stop** function when pushed all the way down.

To allow crane operation the **emergency stop** button needs to be in the “lifted” position for start consensus and then the **function buttons** need to be pressed.

The pushbutton panel is suspended from the hoist and can be operated by the operator on the ground, following the traverse movement of the trolley and/or rotation of the arm.

The electrical movements of the jib crane can also be controlled by a remote-control system: the functions of the buttons are unchanged compared to those related to the pushbutton panel.



- ▶ When the electric movements of the crane are controlled by remote control the pushbutton panel is not restricted by the crane, the operator thus must always pay utmost attention during manoeuvres without ever losing sight of the work area and the handled load in order not to compromise his safety and/or that of any exposed persons.
- ▶ It is prohibited to control the jib crane movements while on board it.

5.1.2 PERMITTED LOADS, UNPERMITTED LOADS

The loads must be:

- ▶ Of a shape, dimensions, weight, equilibration and temperature suitable for the characteristics where they need to be handled and must be compatible with the performance of the jib crane.
- ▶ Equipped with grip points and/or slung with specific accessories which prevent accidental dropping.
- ▶ Stable and not subject to changing their static or physical configuration during handling.



Handling the following loads is not allowed:

- ▶ whose weight, including any accessories, exceeds the crane capacity (fig. 63).
- ▶ with weights that are unbalanced compared to their centre of gravity.
- ▶ with surfaces that are not sufficiently resistant to the pressure exercised by the grip.
- ▶ that, due to their chemical and physical characteristics, have been classified as hazardous, for example: flammable, explosive, radioactive, etc. materials.
- ▶ toxic or harmful materials or products, if not handled in specific safe containers, for example; corrosive chemical products, with biological risks, etc.
- ▶ bulk food products or substances that can come into direct contact with the hoist parts or with its lubricants.
- ▶ that can change their static and/or chemical and physical configuration or their barycentre during handling.
- ▶ not equipped with accessories as per the following point.

5.1.3 LIFTING ACCESSORIES

The following are generally allowed:

- ▶ Slings consisting of ropes and/or chains and/or textile fibre bands
- ▶ Lifting accessories that are placed between the load and the lifting hook, such as: balances, pliers, suction cups, magnets and electromagnets, etc.
- ▶ The use of such accessories must be in compliance with the instructions supplied by their manufacturers.



The following accessories are generally not allowed:

- ▶ with functional specifications that can cause dynamic overstress to the crane greater than those allowed or accidental overloading.
- ▶ that can collide with the parts of the jib crane.
- ▶ that limit the free movement of the load.
- ▶ that are connected with independent electrical lines.



fig.63

5.2 OPERATING CONDITIONS

5.2.1 OPERATING ENVIRONMENT

The operating environment must have the following specifications:

- ▶ **temperature:** min. - 10°C; max.: + 40°C; relative humidity max. 80%.
- ▶ **use in an indoor environment:** in this case the jib crane is not exposed to inclement weather and does not require any special precautions.
- ▶ **use outdoors:** the jib crane may be exposed to inclement weather during and after use. The electrical parts of the hoist and trolley must be equipped with protection IP55, it is also recommended to protect the hoist and trolley with overhangs and guards (fig. 64)

To prevent oxidation, protect the structure with adequate treatments and lubricate rotating parts.

Outdoor use of the jib crane is permitted if there is no exceptionally bad weather, which could modify the values of the expected loads, for example heavy rain, heavy snowfall, strong wind, etc.



The crane in the standard model, must not be used in environments and areas:

- ▶ With vapours, fumes or dusts which are highly corrosive and/or abrasive (when this cannot be avoided intensify the maintenance cycles).
- ▶ In the presence of flames and/or heat greater than the allowed temperatures.
- ▶ With the risk of fire or explosion where the use of anti-explosion and/or fireproof components is required.
- ▶ In areas where strong electromagnetic fields are present which can generate electrostatic load accumulations.
- ▶ In direct contact with bulk food substances.

5.2.2 ZONE PERICOLOSE E PERSONE ESPOSTE

The danger zones are all of those where, in any operating phase, the exposed persons can be subject to the risk that an event may occur hazardous for their safety, health of psychological/physical well-being. Specifically, it is necessary to inform **potentially exposed persons**, that the operator assigned with use of the jib crane does not always work, in the movement trajectories of the **danger zones**, with sufficient visibility conditions to be able to completely and immediately prevent all potential risks of being crushed, collisions and being dragged in in terms of any people who thus must avoid to exposing themselves to risk during the manoeuvres in these areas (fig. 65).



It is mandatory for the customer to place adequate signs in the danger zones to prohibit or limit access to unauthorised and/or unassigned personnel in the areas where the jib crane works, as required by current laws.



fig.64



fig.65

5.2.3 WORK AREA LIGHTING

“Pillar” GBA-CBE and “wall” GBP-MBE jib crane series are not equipped with their own lighting system. Consequently, the workplace of the operator assigned to use the crane must be adequately lighted and ensure maximum visibility.



The level of ambient light must always be such as to ensure the maximum possible safety for crane operations (fig. 66).

It is mandatory to install supplementary lighting systems in areas that are not sufficiently lit, thus preventing shadow areas that inhibit or reduce the visibility in the operating and/or surrounding areas.

5.2.4 OPERATOR

The **operators** are all of those who carry out the following activities on the jib crane on a time-to-time basis:

- ▶ transport, handling, assembly, installation, adjustments and the acceptance test
- ▶ commissioning, use, cleaning, maintenance and repair
- ▶ disassembly, dismantling and demolition

The operators need to be persons suitable for the work and mentally and physically able to meet the needs connected with the activities correlated with the jib crane during all the operating phases and in particular during the slinging and handling phases.

The **operator assigned to use** of the cranes must position himself in a manner that is not dangerous for his safety, predicting and thus preventing possible falls or dangerous movements of the transported load. Instructions are provided below to obtain greater safety for himself and others in using the machine, specifically the instructions in the manual must be scrupulously followed.



The operator must not allow anyone to come close during the use of the jib crane and prevent it from being used by unauthorised personnel, especially minors under age 16.
 The use of the crane by unauthorised and uninformed persons is prohibited.
 The operator must always use adequate personal protection equipment (P.P.E. = gloves, protective shoes).

5.2.5 JIB CRANE CAPACITY

The **capacity** of the jib crane, in the planned operating configuration, is clearly indicated by the plate affixed on it and is visible from the manoeuvring position.



- ▶ The capacity of the crane or its accessories must never be exceeded by applying overloads (fig. 67).
- ▶ The crane must never be equipped with lifting equipment (hoist) with a rated capacity over the same.
- ▶ The lifting speed of 24 m/min must never be exceeded, unless the crane capacity is adequately reduced.



fig.66



fig.67

5.2.6 MANOEUVRES: LIFTING, TROLLEY TRAVERSE AND ARM ROTATION

It is a good idea to perform one movement at a time, since it is only in this way that a manoeuvre can be started, stopped and constantly followed by the operator, who should also avoid continuously enabling and disabling including in the case of small movements.

- ▶ Gripping of the load with the hoist hook and the lifting accessories needs to be carried out carefully, gently and without abrupt movements.
- ▶ Start the lifting operation by slowly tensioning the chain until lifting the load a few centimetres, stop the manoeuvre and check the hold and the stability of the load.

- ▶ At the end of handling, carefully place the load and release the hoist hook,
- ▶ During lifting manoeuvres, the operator must avoid putting the hook on the ground or on the loads to lift, to prevent the chain from shifting. The operator must absolutely avoid making oblique pulls which are always dangerous and hard to control (fig. 68).
- ▶ During trolley traverse manoeuvres it is mandatory to avoid violent collisions between the trolley/hoist and the end bumpers, in order not to cause serious repercussions on the mechanical parts and metalwork.
- ▶ In manual traverse and/or arm rotation manoeuvres the operator must move the load by pushing it and never by dragging it towards himself, to prevent the risk of being crushed (fig. 69).



- ▶ **Work carefully and diligently constantly following the manoeuvres and visually checking the equilibrium of the handled weight.**
- ▶ **Avoid sudden manoeuvres and “small abrupt movements” that are very damaging for the stability of the load due to the dynamic effects which are generated.**
- ▶ **Never lift loads with grips which are not barycentric and not balanced or omit to hang and secure all of the required slinging accessories or fix the load with temporary or makeshift slings.**
- ▶ **Never leave the load suspended, once a handling operation has been started, it must be completed as quickly as possible and the load needs to be placed without crushing the lifting accessories.**

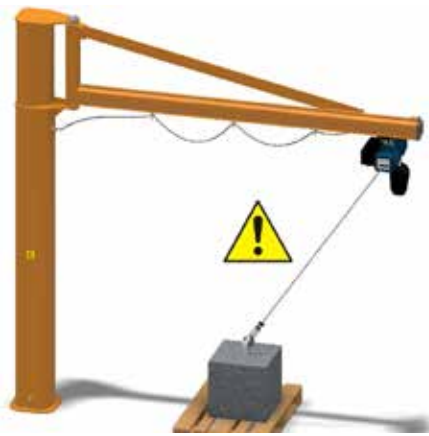

fig.68



fig.69

5.2.7 SAFETY DEVICES

Disabling of the crane power must be performed by disabling the line switch/circuit breaker (not included in the supply) and/or by pressing the “emergency stop” button on the pushbutton panel.

An electric or mechanical interlocking device prevents simultaneous control in both motor rotation directions, both at slow and fast speed.

The lack of voltage causes an immediate block of all hoist and trolley movements, since the electric motors are equipped with automatic braking devices.

A safety catch is installed on the lifting hook to prevent accidental unhooking of the slings and/or load.

The lifting, traverse and rotation limit switches limit the maximum vertical and horizontal travel of the load. They are emergency devices and not suitable as operating stops.



- ▶ **The safety devices, when excluded from the DONATI SOLLEVAMENTI S.r.l. supply must be installed by the customer.**
- ▶ **It is prohibited to put the jib crane into service and/or affix the CE marking, shown on the side, before it has been completed in compliance with the instructions contained in this point.**



5.3 ACTIVATING THE JIB CRANE



To start the operating activity of the jib crane follow the instructions below:



1. Visually inspect the conditions of the crane and the structures where it is installed.
2. Perform all of the tests as described in paragraph 5.5 – “Criteri e precauzioni d’uso”
3. Activate the power line by putting the general switch in the “ON” or “1” position
4. Check that there are no exposed persons in the hazardous operating areas
5. Put the “emergency stop” red mushroom head button in start consensus
6. Activate all of the functions by pressing the “start” button, if available
7. Check the operation of the safety devices by checking the movements as described in the paragraph 5.1 – “Functions of the jib crane”

5.4 DEACTIVATING AT THE END OF WORK



To deactivate the crane at the end of work follow the instructions below:



1. Position the arm in a recovery position making sure of its stability and taking care that it does not generate risks of collision or interferences with surrounding structures and/or machines
2. Release the lifting hook from the slings used to handle the load
3. Lift the hook, where possible, to a height not under 250 cm, i.e. so that it does not create disturbances and danger for the movement of people and things below the crane.

If used with a manual hoist:

4. Make sure the manoeuvre chain does not generate risks of being drawn in

If used with a electric hoist:

4. Stop all crane movements by pressing the “stop” button of the pushbutton panel
5. Put the pushbutton panel in the “do not disturb” position
6. Deactivate the power by putting the general switch in the “OFF” or “0” (zero) position.

5.5 CRITERI E PRECAUZIONI D'USO



▶ **The correct use of the jib crane makes it possible to fully use the performance that is able to provide in completely safe conditions.**

▶ **This potential is only guaranteed by scrupulously following the instructions below:**

- ▶ **ALWAYS** follow the indications and instructions contained in the installation and user manuals and check the conditions of the crane components and parts.
- ▶ **ALWAYS** comply with the instructions and warning shown on the machine; the warning plates on the crane and the manoeuvre areas are accident prevention warnings and they must always be perfectly legible.
- ▶ **ALWAYS** make sure that the crane works in an environment protected from inclement weather (rain, wind, snow, etc.) or, if outdoors, that it is equipped with suitable guards.
- ▶ **ALWAYS** check the compliance of the crane performance in relation to its intended service (duty cycles - intermittence - use time - load to handle) .
- ▶ **ALWAYS** check the solidity and adequacy of the structures (columns, foundations) which support the jib crane
- ▶ **ALWAYS** make sure the maintenance conditions of the crane are adequate (cleaning and lubrication) and of its main components (hook, chains, pushbutton panel, limit switches, gear motors, wheels, brakes, etc.).
- ▶ **ALWAYS** check the correspondence of trolley and hoist movements.
- ▶ **ALWAYS** test the operation of the emergency stop button.
- ▶ **ALWAYS** and constantly check the efficiency of the brakes, limit switches and electrical system.
- ▶ **ALWAYS** check the conditions of the chain, block, hook and pushbutton panel.
- ▶ **ALWAYS** check that the hook is not worn, damaged or missing its spring catch.
- ▶ **ALWAYS** check the suitability and efficiency of the slings (ropes, chains, bands, etc.).
- ▶ **ALWAYS** check that the track for movement of the trolley, is installed at a height which does not allow the operator to interfere with the shape of the trolley hoist and/or its moving parts. If this is not possible install appropriate guards or signs located in the risk area (fig. 73).
- ▶ **ALWAYS** act on the load by pushing it during manual handling and avoid pulling it towards yourself.
- ▶ **ALWAYS** make sure to have centred the lifting unit (hoist and hook), on the perpendicular axis of the load before performing the slinging and handling of the load.
- ▶ **ALWAYS** correctly secure the slings of the load to the lifting hook and tension the slings with slow and safe manoeuvres.
- ▶ **ALWAYS** work in the best lighting conditions of the area and visibility of the load.
- ▶ **ALWAYS** ensure, before any manoeuvres that arm rotation is free from obstacles and that the load does not encounter obstacles during lifting, traverse and rotation.
- ▶ **ALWAYS** work outside the manoeuvre range of the lifted load.
- ▶ **ALWAYS** activate the various movements avoiding the use of control impulses in rapid succession.
- ▶ **ALWAYS** avoid combining movements by activating the lift and traverse buttons at the same time and being careful not to generate swaying of the load.
- ▶ **ALWAYS** use the "slow" speeds for approach and positioning operation.
- ▶ **ALWAYS** position the crane arm, load hook and pushbutton panel at the end of working in a manner that they do not constitute elements of a collision risk.
- ▶ **ALWAYS** press the red emergency stop button on the pushbutton panel and disable the crane general switch before leaving the manoeuvre position.
- ▶ **ALWAYS** turn off the machine voltage for inspections, repairs and routine maintenance operations.
- ▶ **ALWAYS** use suitable personal protection equipment (PPE, gloves, etc.) for all operations
- ▶ **ALWAYS** report any operating anomalies (defective behaviour, suspected breakage, incorrect movements and noise that is not normal) to the department head and put the machine in non-working conditions.

▶ **ALWAYS** comply with the maintenance operation program and register, for each test, any observations related in particular to the hook, chains, brakes and limit switch.



fig.70



fig.71



fig.72



fig.73

5.6 USE CONTRAINDICATIONS



- ▶ The use of the jib crane for unpermitted manoeuvres, its improper use and lack of maintenance may result in serious risks for the health and safety of the operator and exposed persons, as well as compromise the operation and safety of the machine. 
- ▶ The actions described below, which obviously cannot cover the entire range of possible "misuses" of the crane, however constitute those which are "reasonably" more predictable, they are absolutely prohibited and therefore:

5.6.1 UNINTENDED AND UNPERMITTED USE - PREDICTABLE AND UNPREDICTABLE INCORRECT USE

- ▶ **NEVER** use the jib crane to lift and transport people (fig. 88).
- ▶ **NEVER** lift loads greater than the rated capacity nor equip the crane with hoists with a rated capacity higher than the crane capacity (fig. 74).
- ▶ **NEVER** lift loads while people are transiting in the manoeuvring area below.
- ▶ **NEVER** move through, stand, work or manoeuvre under the suspended load.
- ▶ **NEVER** allow the crane to be used by unauthorised personnel or minors under 18 years of age.
- ▶ **NEVER** use the crane if not mentally and physically fit.
- ▶ **NEVER** use the crane without adequate personal protection equipment (PPE, gloves, etc.).
- ▶ **NEVER** operate without due attention during load lifting and traverse and arm rotation manoeuvres.
- ▶ **NEVER** rotate the load and/or crane arm and/or drag the push trolley using the pushbutton panel cable.
- ▶ **NEVER** put your hands on the slings during the "tensioning" phase in the contact areas with the load and between the hook and slings.
- ▶ **NEVER** leave a suspended load unsupervised.
- ▶ **NEVER** use the crane for services other than those for which it is intended, avoid using it for other operations for example painting ceilings, changing light bulbs, as a support for scaffolding, etc.
- ▶ **NEVER** lift unbalanced loads.
- ▶ **NEVER** swing the load or the hook during the traverse and/or rotation.
- ▶ **NEVER** put the chain in a diagonal pull position.
- ▶ **NEVER** use the crane or its lifting equipment for pulling or dragging operations.
- ▶ **NEVER** use slings without having previously checked their suitability.
- ▶ **NEVER** use the hoist chain as earthing for the welding machine.
- ▶ **NEVER** lift loads with the tip of the hook.
- ▶ **NEVER** use the crane to keep items attached to the ground tensioned or to extract them.
- ▶ **NEVER** lift "guided" loads without having set up adequate safety measures.
- ▶ **NEVER** continue the hook stroke after having placed the load causing the chain to shift.

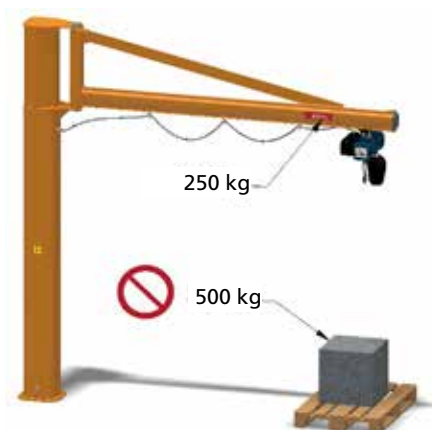

fig.74

- ▶ **NEVER** bump into the plant structures, machines and systems with the load or arm.
- ▶ **NEVER** use two cranes at the same time to lift the same load (fig. 75).
- ▶ **NEVER** use the crane with two simultaneous movements, wait until the movement in progress has completely stopped before starting another one.
- ▶ **NEVER** use the crane in unpermitted environmental conditions or, if installed outdoors, in harsh, unfavourable and/or dangerous environmental conditions (strong wind, heavy rain, etc.) - (fig. 76).

- ▶ **NEVER** use or work on the crane in insufficient lighting and/or visibility conditions.
- ▶ **NEVER** use the crane in areas where the use of non-explosive components is required.
- ▶ **NEVER** make the limit switches or load limiter trip continuously.
- ▶ **NEVER** reach the "stroke end" areas at full speed in traverse and rotation movements.
- ▶ **NEVER** use the crane in the presence of a sharp mains voltage drop or if one of the three phases is missing.
- ▶ **NEVER** perform abrupt changes in direction in the lifting, traverse and rotation manoeuvres.
- ▶ **NEVER** repeatedly activate the pushbutton panel control buttons.
- ▶ **NEVER** change the functional and performance characteristics of the crane and/or its components.
- ▶ **NEVER** tamper with the settings of the safety devices (limit switches, clutch device - (fig. 77)
- ▶ **NEVER** perform temporary repairs or reset interventions not in compliance with the instructions.
- ▶ **NEVER** use non-original spare parts or those not prescribed by the manufacturer.
- ▶ **NEVER** entrust extraordinary maintenance and repair operations to personnel not instructed by the manufacturer.
- ▶ **NEVER** leave the crane at the end of work without having put the safety procedures into place (fig. 78).
- ▶ **NEVER** perform, maintenance, inspections or repairs without turning off the crane.
- ▶ During maintenance phases, **NEVER**:
 - ▶ use unsuitable tools
 - ▶ lean ladders on the column, hoist, trolley or crane arm
 - ▶ work without personal protection equipment
 - ▶ intervene without having removed the lifted load
- ▶ **NEVER** use the crane if it is not perfectly compliant in all its operating functions.



fig.75



fig.76



fig.77

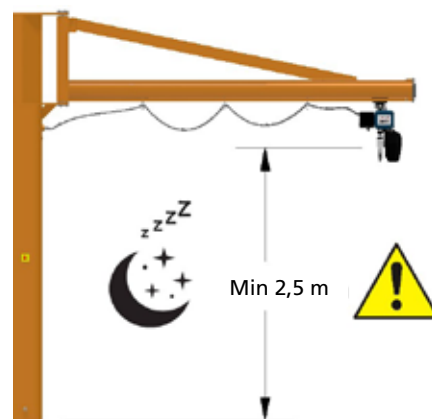

fig.78

6. JIB CRANE MAINTENANCE

6.1 SAFETY PRECAUTIONARY MEASURES

The accident prevention measures contained in this section must always be strictly observed during maintenance to avoid injury to workers and damage to the crane.



The personnel assigned to jib crane maintenance must:

- ▶ be well trained
- ▶ have read this publication
- ▶ have an in-depth knowledge of accident prevention laws
- ▶ unauthorised personnel must remain outside of the work area during operations

These measures are cited and further described in this chapter, each time a procedure is required that may entail a risk of injury, damage or accident, using the **WARNING** and **HAZARD** notes:



The **WARNING** notes precede an operation that, if not correctly performed, may cause damage to the crane or its components.



The **HAZARD** notes precede any operation that, if not correctly performed, may cause an operator accident.



Pay attention to the following **WARNING NOTES** during the maintenance phases:



Before restarting the jib crane, after a fault, it must be carefully inspected and controlled to discover any damage and the procedure described in paragraph 5.3 must be repeated.



Never intervene on the setting and positioning of safety devices unless expressly required to eliminate a fault. Tampering with them may cause serious damage to the crane or its components.



Pay attention to the following HAZARD NOTES during the maintenance phases:



Disable the power to the crane electrical components before performing maintenance operations unless the power is necessary. Affix a sign stating: MACHINE MAINTENANCE - DO NOT TURN ON THE POWER.



Never disable the safety and protection devices installed on the jib crane. Use specific warning signs if it becomes necessary and work with utmost caution.



Always make sure of the presence and suitability of the earth connections and their compliance with the law. Lack of an earth connection for the electrical equipment may cause serious injury to people.



Avoid the use of flammable or toxic solvents (petrol, ether, alcohol, etc.).
Avoid prolonged contact with solvents and inhalation of their fumes.
Specifically avoid use near open flames.



Always ensure, before starting the crane, that the personnel assigned to maintenance is at a safe distance (no longer above ground) and that tools and materials have not been left on the crane.



Always use protective gloves during maintenance operations.



All the accessible moving parts, with the sole exception of the chain and subblock/block, are protected against accidental contacts as much as possible. Replace the required guards before starting the crane again.



Never use sprayed water for fires, disconnect all the power and use adequate fire extinguishers.



Make sure that the tools to use are in perfect conditions and have insulated handles, where required.



Pay maximum attention to all the RESIDUAL RISKS shown on the jib crane and included in this publication.

6.2 QUALIFICATION OF PERSONNEL ASSIGNED TO MAINTENANCE

To be able to adequately perform maintenance of the jib crane, the personnel assigned to maintenance must:

- ▶ know the current laws related to accident prevention during the work performed on the machines with motor transmission and be able to apply them
- ▶ have read and understood chapter 3 - "SAFETY AND ACCIDENT PREVENTION"
- ▶ know how to use and consult this documentation
- ▶ be interested in the machine operation
- ▶ notice any operating irregularity and take the necessary measures if needed

The professional figures in charge and authorised to perform crane maintenance are:



Operator assigned to use of the jib crane



▶ Typical maintenance activities:

- ▶ testing of correct operation of the jib crane. Collaboration with the personnel assigned to routine and/or extraordinary maintenance, after prompt notification of the same if anomalies are discovered
- ▶ cleaning and lubrication of the crane parts (hoist) with which they are normally in contact (pushbutton panel and hook) and performance of simply performed maintenance activities which do not require overhead interventions (e.g. hook thrust bearing lubrication)

▶ Required technical knowledge:

- ▶ knowledge of the functions and use of the jib crane
- ▶ knowledge of the lubricant used in the crane and hoist and the hazards connected with their use

▶ Required qualification:

- ▶ suitable for work in relation to the specific operating and environmental characteristics



Mechanical maintenance personnel



▶ Typical maintenance activities:

- ▶ mechanical adjustment of brake and mechanism clearances
- ▶ testing of performance of movements and mechanical adjustment of safety devices
- ▶ checking of mechanical clearances and component (chain, hook, etc.) wear
- ▶ replacement of worn components (chain, hook, chain guide, pulleys) through the use of this publication
- ▶ routine maintenance of the mechanical units after replacement of parts with original spares

▶ Required technical knowledge:

- ▶ good knowledge of the mechanical lifting and manual and motor handling systems
- ▶ good knowledge of the safety devices used in the hoist (limit switch, brakes, load limiter, clutch, etc.)
- ▶ elementary knowledge of moderately difficult electrical setting and control techniques (limit switch adjustment, fuse replacement, motor connections, etc.)
- ▶ knowledge of the measurement and test methods to determine the actual state of the crane and hoist conditions (testing of: brakes, wear on chain and hook wear, wheel wear, anomalous noise, etc.)
- ▶ non-complex logical troubleshooting methods and result assessment
- ▶ ability to organise the measurements aimed at restoring the hoist operation and performance
- ▶ ability to write a maintenance intervention report

▶ Required qualification:

- ▶ Complete training as an industrial mechanic with specialisation and experience in maintenance of lifting or industrial handling systems



Electrical maintenance personnel



▶ Typical maintenance activities:

- ▶ intervention on electrical equipment starting from functional diagrams
- ▶ testing of performance of movements and electrical adjustment of safety devices
- ▶ testing of wear of electrical components (contacts of electrical equipment)
- ▶ repair of electrical units after replacement of parts with original spares

▶ Required technical knowledge:

- ▶ good knowledge of electrical systems and installations
- ▶ good knowledge of electrical components and safety devices used in the hoist (limit switch, brakes, etc.)
- ▶ knowledge of average difficult electrical control and adjustment techniques (replacement based on the original diagram of: motors, limit switch, pushbutton panel, control panels, cables, etc.)
- ▶ elementary knowledge of moderately difficult mechanical control and adjustment techniques (testing of wear, adjustment of mechanical stops, etc.)
- ▶ knowledge of the measurement and test methods to determine the actual state of the hoist conditions (testing of the efficiency and reliability of the electrical equipment)
- ▶ knowledge of electrical troubleshooting methods and experience on electrical command and control systems for lifting and handling equipment
- ▶ ability to organise the measurements aimed at restoring the hoist operation and performance
- ▶ ability to write a maintenance intervention report

▶ Required qualification:

- ▶ Complete training as an electrical mechanic with specialisation and experience in maintenance of lifting or industrial handling systems



Electromechanical maintenance personnel:
operator whose professional profile, in addition to possessing the typical characteristics of electrical maintenance personnel, also possesses the skills and technical abilities required of mechanical maintenance personnel



Mechanical technician



▶ Typical technical activities:

- ▶ mechanical adjustments of safety devices, calibrations and acceptance tests (annual load tests)
- ▶ routine maintenance operations after replacement of complex mechanical components and/or those which are critical for safety purposes (anchoring components, arm, gear motors, motors, etc.)
- ▶ repair of mechanical units after extraordinary maintenance operations (repair of structural parts with welding, mechanical machining on the crane, etc.)

▶ **Required technical knowledge:**

- ▶ knowledge of lifting and industrial handling mechanical systems certified by specific training
- ▶ specific knowledge of the safety devices used in the hoist (limit switch, brakes, load limiter, clutch, etc.)
- ▶ basic knowledge of electrical control and adjustment techniques (testing of motors)
- ▶ specific competence in measurement and test methods for determining the actual state of the crane and hoist conditions (testing of: brakes, pushbutton panel, control panel, limit switch, etc.)
- ▶ specific competence on logical troubleshooting methods and result assessment
- ▶ ability to oversee the measurements aimed at restoring the jib crane operation and performance
- ▶ ability to write a maintenance intervention report

▶ **Required qualification:**

- ▶ Complete training as an industrial mechanic technician with specialisation and specific competence in lifting and handling systems



Tecnico elettrico



▶ **Typical maintenance activities:**

- ▶ electrical adjustments of safety devices, calibrations and acceptance tests (annual load tests)
- ▶ routine maintenance operations including replacement of complex electrical components and/or those which are critical for safety purposes (lifting limit switch, motors, LV panel)
- ▶ repair of electrical units after extraordinary maintenance operations (repair of electrical motors with partial replacements, replacement of limit switch with changes in layout, etc.)

▶ **Required technical knowledge:**

- ▶ excellent knowledge of electrical systems and installations on lifting and industrial handling equipment
- ▶ specific knowledge of electrical components and safety devices used in the hoist (limit switch, brakes, load limiter, etc.)
- ▶ experience with electrical control and adjustment techniques (ability to intervene on the original diagram for improvements on; limit switch, pushbutton panel, control panels, cables, etc.)
- ▶ knowledge of mechanical control and adjustment techniques (testing of wear, testing of mechanical component performance, adjustment of mechanical stops, noise testing, etc.)
- ▶ specific competence on the measurement and test methods to determine the actual state of the hoist conditions (testing of the efficiency and reliability of the electrical equipment)
- ▶ specific competence on the logical troubleshooting methods and risk assessment on the command and control electrical equipment of lifting equipment
- ▶ ability to oversee the measurements aimed at restoring the crane and hoist operation and performance
- ▶ ability to write a maintenance intervention report

▶ **Required qualification:**

- ▶ Complete training as an industrial electrical technician with specialisation and specific competence in the electrical equipment of lifting and handling systems



Electromechanical technician: operator highly specialised and specifically trained, whose professional profile includes, in addition to the typical competences and knowledge of an electrical technician, those of a mechanical technician



Special recommendations regarding maintenance:

1. If correctly performed, maintenance operations guarantee the safety of workers assigned to use of the jib crane and reduce downtime after a fault to a minimum.
2. A promptly executed repair avoids additional deterioration of the crane or its components
3. Use original spare parts and products
4. The following instructions need to be complied with for maintenance work:
 - ▶ Personnel assigned to perform routine and extraordinary maintenance work must have read and clearly understood all of the indications contained in this chapter and chapter 3
 - ▶ Extraordinary maintenance jobs must only be performed by authorised and qualified personnel who have been trained for this purpose



Maintenance operations must be performed, when possible, with the crane power off and in safe conditions, using suitable equipment and adequate personal protection equipment, based on the requirements of current laws, and affixing a sign with the warning: "MACHINE MAINTENANCE".



For any problems which should arise or to order spare parts contact the DONATI SOLLEVAMENTI S.r.l. Technical Assistance Service

6.3 MAINTENANCE PLAN

The maintenance plan includes all ordinary type operations, that entail inspections, tests and checks conducted by the operator assigned to use of the crane and/or qualified personnel assigned to normal company and periodic type maintenance which include replacement, setting and lubrication operations performed by technical personnel instructed for the purpose through specific courses or publications.



- ▶ Since maintenance operations can be performed at a dangerous height above ground, the assigned personnel must have appropriate means (scaffolding, platform, ladders, etc.) that make it possible to perform the activity in safe conditions.
- ▶ Personnel must also be in possession of adequate personal protection equipment (P.P.E.) required by current laws.

6.3.1 DAILY AND ROUTINE MAINTENANCE

This involves maintenance operations that can be directly performed by the operator assigned to use the crane or qualified personnel, as prescribed in this publication and/or in any attached documents, which do not require the use of special instruments and equipment.

Maintenance operations are divided into:



Daily operations, handled by the operator assigned to crane use:



- ▶ general visual inspections
- ▶ functional tests with testing of motors, limit switches, clutch device, brakes with no load, "stop" button, and other functions of the pushbutton panel
- ▶ testing of the chain and hook conditions
- ▶ testing of correct crane arm rotation

Monthly operations, handled by qualified personnel:



- ▶ visual inspection of each mechanism and for lubricant leaking
- ▶ functional testing of full load brakes
- ▶ checking that no anomalous noises and/or vibrations exist
- ▶ greasing of the mechanisms and limit switches to ensure regular operation and limit wear
- ▶ testing of the operation and conditions of the pushbutton panel and relative cable

Quarterly operations, handled by qualified personnel:





































- ▶ check the efficiency and wear of: hook, chain and chain guide
- ▶ check the nut, block/subblock wear
- ▶ check the wheel, pinion, guide roller of the traverse trolley wear
- ▶ check the efficiency and operation of the load limiter.
- ▶ inspect the interior of the panels to check for the presence of dust
- ▶ check and clean oxidised contacts and any plug/socket connectors
- ▶ check the greasing of the mobile trolleys of the cable line and check the cables
- ▶ check the efficiency and conditions of the power line and its components
- ▶ test the motors and brakes with load with check of wear
- ▶ check the efficiency and preservation of the structure (paint, oxidation, etc.)

6.3.2 FREQUENCY AND DEADLINES FOR MAINTENANCE INTERVENTIONS

The frequency of the following operations refers to a jib crane used in normal operating conditions and are valid up to service group M5 (standard ISO 4301/86) or 2m (FEM 9,511 rule). If the use of the jib crane is normal and correct for a daily 8 hour shift, the following overhaul may be performed after a use period of approximately 10 years (FEM 9,755 - S.W.P. rule) If use is over various shifts, the maintenance periods need to be reduced proportionately.

Table of periodic checking and maintenance operations

Subject of the check ▼	Periodic checks				Useful notes
	Daily	Monthly	Quarterly *	Annual *	
Checks Inspections - Acceptance tests	General visual checks. Correct operation 	General visual inspections 	Check wear  	Annual acceptance test  	pag. 42
Warnings and pictograms, Signs and plates	Legibility of warnings and pictograms, signs and plates 	Inspections of conditions and cleaning of plates and signs 	Check suitability  		pag. 21
Structural elements Welding - Pins Bolted connections				Check wear and efficiency Check bolted/welded 	pag. 67
Chain Anchoring parts	Visual inspection 		Check wear and efficiency 		Hoist manual
Lifting hook	Visual inspection and check spring catch 		Check wear and efficiency 		Hoist manual
Loading nut Chain guide Block return			Check wear and efficiency 		Hoist manual
Lifting gear motor Traverse gear motor Rotation gear motor		Noise test 			Hoist manual
Lifting motor Traverse motor Rotation motor	Check correct operation 		Load test 		Hoist manual
Lifting brake Traverse brake Rotation brake	Check correct operation 	Load tests Check wear 	Load tests Check wear 		Hoist manual
Wheels and pinions Guide roller Rotation bearings			Check wear 		Manuale paranco
Trolley buffers Jib anti-collision	Visual inspection 			Check wear and efficiency 	Hoist manual
Electrical system Pushbutton panel and cable	Check correct operation 	Inspection of external pushbutton panel/cable 	Check wear and efficiency 		Hoist manual
Load limiter Clutch device			Load test 	Check calibration 	Hoist manual
Lifting limit switch Traverse limit switch	Check correct operation 		Load tests Check wear and efficiency 		Hoist manual
Cleaning and lubrication	Check correct cleaning and lubrication conditions 	General lubrication inspection 	Check for chain, hook and mechanism lubrication leaks 		Hoist manual

* The following operations must be noted in the specific control booklet (See chapter 8)

6.3.3 TEST OF PART AND COMPONENT EFFICIENCY



The following instructions should be scrupulously complied with for the single parts of the jib crane:



Annual test of the efficiency of the structural elements, welding, pins and bolted joints (fig. 79):



- ▶ The metallic structure of the jib crane, in addition to normal alterations due to environmental factors and wear of moving parts, may be subject, including unexpectedly or during handling operating phases, to collisions, contacts or scraping with other equipment or abnormal stress that can damage the metalwork frames, welding and pins. Therefore, the structures, after perfect cleaning, must periodically undergo scrupulous tests to check their suitability and repair any damage if necessary.
- ▶ The brackets composed of plates and pin, that form the hinged parts are subject to wear since they are mobile and swinging parts subject to radiating friction in the contact area. Replace them if any excessive wear is found when they are checked.
- ▶ All of the grub screws, high resistance pins and pins must be disassembled and carefully checked along with their seats on an annual basis.
- ▶ Make sure the locking torque of the bolts fixing the column or shelf is in accordance with the required torques.



Repair the hinged structures and parts or replace them if the following occurs:



- ▶ **deformations:** lengthening, crushing, dents, bends
- ▶ **wear:** worn parts, reduction in cross section, incisions, abrasions, corrosion, oxidation, scratches, peeling paint
- ▶ **breakages:** cracks in the welding, bending, cuts or incisions, broken parts
- ▶ **changes in cross section \geq of 10%, or diameter or thickness \geq of 5 % compared to the initial values**

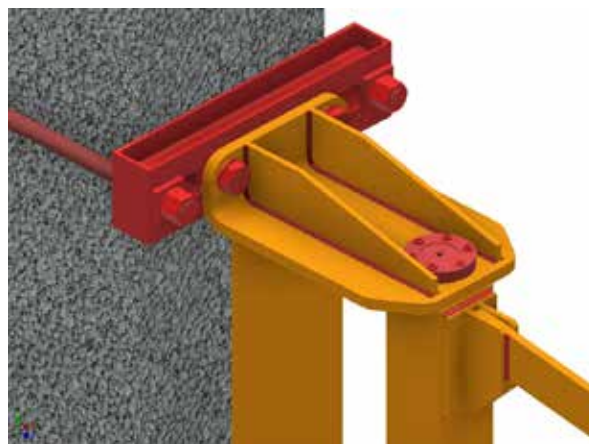

fig.79



Quarterly check of the efficiency of the channel profile trolley wheels (fig. 80):

- ▶ Check the wear of the rolling band of the wheels
- ▶ Check the ball bearings. They need to be replaced if there is excessive noise or if they have excessive friction, "tugging", difficult and/or irregular rotation



Replace the wheels if:

- ▶ The rolling diameter of the wheel has wear \geq of 5 mm
- ▶ The rolling diameter of the guide roller has wear \geq of 2 mm
- ▶ If even just one wheel needs to be replaced, to obtain the best operating guarantee and duration it is advisable to replace all of the trolley wheels



Annual check of the efficiency of the trolley buffers: (fig. 81)

- ▶ Check that the end stops are not deformed and that there are no signs of their anchoring to the structures giving way and that the buffer is intact and correctly fixed in its mounting



Replace the buffers if they have:

- ▶ Signs of breakage or permanent deformation, cuts, abrasions or incisions

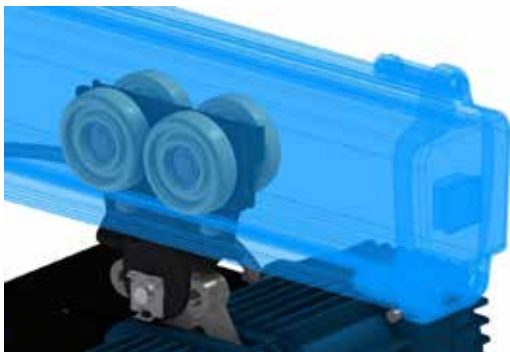

fig.80



fig.81



Quarterly check of the efficiency of the brake of the rotation arm of the crane:



- ▶ Check the stability of the arm when empty and when fully loaded, at the end points and intermediate points of rotation; then checking that the arm, in any point of the rotation, keeps its position with moving spontaneously.
- ▶ When necessary have the brake of the crane adjusted, as described in paragraph 6.4.1 – “Adjusting the rotation brake of the crane arm”, on page 80.



- ▶ Replace the clutch plates of the brake when there is instability of the arm after adjusting the brake



IN CASE OF ANOMALIES:

- ▶ It is forbidden to carry out corrective maintenance work on the brake of the rotation arm of the jib crane.
- ▶ Any operation, outside normal maintenance, on the brake of the rotation arm of the crane can be done by the assistance service of DONATI SOLLEVAMENTI S.r.l or by staff authorized by them.



Quarterly test of the efficiency of the power electrical system:



- ▶ Check the efficiency of the power cable, make sure there are no worn patches, cuts, abrasions or other alterations of the protection sheathing.
- ▶ Check the tightening of the conductors, power cable, and their terminals (in the connector block) and, if necessary, tighten them correctly.
- ▶ Check the efficiency of the conductors and earth connections, checking them and fixing all of the earthing screws if necessary.
- ▶ Check all of the seals of the covers and grommets.
- ▶ Check for the presence and efficiency of the warning plates located on the cover.



- ▶ Do not hesitate to replace the electrical component in question, if it is no longer able to offer sufficient guarantees on its functional reliability.
- ▶ Do not ever make temporary or makeshift repairs.
- ▶ Use original spare parts only.



For information on the tests of all the structural, mechanical and electromechanical components of the living and traverse units incorporated in the jib crane, see the relative documentation attached to this technical publication.



- ▶ Do not hesitate to replace the part and/or component in question, if it is not able to offer sufficient guarantees on its safety and/or functional reliability.
- ▶ Do not ever make temporary or makeshift repairs!

6.3.4 CLEANING AND LUBRICATING THE JIB CRANE



- ▶ **Cleaning can be performed by personnel who is not highly specialised.**
- ▶ **It is periodically necessary to keep the following parts clean:**
 - ▶ **jib crane structure** (column, arm, etc.)
 - ▶ **jib crane mechanisms** (thrust bearing, pins, etc.)
 - ▶ **jib crane electrical parts** (festoon cable, etc.)
 - ▶ **components of the lifting and traverse unit** (wheels, chain, hook, block, pushbutton panel, etc.)
- ▶ **Overhead cleaning above ground be performed by qualified personnel equipped with suitable means and personal protection equipment.**
- ▶ **These operations are necessary on a quarterly basis to permit activation of periodic tests.**



- ▶ Cleaning can be implemented simply with the use of means, equipment and cleansers or solvents normally used in general cleaning operations for industrial equipment since no particular contraindications exist in relation to the use of products or materials.
- ▶ Clean by removing any foreign and dirty substances with vacuums, absorbent cloths, etc.
- ▶ Dry any excess grease and/or oil on the parts.



Accurate management of the jib crane mechanism lubrication is a necessary condition for guaranteeing the effective compliance to its intended service as well as its duration.



- ▶ The lubricating power decreases over time due to stress, so it is necessary to restore or renew the lubricants.
- ▶ Lubrication of the jib crane is simple and limited to application of a thin layer of oil or grease, between the bearings and pins, in the arm rotation points.
- ▶ Instead, the lubrication of the lifting and traverse mechanisms is very important, their lubrication cycles are contained in the relative technical publications attached hereto.



- ▶ **Lubricants, solvents and detergents are toxic/harmful products for health:**
 - ▶ **they can cause irritation if they come into direct contact with the skin**
 - ▶ **they can cause serious intoxications if inhaled**
 - ▶ **they may be fatal if ingested**
- ▶ **Handle with care using adequate personal protection equipment (PPE).**
- ▶ **Dispose of correctly in compliance with current laws on toxic/harmful waste.**

6.4 ADJUSTING AND REGULATING

6.4.1 ADJUSTING THE ROTATION BRAKE OF THE CRANE ARM

REMAINING RISKS IF ON THE CRANE DURING THE ADJUSTMENT OF THE BRAKE



DANGER / RISK	BAN / WARNING	OBLIGATION / PREVENTION
 <p>Risk of crushing in case of contact with the rotation arm when adjustments of the brake are being made</p>	 <p>Warning! Exposure to moving parts can cause danger</p>	   <p>Adjustments of the brake must be carried out by qualified maintenance staff Use of protective gloves and, if necessary, safety harnesses</p>

 ▶ The brake of the jib crane must be adjusted so as to guarantee the stability of the arm in any of its positions with a maximum load.

▶ The braking is mechanical and is ensured by two pushed clutch plates which with adjusting screws work on a pressure plate, in contact with the rotation tube of the arm.

▶ The clutch plates, which are asbestos-free, are subject to wear in relation to the intensity of service and when, after a period of use, there is a tendency of the arm to take up preferred positions putting itself in different positions to those required when the rotation action has not happened, adjustment must be made.

 To adjust the brake of the arm of the jib crane proceed as follows:
WARNING! When this operation is carried out at a height, on a scaffolding or other mobile equipment, the use of safety harnesses is obligatory.

1. Regulate the slidability of the rotation of the arm, using the braking system by means of the adjuster screws 1, until you obtain the required flexing sensitivity (fig. 82).
2. Carry out the check of planarity of the arm with the help of a level. Carry out such a check rotating the arm by 90° to the left and to the right (fig. 83).

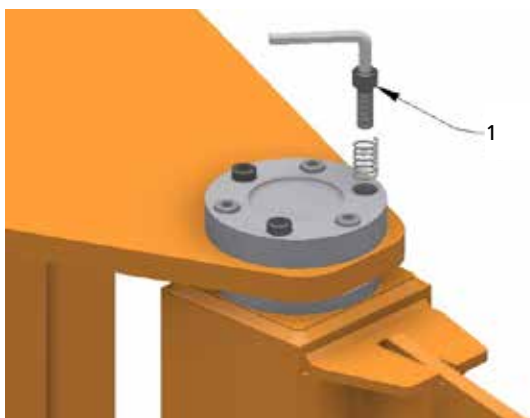

fig.82

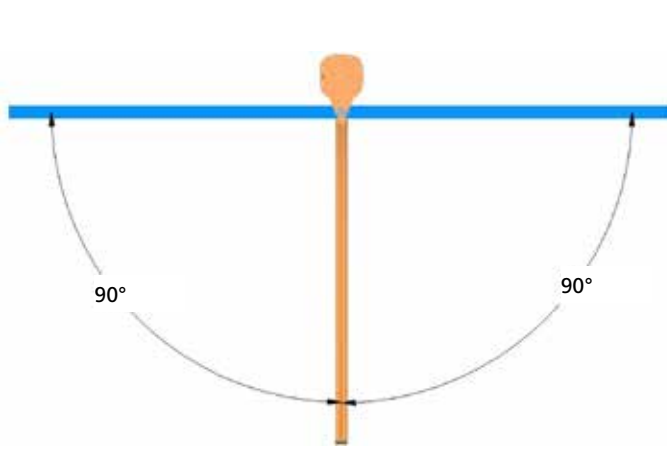



fig.83

 If the adjustment of the brake has been made several times and after the last adjustment the stability of the arm is not guaranteed, replace the clutch plates.

6.5 TROUBLESHOOTING

6.5.1 MAIN CAUSES OF MALFUNCTIONS OR FAULTS AND POSSIBLE SOLUTIONS

The columns of the table below show the main malfunction conditions that can be reasonably predicted and the type of problem, potential cause of the fault and possible solutions.

FAULT TYPE	POSSIBLE FAULT CAUSES	POSSIBLE SOLUTION
Rotation is blocked	<ul style="list-style-type: none"> ▶ introduction of a foreign object in the rotation system ▶ thrust bearing seized ▶ gear motor fault 	<ul style="list-style-type: none"> ▶ remove the foreign object ▶ replace the thrust bearing ▶ contact technical assistance
Difficult rotation Excessive force	<ul style="list-style-type: none"> ▶ drain lubrication from thrust bearing ▶ gear motor fault 	<ul style="list-style-type: none"> ▶ lubricate ▶ contact technical assistance
Arm positioning instability	<ul style="list-style-type: none"> ▶ excessive inclination of rotation axis 	<ul style="list-style-type: none"> ▶ check the verticalness of the crane and tightening of fixing system

6.5.2 PERSONNEL AUTHORISED TO INTERVENE IN THE EVENT OF A FAILURE

The personnel authorised to work in most of the cases of fault, or unless otherwise reported, is an expert maintenance person or one who is authorised based on specific preparation on the mechanical and electrical parts. When highlighted the intervention of specialised or specifically trained personnel or the manufacturer's technical personnel is necessary.

6.5.3 DECOMMISSIONING

If it is not possible to repair the jib crane, decommission it, indicating the fault with a specific sign; ask for intervention from the assistance service.

6.6 DISASSEMBLY, DISPOSAL AND SCRAPPING



If the jib crane and its components, because broken, worn or at the end of their expected life cycle, can no longer be used or repaired, they need to be demolished.



- ▶ Demolition of the jib crane must be performed using suitable equipment selected in relation to the material on which to intervene (e.g. shears, blow torch, hacksaw, etc.)
- ▶ All of the components must be dismantled and scrapped after having reduced them to small pieces so that none of them can be reasonably reused.
- ▶ When the jib crane is scrapped, its parts must be recycled taking into account their various natures (metals, oil and lubricants, plastic, rubber, etc.) possibly hiring specialised companies authorised for this purpose and complying with the laws regarding the disposal of solid industrial waste.



Do not attempt to reuse the parts or components of the jib crane that apparently may seem still intact once that they, following check and tests and/or replacements conducted by specialised personnel or the manufacturer, have been declared no longer suitable.

7. SPARE PARTS



- ▶ The jib cranes have been designed so they do not normally need spare parts due to **FAULTS OR BREAKAGE**, if they are used correctly and following adequate maintenance as described in this manual.
- ▶ If necessary, consult the "Jib crane components and spare parts" manual.
- ▶ Parts or components subject to normal wear and tear following use can be obtained from the manufacturer for a minimum period of 10 years.



- ▶ Do not hesitate to replace the part and/or component in question, if it is not able to offer sufficient guarantees on its safety and/or functional reliability.
- ▶ Do not ever make temporary or makeshift repairs!

When it is necessary to replace faulty parts, it is mandatory to only use original spare parts, by contacting the manufacturer directly.



DONATI SOLLEVAMENTI S.r.l.

Via Quasimodo, 17 - 20025 Legnano (MI)
Tel. +39 0331 14811 - Fax +39 0331 1481880
E-mail: dvo.info@donaticranes.com
www.donaticranes.com



The use of non-original spare parts, in addition to cancelling the warranty, may compromise the correct operation of the jib crane and/or its components.

GBP-GBA VERSION S "CHANNEL" PROFILED BOOM

CAPACITY (kg)	OUTREACH (Mt)	(A) COLUMN								TYPE	CODE	
		TYPE	HEIGHT (MT)									
			3	3,5	4	4,5	5	5,5	6			
63	4	R	GBA1R0300	GBA1R0350	GBA1R0400	GBA1R0450	GBA1R0500	/	/	KBK1	GBA1R1K40	
	5										GBA1R1K50	
	6	T	/	GBA1T0350	GBA1T0400	GBA1T0450	GBA1T0500	GBA1T0550	/	KBK2	GBA1T1K60	
	7		/								GBA1T1K70	
125	2	R	GBA1R0300	GBA1R0350	GBA1R0400	GBA1R0450	GBA1R0500	/	/	KBK1	GBA1R3K20	
	3										GBA1R0K30	
	4	S	GBA1S0300	GBA1S0350	GBA1S0400	GBA1S0450	GBA1S0500	/	/	KBK1	GBA1S3K40	
	5					GBA1S0500					GBA1S3K50	
	6	T	/	GBA1T0350	GBA1T0400	GBA1T0450	GBA1T0500	GBA1T0550	/	KBK2	GBA1T3K60	
	7										GBA1T3K70	
250	2	R	GBA1R0300	GBA1R0350	GBA1R0400	GBA1R0450	GBA1R0500	/	/	KBK1	GBA1R4K20	
	3	S	GBA1S0300	GBA1S0350	GBA1S0400	GBA1S0450						
	4	T	/	GBA1T0350	GBA1T0400	GBA1T0450	GBA1T0500	GBA1T0550	/	KBK1	GBA1T4K40	
	5										GBA1T4K50	
	6	U	/	GBA1U0350	GBA1U0400	GBA1U0450	GBA1U0500	GBA1U0550	/	KBK2	GBA1U4K60	
7									GBA1U4K70			
500	2	T	/	GBA1T0350	GBA1T0400	GBA1T0450	GBA1T0500	GBA1T0550	/	KBK2	GBA1T5K20	
	3										GBA1T5K30	
	4	U	/	GBA1U0350	GBA1U0400	GBA1U0450	GBA1U0500	GBA1U0550	/	KBK2	GBA1U5K40	
	5										GBA1U5K50	
	6	V	/	/	GBA1V0400	GBA1V0450	GBA1V0500	GBA1V0550	GBA1V0600	KBK2	GBA1V5K60	
7									GBA1V5K70			
800	7	Z	/	/	GBA1Z0400	GBA1Z0450	GBA1Z0500	GBA1Z0550	GBA1Z0600	KBK2	GBA1Z6K70	
1000	2	U	/	GBA1U0350	GBA1U0400	GBA1U0450	GBA1U0500	GBA1U0550	/	KBK2	GBA1U7K20	
	3										GBA1U7K30	
	4	V	/	/	GBA1V0400	GBA1V0450	GBA1V0500	GBA1V0550	GBA1V0600	KBK2	GBA1V7K40	
	5										GBA1V7K50	
	6	Z	/	/	GBA1Z0400	GBA1Z0450	GBA1Z0500	GBA1Z0550	GBA1Z0600	KBK2	GBA1Z7K60	

*E31012002 Switch | **E240M25L0 Cable gland

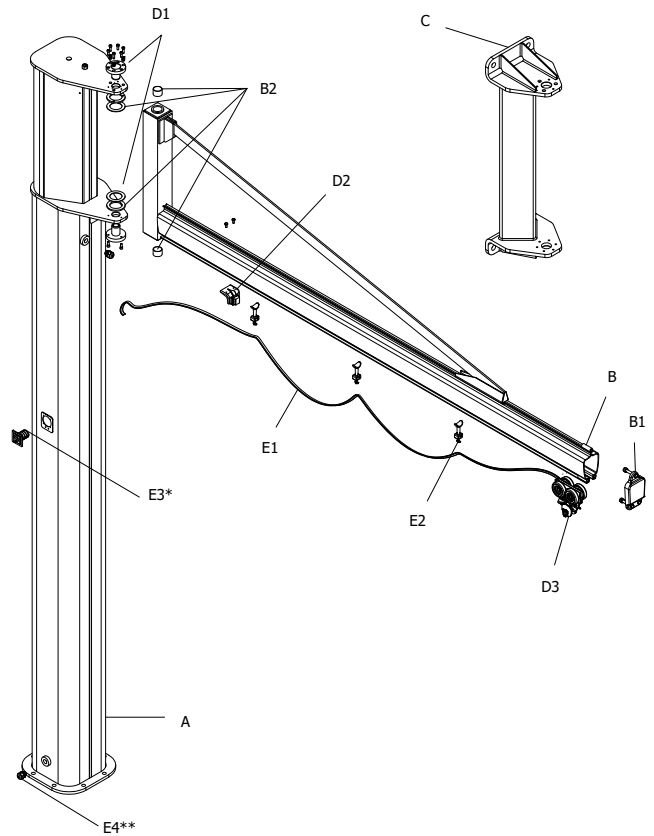

B) BOOM		(C) BRACKET		(D) COMPLETION KIT				(E) POWER SUPPLY for column-mounted cranes without main on/off switch see wall crane system					
B1	B2	TYPE	CODE	CODE	D1	D2	D3	COLUMN	WALL	E1	Mt	E2	Qty.
GBK010160	GBA1AS010	A/B	GBK010AB0	GBA1R0000	GBA1R0240	GBK010170	CCK100000	GBA1A0C40	GBP1A0C40	E0800415P	6	E58000001	3
								GBA1A0C50	GBP1A0C50				4
GBK020160	GBA1CS010	C/D	GBP020CD0	GBA2T0000	GBA1T0240	GBK020170	CCK200000	GBA1A0C60	GBP1A0C60	E0800415P	8	E58000001	5
								GBA1A0C70	GBP1A0C70				9
GBK010160	GBA1AS010	A/B	GBK010AB0	GBA1R0000	GBA1R0240	GBK010170	CCK100000	GBA1A0C20	GBP1A0C20	E0800415P	4	E58000001	2
GBA1A0C30								GBP1A0C30	5				
GBA1A0C40								GBP1A0C40	6				
GBA1A0C50								GBP1A0C50	7				
GBK010160	GBA1CS010	C/D	GBP020CD0	GBA2T0000	GBA1T0240	GBK020170	CCK200000	GBA1A0C60	GBP1A0C60	E0800415P	8	E58000001	5
GBA1A0C70								GBP1A0C70	9				
GBK020160	GBA1CS010	C/D	GBP020CD0	GBA2T0000	GBA1T0240	GBK020170	CCK200000	GBA1A0C20	GBP1A0C20	E0800415P	4	E58000001	2
GBA1A0C30								GBP1A0C30	5				
GBK010160	GBA1AS010	A/B	GBK010AB0	GBA1R0000	GBA1R0240	GBK010170	CCK100000	GBA1A0C20	GBP1A0C20	E0800415P	4	E58000001	2
GBA1A0C30								GBP1A0C30	5				
GBK010160	GBA1CS010	C/D	GBP020CD0	GBA1T0000	GBA1T0240	GBK010170	CCK100000	GBA1A0C40	GBP1A0C40	E0800415P	6	E58000001	3
GBA1A0C50								GBP1A0C50	7				
GBK020160	GBA1CS010	C/D	GBP020CD0	GBA2T0000	GBA1T0240	GBK020170	CCK200000	GBA1A0C60	GBP1A0C60	E0800415P	8	E58000001	5
GBA1A0C70								GBP1A0C70	9				
GBK020160	GBA1CS010	C/D	GBP020CD0	GBA2T0000	GBA1T0240	GBK020170	CCK200000	GBA1A0C20	GBP1A0C20	E0800415P	4	E58000001	2
								GBA1A0C30	GBP1A0C30				5
GBK020160	GBA1ES010	E/F	GBP030EF0	GBA2V0000	GBA1V0240	GBK020170	CCK200000	GBA1A0C40	GBP1A0C40	E0800415P	6	E58000001	3
								GBA1A0C50	GBP1A0C50				7
GBK020160	GBA1ES010	E/F	GBP030EF0	GBA2V0000	GBA1V0240	GBK020170	CCK200000	GBA1A0C60	GBP1A0C60	E0800415P	8	E58000001	5
								GBA1A0C70	GBP1A0C70				9
GBK020160	GBA1ES010	E/F	GBP030EF0	GBA2Z0000	GBA1V0240	GBK020170	CCK2D00P0	GBA1A0C70	GBP1A0C70	E0800415P	9	E58000001	6
GBK020160	GBA1CS010	C/D	GBP020CD0	GBA2U0000	GBA1T0240	GBK020170	CCK2D00P0	GBA1A0C20	GBP1A0C20	E0800415P	4	E58000001	2
								GBA1A0C30	GBP1A0C30				5
GBK020160	GBA1ES010	E/F	GBP030EF0	GBA2Z0000	GBA1V0240	GBK020170	CCK2D00P0	GBA1A0C40	GBP1A0C40	E0800415P	6	E58000001	3
								GBA1A0C50	GBP1A0C50				7
GBK020160	GBA1ES010	E/F	GBP030EF0	GBA2Z0000	GBA1V0240	GBK020170	CCK2D00P0	GBA1A0C60	GBP1A0C60	E0800415P	8	E58000001	5
								GBA1A0C70	GBP1A0C70				9

GBP-GBA VERSION T-BOOM IN "CANTILEVER" BEAM

CAPACITY (kg)	OUTREACH (Mt)	(A) COLUMN								TYPE	
		TYPE	HEIGHT (MT)								
			3	3,5	4	4,5	5	5,5	6		
63	4	R	GBA1R0300	GBA1R0350	GBA1R0400	GBA1R0450	GBA1R0500	/	/	IPE 160	
	5										
125	2	R	GBA1R0300	GBA1R0350	GBA1R0400	GBA1R0450	GBA1R0500	/	/	IPE 160	
	3										
	4	S	GBA1S0300	GBA1S0350	GBA1S0400	GBA1S0450	GBA1S0500	/	/	IPE 200	
	5										
250	2	S	GBA1S0300	GBA1S0350	GBA1S0400	GBA1S0450	GBA1S0500	/	/	IPE 200	
	3										
	4	T	/	GBA1T0350	GBA1T0400	GBA1T0450	GBA1T0500	GBA1T0550	/	IPE 240	
	5										
	6	V	/	/	GBA1V0400	GBA1V0450	GBA1V0500	GBA1V0550	GBA1V0600	IPE 300	
7											
500	2	T	/	/	GBA1T0350	GBA1T0400	GBA1T0450	GBA1T0500	GBA1T0550	/	IPE 240
	3										
	4	U	/	/	GBA1U0350	GBA1U0400	GBA1U0450	GBA1U0500	GBA1U0550	/	IPE 300
	5										
	6	V	/	/	/	GBA1V0400	GBA1V0450	GBA1V0500	GBA1V0550	GBA1V0600	IPE 360
	6										
	6	Z1	/	/	/	GBA1Z0400	GBA1Z0450	GBA1Z0500	GBA1Z0550	GBA1Z0600	IPE 360
	7										
7	V	/	/	/	/	/	/	/	/	IPE 400	
7											
7	Z1	/	/	/	/	GBA1Z0400	GBA1Z0450	GBA1Z0500	GBA1Z0550	GBA1Z0600	IPE 400
7											
1000	2	U	/	/	GBA1U0350	GBA1U0400	GBA1U0450	GBA1U0500	GBA1U0550	/	IPE 300
	3										
	4	V	/	/	/	GBA1V0400	GBA1V0450	GBA1V0500	GBA1V0550	GBA1V0600	IPE 360
	5										
	6	Z1	/	/	/	/	/	/	/	/	IPE 400
7											
7	/	/	/	/	/	/	/	/	/	IPE 450	
7											
1600	6	/	/	/	/	/	/	/	/	/	IPE 450
2000	2	V	/	/	/	GBA1V0400	GBA1V0450	GBA1V0500	GBA1V0550	GBA1V0600	IPE 360
	3										
	4	Z2	/	/	/	GBA1Z0400	GBA1Z0450	GBA1Z0500	GBA1Z0550	GBA1Z0600	IPE 400
	5										
5	/	/	/	/	/	/	/	/	/	IPE 450	
5											

*E31012002 Switch | **E240M25L0 Cable gland

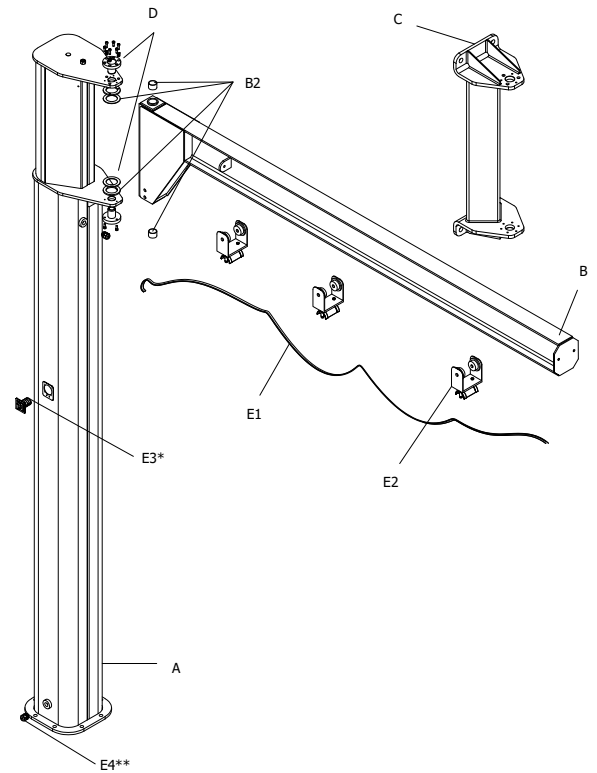

(B) BOOM		(C) BRACKET		(D) COMPLETION KIT	(E) POWER SUPPLY for column-mounted cranes without main on/off switch see wall crane system					
CODE	B2	TIPO	CODE	CODE	COLUMN	WALL	E1	Mt	E2	Qty.
GBA2A0140	GBA1AS010	AB	GBK010AB0	GBA1R0240	GBA1B0T40	GBP1B0T40	E0800415P	9	E46000015	3
GBA2A0150					GBA1B0T50	GBP1B0T50		10		4
GBA2A0160	GBA1AS010	AB	GBK010AB0	GBA1R0240	GBA1B0T20	GBP1B0T20	E0800415P	7	E46000015	2
GBA2A0170					GBA1B0T30	GBP1B0T30		8		3
GBA2B0190					GBA1B0T40	GBP1B0T40		9		3
GBA2B0200					GBA1B0T50	GBP1B0T50		10		4
GBA2B0210	GBA1AS010	AB	GBK010AB0	GBA1R0240	GBA1B0T20	GBP1B0T20	E0800415P	7	E46000015	2
GBA2B0220					GBA1B0T30	GBP1B0T30		8		3
GBA2C0240	GBA1CS010	CD	GBP020C00	GBA1T0240	GBA1B0T40	GBP1B0T40	E0800415P	9	E46000015	3
GBA2C0250					GBA1B0T50	GBP1B0T50		10		4
GBA2E0330	GBA1ES010	EF	GBP030EFO	GBA1V0240	GBA1D0T60	GBP1D0T60	E0800415P	11	E46000018	5
GBA2E0380					GBA1F0T75	GBP1F0T75		12		6
GBA2C0260					GBA1B0T20	GBP1B0T20		7		2
GBA2C0270					GBA1B0T30	GBP1B0T30		8		3
GBA2D0290	GBA1CS010	CD	GBP020C00	GBA1T0240	GBA1B0T40	GBP1B0T40	E0800415P	9	E46000015	3
GBA2D0300					GBA1B0T50	GBP1B0T50		10		4
GBA2F0310	GBA1ES010	EF	GBP030EFO	GBA1V0240	GBA1F0T65	GBP1F0T65	E0800415P	11	E46000018	5
GBA2F0310		/	/		GBA1F0T65	/		12		5
GBA2F0340		EF	GBP030EFO		GBA1F0T75	GBP1F0T75		12		6
GBA2F0340		/	/		GBA1F0T75	/		12		6
GBA2D0310	GBA1CS010	CD	GBP020C00	GBA1T0240	GBA1B0T20	GBP1B0T20	E0800415P	7	E46000015	2
GBA2D0320					GBA1B0T30	GBP1B0T30		8		3
GBA2E0340	GBA1ES010	EF	GBP030EFO	GBA1V0240	GBA1F0T45	GBP1F0T45	E0800415P	9	E46000018	3
GBA2E0350					GBA1F0T55	GBP1F0T55		10		4
GBA2F0330					GBA1F0T65	GBP1F0T65		11		5
GBA2F0370					/	GBP1F0T75		12		6
GBA2F0360	GBA1ES010	EF	GBP030EFO	GBA1V0240	/	GBP1F0T65	E0800415P	11	E46000018	5
GBA2E0360	GBA1ES010	EF	GBP030EFO	GBA1V0240	GBA1E0T25	GBP1E0T25	E0800415P	7	E46000018	2
GBA2E0370					GBA1E0T35	GBP1E0T35		8		3
GBA2F0320					GBA1F0T45	GBP1F0T45		9		3
GBA2F0350					/	GBP1F0T55		10		4

GBP-GBA VERSION H-BOOM IN PROFILED BEAM WITH "TIE ROD"

CAPACITY (kg)	OUTREACH (Mt)	(A) COLUMN								TYPE	
		TYPE	HEIGHT (MT)						TYPE		
			3	3,5	4	4,5	5	5,5			6
125	6	T	/	GBA1T0350	GBA1T0400	GBA1T0450	GBA1T0500	GBA1T0550	/	IPE 160	
	7			GBA1U0350	GBA1U0400	GBA1U0450	GBA1U0500	GBA1U0550		IPE 200	
	8	U	GBA1U0350	GBA1U0400	GBA1U0450	GBA1U0500	GBA1U0550	IPE 200			
250	4	T	/	GBA1T0350	GBA1T0400	GBA1T0450	GBA1T0500	GBA1T0550	/	IPE 160	
	5			U	GBA1U0350	GBA1U0400	GBA1U0450	GBA1U0500		GBA1U0550	IPE 200
	6										
	7										
	8	V		/	/	GBA1V0400	GBA1V0450	GBA1V0500	GBA1V0550	GBA1V0600	
500	4	U	/	GBA1U0350	GBA1U0400	GBA1U0450	GBA1U0500	GBA1U0550	/	IPE 200	
	5										
	6	V		/	/	GBA1V0400	GBA1V0450	GBA1V0500	GBA1V0550	GBA1V0600	
	7										
	8			Z1	/	/	GBA1Z0400	GBA1Z0450	GBA1Z0500	GBA1Z0550	GBA1Z0600
1000	4	V	/	/	GBA1V0400	GBA1V0450	GBA1V0500	GBA1V0550	GBA1V0600	IPE 200	
	5										
	6	Z1		/	/	GBA1Z0400	GBA1Z0450	GBA1Z0500	GBA1Z0550	GBA1Z0600	IPE 240
	7										
	8			Z2	/	/					
1600	6	Z2	/	/	/	GBA1Z0450	GBA1Z0500	GBA1Z0550	GBA1Z0600	IPE 240	
2000	4	Z2	/	/	GBA1Z0400	GBA1Z0450	GBA1Z0500	GBA1Z0550	GBA1Z0600	IPE 240	
	5										

*E31012002 Switch | **E240M25L0 Cable gland

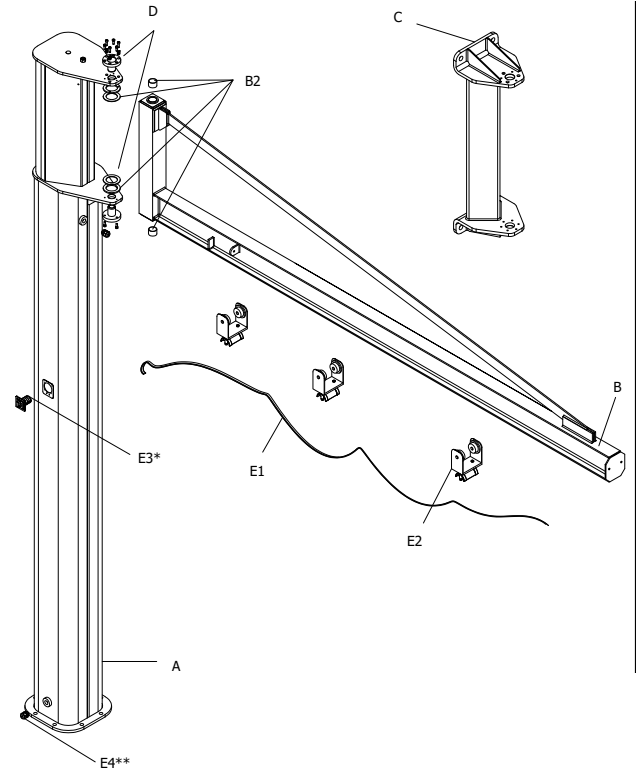

(B) BOOM		(C) BRACKET		(D) COMPLETION KIT	(E) POWER SUPPLY for column-mounted cranes without main on/off switch see wall crane system					
CODE	B2	TIPO	CODE	CODE	COLUMN	WALL	E1	Mt	E2	Qty.
GBA1C0920		CD			GBA1D0T60	GBP1D0T60		11		5
GBA1C0930	GBA1CS010	CD	GBP020CDO	GBA1T0240	GBA1D0T70	GBP1D0T70	E0800415P	12	E46000015	6
GBA1D0960		CD			GBA1D0T80	GBP1D0T80		13		7
GBA1C0940	GBA1CS010	CD	GBP020CDO	GBA1T0240	GBA1B0T40	GBP1B0T40	E0800415P	9	E46000015	3
GBA1C0950		CD			GBA1B0T50	GBP1B0T50		10		3
GBA1D0970		CD			GBA1D0T60	GBP1D0T60		11		5
GBA1D0980		CD			GBA1D0T70	GBP1D0T70		12		6
GBA2E0010	GBA1ES010	EF	GBP030EFO	GBA1V0240	GBA1D0T80	GBP1D0T80		13		7
GBA1D0990	GBA1CS010	CD	GBP020CDO	GBA1T0240	GBA1B0T40	GBP1B0T40		9		3
GBA2D0000		CD			GBA1B0T50	GBP1B0T50		10		4
GBA2E0020		EF			GBA1D0T60	GBP1D0T60	E0800415P	11	E46000015	5
GBA2E0030	GBA1ES010	EF	GBP030EFO	GBA1V0240	GBA1D0T70	GBP1D0T70		12		6
GBA2F0070		EF			GBA1D0T80	GBP1D0T80		13		7
GBA2E0040	GBA1ES010	EF	GBP030EFO	GBA1V0240	GBA1B0T40	GBP1B0T40	E0800415P	9	E46000015	3
GBA2E0050		EF			GBA1B0T50	GBP1B0T50		10		4
GBA2F0080		EF			GBA1D0T60	GBP1D0T60		11		5
GBA2F0090		EF			GBA1D0T60	GBP1D0T70		12		6
GBA2F0076		EF			GBA1D0T80	GBP1D0T80		13		7
GBA2F0085	GBA1ES010	EF	GBP030EFO	GBA1V0240	GBA1D0T60	GBP1D0T60	E0800415P	12	E46000015	6
GBA2F0100	GBA1ES010	EF	GBP030EFO	GBA1V0240	GBA1B0T40	GBP1B0T40	E0800415P	9	E46000015	3
GBA2F0110		EF			GBA1B0T50	GBP1B0T50		10		4

GBA SERIES JIB CRANE WITH DOUBLE BOOM, "C" TYPE CHANNEL VERSION, "CHANNEL" PROFILED BOOM

CAPACITY (kg)	OUTREACH (Mt)	(A) COLUMN								TYPE
		TYPE	HEIGHT (MT)						TYPE	
			3	3,5	4	4,5	5	5,5		
63 + 63	2	R	GBA2R0300	GBA2R0350	GBA2R0400	GBA2R0450	GBA2R0500	/	/	P
	3									
	4	S	GBA2S0300	GBA2S0350	GBA2S0400	GBA2S0450	GBA2S0500	/	/	P
	5									
	6	T	/	GBA2T0350	GBA2T0400	GBA2T0450	GBA2T0500	GBA2T0550	/	P
7										
125 + 125	2	S	GBA2S0300	GBA2R0350	GBA2S0400	GBA2S0450	GBA2S0500	/	/	P
	3									
	4	T	/	GBA2T0350	GBA2T0400	GBA2T0450	GBA2T0500	GBA2T0550	/	P
	5									
	6	U	/	GBA2U0350	GBA2U0400	GBA2U0450	GBA2U0500	GBA2U0550	/	P
7										
250 + 250	2	T	/	GBA2T0350	GBA2T0400	GBA2T0450	GBA2T0500	GBA2T0550	/	P
	3									
	4	U	/	GBA2U0350	GBA2U0400	GBA2U0450	GBA2U0500	GBA2U0550	/	P
	5									
	6	V	/	/	GBA2V0400	GBA2V0450	GBA2V0500	GBA2V0550	GBA2V0600	G
7										
500 + 500	2	U	/	GBA2U0350	GBA2U0400	GBA2U0450	GBA2U0500	GBA2U0550	/	P
	3									
	4	V	/	/	GBA2V0400	GBA2V0450	GBA2V0500	GBA2V0550	GBA2V0600	G
	5									
	6	Z	/	/	GBA2Z0400	GBA2Z0450	GBA2Z0500	GBA2Z0550	GBA2Z0600	G
7										
1000 +1000	2	V	/	/	GBA2V0400	GBA2V0450	GBA2V0500	GBA2V0550	GBA2V0600	G
	3									
	4	Z	/	/	GBA2Z0400	GBA2Z0450	GBA2Z0500	GBA2Z0550	GBA2Z0600	G
	5									

*E31012002 Switch | **E240M25L0 Cable gland

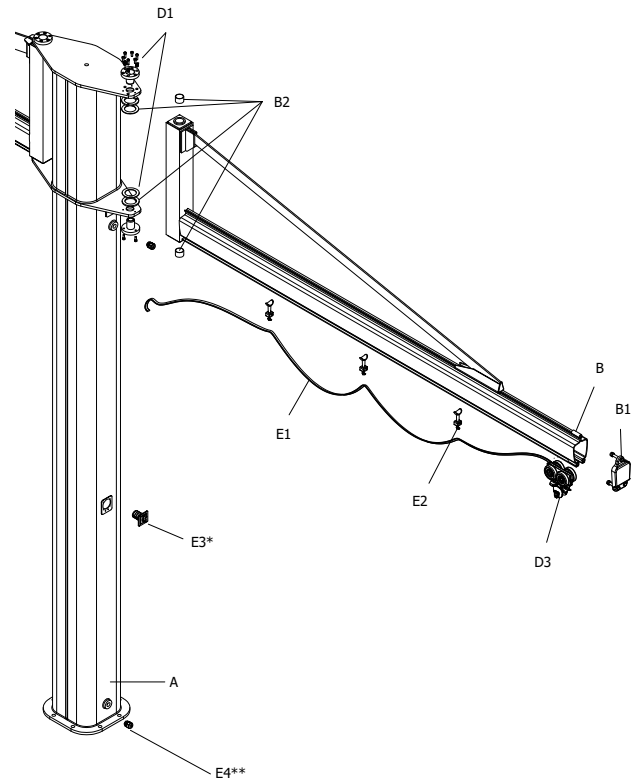

(B) BOOM			(D) COMPLETION KIT		(E) POWER SUPPLY				
CODE	B1	B2	CODE	D3	COLUMN	E1	Mt	E2	Qty.
GBA1R0620	JSCA0LP00	GBA1AS010	GBA1R0240	OCCP00000	GBA1A0C20	E0800415P	4	E58000001	2
GBA1R0630					GBA1A0C30		5		3
GBA1A0600					GBA1A0C40		6		6
GBA1A0610					GBA1A0C50		7		4
GBA1T0660					GBA1A0C60		8		5
GBA1T0750		GBA1CS010	GBA1T0240		GBA1A0C70	9		6	
GBA1A0620	JSCA0LP00	GBA1AS010	GBA1R0240	OCCP00000	GBA1A0C20	E0800415P	4	E58000001	2
GBA1A0630					GBA1A0C30		5		3
GBA1T0700					GBA1A0C40		6		3
GBA1T0710					GBA1A0C50		7		4
GBA1C0660					GBA1A0C60		8		5
GBA1C0750		GBA1CS010	GBA1T0240		GBA1A0C70	9		6	
GBA1T0730	JSCA0LP00	GBA1CS010	GBA1T0240	OCCP00000	GBA1A0C20	E0800415P	4	E58000001	2
GBA1T0740					GBA1A0C30		5		3
GBA1C0700					GBA1A0C40		6		3
GBA1C0710					GBA1A0C50		7		4
GBA1V0830					GBA1A0C60		8		5
GBA1V0840	JSCA0LG00	GBA1ES010	GBA1V0240	OCCG00000	GBA1A0C70	9		6	
GBA1C0730	JSCA0LP00	GBA1CS010	GBA1T0240	CCPD00000	GBA1A0C20	E0800415P	4	E58000001	2
GBA1C0740					GBA1A0C30		5		3
GBA1V0870	JSCA0LG00	GBA1ES010	GBA1V0240	OCCG00000	GBA1A0C40	E0800415P	6	E58000001	3
GBA1V0880					GBA1A0C50		7		4
GBA1E0830					GBA1A0C60		8		5
GBA1E0840					GBA1A0C70		9		6
GBA1V0860							GBA1A0C20		
GBA1E0850	JSCA0LG00	GBA1ES010	GBA1V0240	CCGD00000	GBA1A0C30	E0800415P	5	E58000001	3
GBA1E0870					GBA1A0C40		6		3
GBA1E0880					GBA1A0C50		7		4

GBA SERIES JIB CRANE – T-BOOM VERSION DOUBLE BOOM, IN "CANTILEVER" PROFILED BEAM

CAPACITY (kg)	OUTREACH (Mt)	(A) COLUMN								
		TYPE	HEIGHT (MT)						5,5	6
			3	3,5	4	4,5	5			
63 + 63	2	R	GBA2R0300	GBA2R0350	GBA2R0400	GBA2R0450	GBA2R0500	/	/	
	3									
	4	S	GBA2S0300	GBA2S0350	GBA2S0400	GBA2S0450	GBA2S0500	/	/	
	5									
125 + 125	2	S	GBA2S0300	GBA2S0350	GBA2S0400	GBA2S0450	GBA2S0500	/	/	
	3									
	4	T	/	GBA2T0350	GBA2T0400	GBA2T0450	GBA2T0500	GBA2T0550	/	
	5									
	6	V	/	/	GBA2V0400	GBA2V0450	GBA2V0500	GBA2V0550	GBA2V0600	
7										
250 + 250	2	T	/	GBA2T0350	GBA2T0400	GBA2T0450	GBA2T0500	GBA2T0550	/	
	3									
	4	U	/	GBA2U0350	GBA2U0400	GBA2U0450	GBA2U0500	GBA2U0550	/	
	5									
	6	V	/	/	GBA2V0400	GBA2V0450	GBA2V0500	GBA2V0550	GBA2V0600	
	6	Z	/	/	GBA2Z0400	GBA2Z0450	GBA2Z0500	GBA2Z0550	GBA2Z0600	
	7	V	/	/	GBA2V0400	GBA2V0450	GBA2V0500	GBA2V0550	GBA2V0600	
7	Z	/	/	GBA2Z0400	GBA2Z0450	GBA2Z0500	GBA2Z0550	GBA2Z0600		
500 + 500	2	U	/	GBA2U0350	GBA2U0400	GBA2U0450	GBA2U0500	GBA2U0550	/	
	3									
	4	V	/	/	GBA2V0400	GBA2V0450	GBA2V0500	GBA2V0550	GBA2V0600	
	5									
6	Z	/	/	GBA2Z0400	GBA2Z0450	GBA2Z0500	GBA2Z0550	GBA2Z0600		
1000+1000	2	V	/	/	GBA2V0400	GBA2V0450	GBA2V0500	GBA2V0550	GBA2V0600	
	3									
	4	Z	/	/	GBA2Z0400	GBA2Z0450	GBA2Z0500	GBA2Z0550	GBA2Z0600	

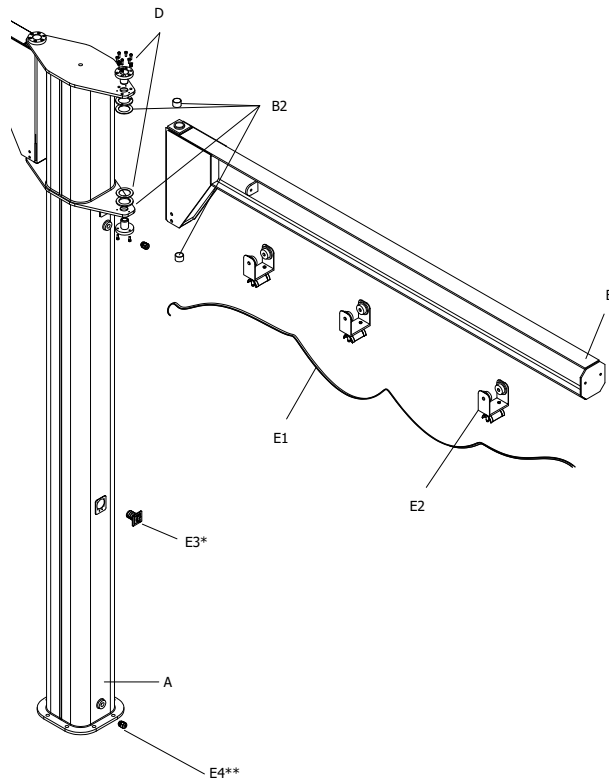

(B) BOOM		(D) COMPLETION KIT		(E) POWER SUPPLY				
TYPE	CODE	B2	CODE	COLUMN	E1	Mt	E2	Qty.
IPE 160	GBA2R0160	GBA1AS010	GBA1R0240	GBA1B0T20	E0800415P	7	E46000015	2
	GBA2R0170			GBA1B0T30		8		3
	GBA2A0140			GBA1B0T40		9		3
	GBA2A0150			GBA1B0T50		10		4
IPE 160	GBA2A0160	GBA1AS010	GBA1R0240	GBA1B0T20	E0800415P	7	E46000015	2
	GBA2A0170			GBA1B0T30		8		3
IPE 240	GBA2T0240	GBA1CS010	GBA1T0240	GBA1B0T40	E0800415P	9	E46000015	3
	GBA2T0250			GBA1B0T50		10		4
IPE 300	GBA2V0330	GBA1ES010	GBA1V0240	GBA1D0T60	E0800415P	11	E46000018	5
	GBA2V0380			GBA1F0T75		12		6
IPE 240	GBA2T0260	GBA1CS010	GBA1T0240	GBA1B0T20	E0800415P	7	E46000015	2
	GBA2T0270			GBA1B0T30		8		3
	GBA2C0240			GBA1B0T40		9		4
	GBA2C0250			GBA1B0T50		10		4
IPE 300	GBA2E0330	GBA1ES010	GBA1V0240	GBA1D0T60	E0800415P	11	E46000018	5
IPE 360	GBA2E0380			GBA1F0T75		12		6
IPE 240	GBA2C0260	GBA1CS010	GBA1T0240	GBA1B0T20	E0800415P	7	E46000015	2
	GBA2C0270			GBA1B0T30		8		
IPE 360	GBA2V0340	GBA1ES010	GBA1V0240	GBA1F0T45	E0800415P	9	E46000018	3
	GBA2V0350			GBA1F0T55		10		4
	GBA2F0310			GBA1F0T65		11		5
IPE 360	GBA2V0360	GBA1ES010	GBA1V0240	GBA1E0T25	E0800415P	7	E46000018	2
	GBA2V0370			GBA1E0T35		8		3
	GBA2E0340			GBA1F0T45		9		3

MBE-CBE SERIES JIB CRANE – MOTORISED H-BOOM VERSION, IN PROFILED BEAM WITH “TIE ROD”

CAPACITY (kg)	OUTREACH (Mt)	(A) COLUMN						
		TYPE	HEIGHT (MT)					
			3,5	4	4,5	5	5,5	6
125 + 125	4	T	GBA2T0350	GBA2T0400	GBA2T0450	GBA2T0500	GBA2T0550	/
	5							
	6	U	GBA2U0350	GBA2U0400	GBA2U0450	GBA2U0500	GBA2U0550	/
	7							
	8		V	/	GBA2V0400	GBA2V0450	GBA2V0500	GBA2V0550
250 + 250	4	U	GBA2U0350	GBA2U0400	GBA2U0450	GBA2U0500	GBA2U0550	/
	5							
	6	V	/	GBA2V0400	GBA2V0450	GBA2V0500	GBA2V0550	GBA2V0600
	7							
	8		Z	/	GBA2Z0400	GBA2Z0450	GBA2Z0500	GBA2Z0550
500 + 500	4	V	/	GBA2V0400	GBA2V0450	GBA2V0500	GBA2V0550	GBA2V0600
	5							
	6	Z	/	GBA2Z0400	GBA2Z0450	GBA2Z0500	GBA2Z0550	GBA2Z0600
	7							
	8							
800 + 800	6	Z	/	GBA2Z0400	GBA2Z0450	GBA2Z0500	GBA2Z0550	GBA2Z0600
1000 + 1000	3	Z	/	GBA2Z0400	GBA2Z0450	GBA2Z0500	GBA2Z0550	GBA2Z0600
	4							

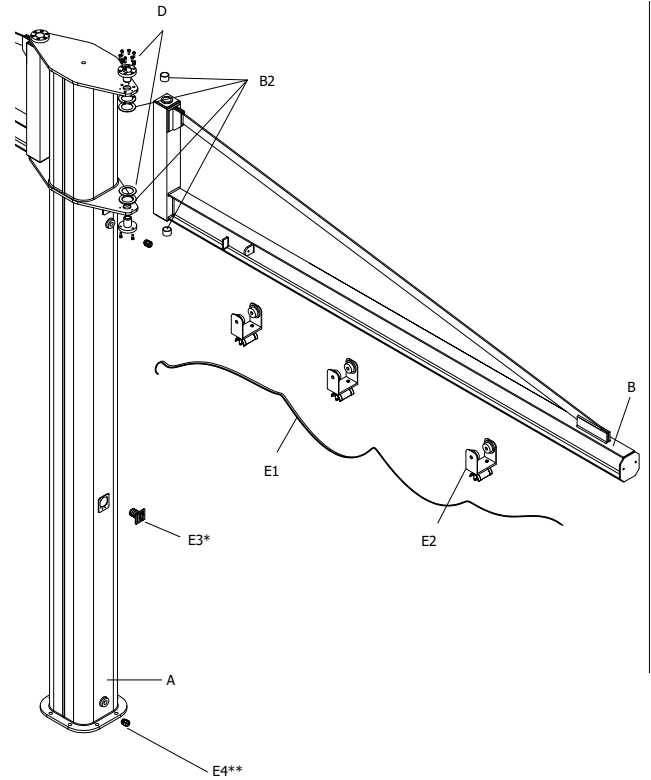

(B) BOOM			(D) COMPLETION KIT	(E) POWER SUPPLY				
TYPE	CODE	B2	CODE	COLUMN	E1	Mt	E2	Qty.
IPE 160	GBA1T0940	GBA1CS010	GBA1T0240	GBA1B0T40	E0800415P	9	E46000015	3
	GBA1T0950			GBA1B0T50		10		4
IPE 160	GBA1C0920			GBA1D0T60		11		5
	GBA1C0930			GBA1D0T70		12		6
IPE 200	GBA2E0010	GBA1ES010	GBA1V0240	GBA1D0T80		13		7
IPE 160	GBA1C0940	GBA1CS010	GBA1T0240	GBA1B0T40		9		3
	GBA1C0950			GBA1B0T50	10	4		
	GBA2V0020			GBA1D0T60	E0800415P	11	E46000015	5
IPE 200	GBA2V0030	GBA1ES010	GBA1V0240	GBA1D0T70		12		6
	GBA2E0010			GBA1D0T80		13		7
IPE 200	GBA2V0040	GBA1ES010	GBA1V0240	GBA1B0T40	E0800415P	9	E46000015	3
	GBA2V0050			GBA1B0T50		10		4
IPE 200	GBA2E0020			GBA1D0T60		11		5
	GBA2E0030			GBA1D0T70		12		6
IPE 240	GBA2F0070			GBA1D0T80		13		7
IPE 240	GBA2Z0085	GBA1ES010	GBA1V0240	GBA1D0T60	E0800415P	11	E46000015	5
IPE 200	GBA2E0040	GBA1ES010	GBA1V0240	GBA1B0T40	E0800415P	9	E46000015	3
	GBA2E0050			GBA1B0T50		10		4

MBE-CBE SERIES JIB CRANE – MOTORISED T-BOOM VERSION, IN “CANTILEVER” PROFILED BEAM

CAPACITY (kg)	OUTREACH (Mt)	(A) COLUMN							(B) BOOM		
		TYPE	HEIGHT (MT)						TYPE	CODE	B2
			3,5	4	4,5	5	5,5	6			
250	6	U	CBE1U0350	CBE1U0400	CBE1U0450	CBE1U0500	CBE1U0550	/	IPE 200	CBE1D0160	GBA1CS010
	7								HEA 160	CBE1D0170	
	8	V	/	CBE1V0400	CBE1V0450	CBE1V0500	CBE1V0550	CBE1V0600	HEA 160	CBE1E0180	GBA1ES010
500	4	U	CBE1U0350	CBE1U0400	CBE1U0450	CBE1U0500	CBE1U0550	/	IPE 200	CBE1D0140	GBA1CS010
	5									CBE1D0150	
	6	V	/	CBE1V0400	CBE1V0450	CBE1V0500	CBE1V0550	CBE1V0600	IPE 200	CBE1E0160	GBA1ES010
	7								HEA 160	CBE1E0170	
	8									Z1	
1000	4	V	/	CBE1V0400	CBE1V0450	CBE1V0500	CBE1V0550	CBE1V0600	IPE 200	CBE1E0140	
	5									CBE1E0150	
	6	Z1	/	CBE1Z0400	CBE1Z0450	CBE1Z0500	CBE1Z0550	CBE1Z0600	IPE 240	CBE1F0160	GBA1ES010
	7								HEA 160	CBE1F0170	
	8								Z2	/	
1600	6	Z2	/	CBE1Z0400	CBE1Z0450	CBE1Z0500	CBE1Z0550	CBE1Z0600	HEA 160	CBE1F0190	GBA1ES010
2000	4	Z2	/	CBE1Z0400	CBE1Z0450	CBE1Z0500	CBE1Z0550	CBE1Z0600	IPE 240	CBE1F0140	GBA1ES010
	5									CBE1F0150	

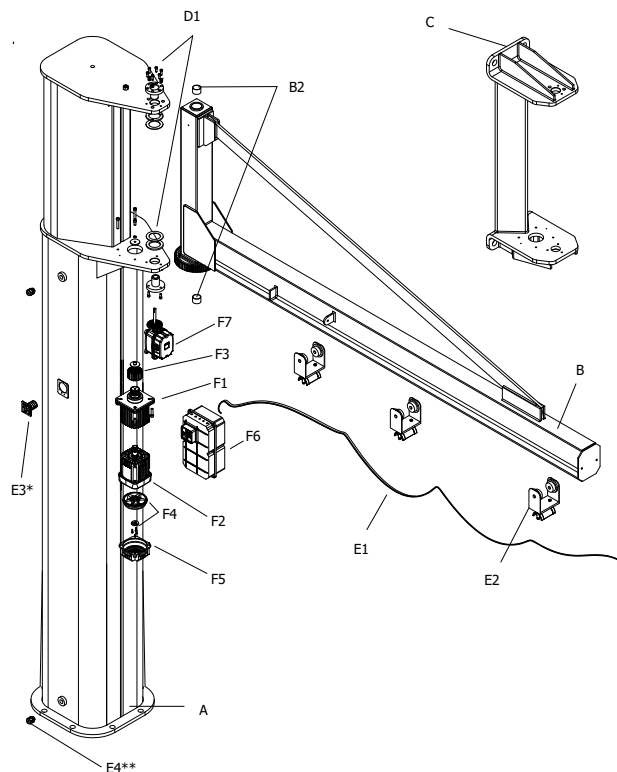

(C) BRACKET		(D) COMPLETION KIT	(E) POWER SUPPLY for column-mounted cranes without main on/off switch, see wall crane system						(F) MOTOR REDUCER UNIT CBE1F0020 (single phase) / CBE1F0050 (three phase)						
TYPE	CODE	CODE	COLUMN	WALL	E1	Mt	E2	Qty.	F1	F2	F3	F4	F5	F6	F7
C/D	MBE1D0030	CBE1D0210	CBE1D0T60	MBE1D0T60		9		4							
			CBE1D0T70	MBE1D0T70		10		5							
E/F	MBE1F0030	CBE1F0210	CBE1D0T80	MBE1D0T80		12		6							
C/D	MBE1D0030	CBE1D0210	CBE1D0T40	MBE1D0T40		6		3							
			CBE1D0T50	MBE1D0T50		8		4							
E/F	MBE1F0030	CBE1F0210	CBE1D0T60	MBE1D0T60		9		4							
			CBE1D0T70	MBE1D0T70		10		5							
			CBE1D0T80	MBE1D0T80		12		6							
E/F	MBE1F0030	CBE1F0210	CBE1D0T40	MBE1D0T40	E0801215P	6	E46000013	3	CBE1F0011	M30AT80002 (Three phase) M30DT80000 (Single phase)	CBE5F0070	M2001S020	M2001S010	CBE1E0030 (Three phase) CBE1F0030 (Single phase)	E6000GF4C
			CBE1D0T50	MBE1D0T50	8	4									
			CBE1D0T60	MBE1D0T60	9	4									
E/F	MBE1F0030	CBE1F0210	CBE1D0T70	MBE1D0T70		10		5							
			CBE1D0T80	MBE1D0T80		12		6							
			CBE1D0T60	MBE1D0T60		9		4							
E/F	MBE1F0030	CBE1F0210	CBE1D0T40	MBE1D0T40		6		3							
E/F	MBE1F0030	CBE1F0210	CBE1D0T50	MBE1D0T50		8		4							

MBE-CBE SERIES JIB CRANE – MOTORISED T-BOOM VERSION, IN “CANTILEVER” PROFILED BEAM

CAPACITY (kg)	OUTREACH (Mt)	(A) COLUMN							(B) BOOM		
		TYPE	HEIGHT (MT)						TYPE	CODE	B2
			3,5	4	4,5	5	5,5	6			
500	4	U	CBE1U0350	CBE1U0400	CBE1U0450	CBE1U0500	CBE1U0550	/	IPE 300	CBE1D0240	GBA1CS010
	5									CBE1D0250	
	6	V	/	CBE1V0400	CBE1V0450	CBE1V0500	/	/	IPE 360	CBE1F0265	GBA1ES010
	6									Z	
	7	V	/	CBE1V0400	/	/	/	/	IPE 400	CBE1F0270	GBA1ES010
	7									Z1	
	1000	2	U	CBE1U0350	CBE1U0400	CBE1U0450	CBE1U0500	CBE1U0550	/	IPE 300	CBE1D0220
3		CBE1D0230									
4		V	/	CBE1V0400	CBE1V0450	CBE1V0500	CBE1V0550	CBE1V0600	IPE 360	CBE1E0240	GBA1ES010
5										CBE1E0250	
6										Z1	
1600	6	/	/	/	/	/	/	/	IPE 450	CBE1F0290	GBA1ES010
2000	2	V	/	CBE1V0400	CBE1V0450	CBE1V0500	CBE1V0550	CBE1V0600	IPE 360	CBE1E0220	GBA1ES010
	3									CBE1E0230	
	4	Z2	/	CBE1Z0400	CBE1Z0450	CBE1Z0500	CBE1Z0550	CBE1Z0600	IPE 400	CBE1F0240	
	5	/	/	/	/	/	/	/	IPE 450	CBE1F0250	

*E31012002 Switch | **E240M25L0 Cable gland

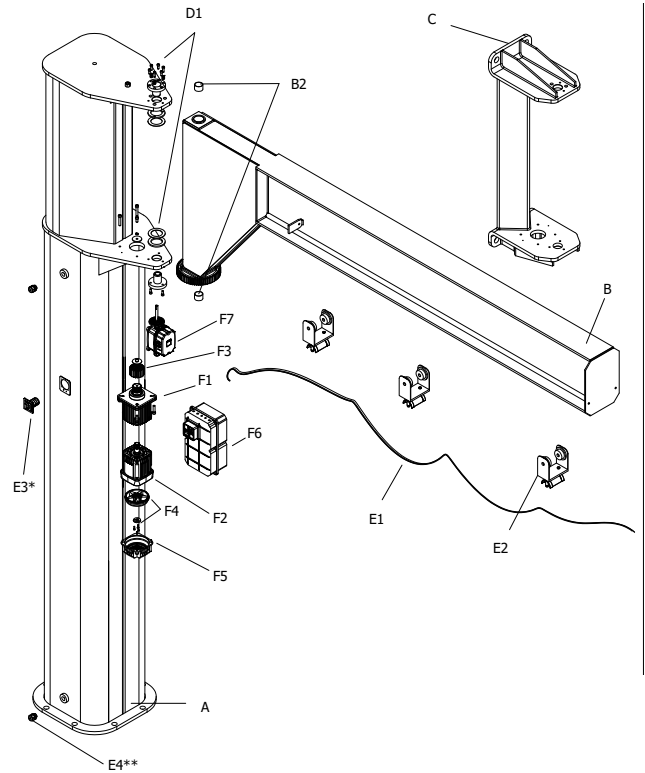

(C) BRACKET		(D) COMPLETION KIT	(E) POWER SUPPLY for column-mounted cranes without main on/off switch, see wall crane system					(F) MOTOR REDUCER UNIT CBE1F0020 (single phase) / CBE1F0050 (three phase)																																																																																																																																																																																											
TYPE	CODE	CODE	COLUMN	WALL	E1	Mt	E2	Qty.	F1	F2	F3	F4	F5	F6	F7																																																																																																																																																																																				
C/D	MBE1D0030	CBE1D0210	CBE1D0T40	MBE1D0T40	E0801215P		E46000013	3	CBE1F0011	M30AT80002 (Three phase) M30DT80000 (Single phase)	CBE5F0070	M2001S020	M2001S010	CBE1E0030 (Three phase) CBE1F0030 (Single phase)	E6000GF4C																																																																																																																																																																																				
			CBE1D0T50	MBE1D0T50				4								E/F	MBE1F0030	CBE1F0210	CBE1D0T65	MBE1D0T65			E46000019	4								/	/	CBE1D0T65	/			4									E/F	MBE1F0030	CBE1D0T75	MBE1D0T75				5									/	/		CBE1D0T75	/				5								C/D	MBE1D0030	CBE1D0210	CBE1D0T20	MBE1D0T20			E46000013	4								CBE1D0T30	MBE1D0T30			5								E/F	MBE1F0030	CBE1F0210	CBE1D0T45	MBE1D0T45			E46000019	6								CBE1D0T55	MBE1D0T55			8							CBE1D0T65	MBE1D0T65			9							E/F	MBE1F0030	CBE1F0210	/	MBE1D0T65				9							E/F	MBE1F0030	CBE1F0210	CBE1D0T25	MBE1D0T25			E46000019	4								CBE1D0T35	MBE1D0T35			5							CBE1D0T45	MBE1D0T45			6				
E/F	MBE1F0030	CBE1F0210	CBE1D0T65	MBE1D0T65			E46000019	4																																																																																																																																																																																											
/	/		CBE1D0T65	/				4																																																																																																																																																																																											
E/F	MBE1F0030		CBE1D0T75	MBE1D0T75				5																																																																																																																																																																																											
/	/		CBE1D0T75	/				5																																																																																																																																																																																											
C/D	MBE1D0030	CBE1D0210	CBE1D0T20	MBE1D0T20			E46000013	4																																																																																																																																																																																											
			CBE1D0T30	MBE1D0T30				5																																																																																																																																																																																											
E/F	MBE1F0030	CBE1F0210	CBE1D0T45	MBE1D0T45			E46000019	6																																																																																																																																																																																											
			CBE1D0T55	MBE1D0T55				8																																																																																																																																																																																											
			CBE1D0T65	MBE1D0T65				9																																																																																																																																																																																											
E/F	MBE1F0030	CBE1F0210	/	MBE1D0T65				9																																																																																																																																																																																											
E/F	MBE1F0030	CBE1F0210	CBE1D0T25	MBE1D0T25			E46000019	4																																																																																																																																																																																											
			CBE1D0T35	MBE1D0T35				5																																																																																																																																																																																											
			CBE1D0T45	MBE1D0T45				6																																																																																																																																																																																											
			/	MBE1D0T55				8																																																																																																																																																																																											

8. CONTROL BOOKLET

To demonstrate the correct performance of all of the test and maintenance activities of the jib crane, as well as to keep a record of all responsibilities in terms of the performed activities, as described in this publication, **it is advisable to diligently fill in and maintain for the expected life of the hoist** (10 years) the specific control booklet as prescribed by RES 4.4.2 of Annex I to the Machinery Directive 2006/42/EC supplied, when required, as an attachment to this publication.

In addition to the activities regarding the life and the use of the jib crane (replacement of parts, overhauls, faults of a certain entity, etc.) all operations included in the maintenance plan with quarterly and annual frequency indicated in the “**Table of periodic checking and maintenance operations**”, paragraph 6.3.2 must be noted in the control booklet.

The maintenance personnel assigned by the customer are responsible for filling in all parts of this logbook reporting the results and any notes in the specific spaces.

The name of the maintenance personnel and the date of the intervention must be clearly identified.



visit donaticranes.com
and always stay up to date

KMAN55MG00 - REV01

Donati Sollevamenti S.r.l.

Via S. Quasimodo, 17
20025 Legnano (MI) - Italy
Tel +39 0331 14811
Fax +39 0331 1481880

dvo.info@donaticranes.com
www.donaticranes.com